

26CDi XTRA

WALL MOUNTED CONDENSING COMBINATION BOILER FOR
CENTRAL HEATING AND MAINS FED DOMESTIC HOT WATER

INSTALLATION AND SERVICING INSTRUCTIONS

CE - This is a Cat II_{2H 3P} appliance

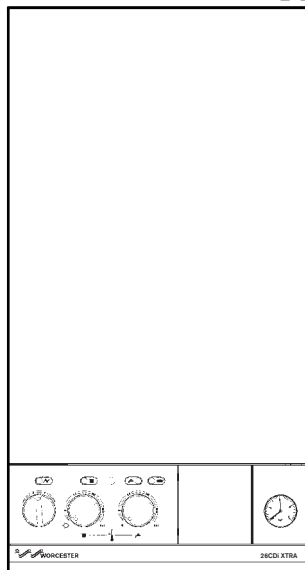

GC NUMBER 47 311 41 (N.G.)

GC NUMBER 47 311 42 (L.P.G.)



Worcester Bosch supports the
Benchmark code of practice

BOILER OUTPUT

Automatic Modulating Control

To Domestic Hot Water and Central Heating

Minimum 6.7 kW

Maximum 26.0 kW (In Condensing Mode)

THIS APPLIANCE IS FOR USE ON SEALED PRIMARY SYSTEMS ONLY

IMPORTANT: THESE INSTRUCTIONS APPLY IN GREAT BRITAIN AND IRELAND ONLY

THESE INSTRUCTIONS ARE TO BE LEFT WITH THE USER OR AT THE GAS METER

**This appliance must be installed by a competent person in accordance
with the Gas Safety (Installation and Use) Regulations 1998**

Contents

1. Installation Regulations	Page 1
2. General Information	Page 1
3. Technical Data	Page 4
4. Siting the Appliance	Page 6
5. Siting the Flue Terminal	Page 8
6. Air Supply	Page 8
7. Sealed Primary Systems	Page 9
8. Domestic Hot Water	Page 10
9. Electrical	Page 10

10. Installation	Page 14
11. Commissioning	Page 19
12. Instructions to the User	Page 22
13. Inspection and Servicing	Page 23
14. Replacement of Parts	Page 25
15. Short Parts List	Page 34
16. Operational Flow Diagrams.....	Page 36
17. Fault Finding	Page 39

1. Installation Requirements

1.1 Gas Safety (Installation and Use) Regulations 1998, as amended, all gas appliances must be installed by a competent person in accordance with the above regulations. Failure to install appliances correctly could lead to prosecution.

1.2 The manufacturer's notes must not be taken, in any way, as overriding statutory obligations.

1.3 The compliance with a British Standard does not, of itself, confer immunity from legal obligations. In particular the installation of this appliance must be in accordance with the relevant requirements of the Gas Safety (Installation and Use) Regulations 1998 as amended, current IEE Wiring Regulations BS 7671, local Building Regulations, Building Standards (Scotland) (Consolidation) and bylaws of the local Water Company. Health and Safety Document No. 635 (Electricity at Work Regulations). It should be in accordance with the relevant recommendations of the following British Standards:

- BS 6798:1987 Specification for installation of gas fired hot water boilers of rated input not exceeding 60 kW.
- BS 5449:1990 Central Heating for Domestic Premises.
- BS 5546:1990 Installation of gas hot water supplies for domestic purposes.
- BS 5440:1:1990 Flues and Ventilation for gas appliances of rated input not exceeding 60 kW: Flues.
- BS 5440:2:1989 Flues and Ventilation for gas appliances of rated input not exceeding 60 kW: Air Supply.
- BS 6891:1988 Installation of low pressure gas pipework installations up to 28mm (R1).
- BS 5482:1:1994 & 2:1997 Installation of LPG appliances.

1.4 To ensure that the installation will perform to the highest standards, the system and components should conform to any other relevant British Standards in addition to those mentioned in the instructions.

1.5 The boiler section contained within this appliance is a condensing boiler. When in use, the boiler will operate at high efficiency, emitting a white plume of condensation from the flue terminal. A condensate drain point is provided on the appliance.

1.6 The advice and instructions given in this document covers, as far as possible, the foreseeable situations which may arise. Contact Worcester Heat Systems for advice on specific installations.

2. General Information

2.1 This appliance is not suitable for external installation

2.2 The appliance controls are set to provide a maximum output of 26.0 kW in the condensing mode and 24.0 kW in the non-condensing mode for the domestic hot water and central heating load.

2.3 The control circuit provides direct burner ignition. A pilot light is not used.

2.4 PRINCIPAL APPLIANCE COMPONENTS

See fig. 1.

Fig. 1. Appliance water flow diagram.

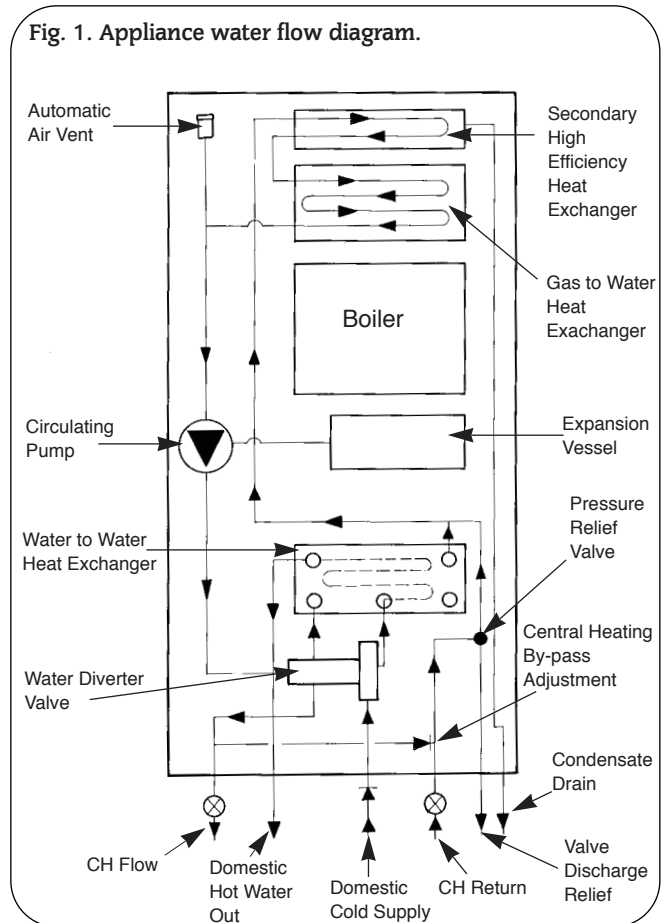

A low thermal capacity gas to water main heat exchanger connected to a secondary high efficiency heat exchanger. A water to water heat exchanger to provide domestic hot water. Fully modulating controls in the central heating and domestic hot water modes of operation.

An expansion vessel, pressure gauge and pressure relief valve.
A by-pass for the central heating system.
Temperature safety cut-out controls.
A water flow regulator.
A standard horizontal flue assembly giving flue lengths from 100mm to 1000mm.
Optional extension flue kit to provide for flue lengths of up to 2000mm.
An internal system filling loop assembly.
Optional fascia mounted electronic or mechanical programmers or a radio controlled room thermostat.
An optional wall spacing frame to allow pipe runs behind the appliance.

2.5 ELECTRICAL SUPPLY

Mains supply: 230V ~, 50 Hz., 180 watts.
External fuse: 3A.
Internal fuses: T 2A (F1), and T 1.25A (F2).

2.6 GAS SUPPLY

Check the data plate (located on the inner cover of the appliance) to ensure the appliance has been set up for the correct gas supply. The appliance can be set up for either of the following gases: Natural gas (G20) or propane (G31).

A conversion kit including instructions is available to change the appliance from one gas to the other.

The boiler requires 2.7m³/h (95.3ft³/hr) of natural (G20) or 1.03m³/hr (40ft³/hr) of propane gas (G31) The gas meter and supply pipes must be capable of supplying this quantity of gas in addition to the demands of any other appliances being served. The meter governor should deliver a dynamic pressure of 20mbar (8in wg) for natural gas or 37mbar (14.4 in wg) for propane.

The complete installation, including the gas meter, must be tested for soundness and purged. Refer to BS 6891.

2.7 CONDENSATE DRAIN

A condensate drain is provided on the appliance. This drain must be connected to a drainage point on site. All pipework and fittings in the condensate drainage system **must be made of plastic. NO OTHER MATERIALS SHALL BE USED.**

The drain outlet on the appliance is 22mm (3/4 in plastic.)

See fig. 3.

2.8 PACKING

The appliance and flue components are packed in separate cartons.

2.9 GENERAL INSTALLATION

The appliance is for connection to a sealed primary system only. The specified ventilation openings made into a wall or compartment door must not be obstructed.

If the appliance is to be fitted into a compartment then the compartment must conform to the requirements of BS 5440:2:1989.

Notwithstanding the instructions given in BS 5440:2:1989, this appliance may be fitted in a compartment with no vents as long as the minimum clearances stated in Section 6: Air Supply, are maintained.

Do not place anything on top of the appliance.

The clearances specified for servicing must be maintained. See fig. 2.

2.10 FLUE

The appliance has a multi-directional horizontal fanned flue system.

The Standard Flue assembly length is from 100mm to 1000mm. The alternative Extended Flue assembly is available, for flue lengths up to 2000mm long.

The flue system inclines 2 1/2° (44mm per metre length) towards the appliance, to prevent condensate dripping from the flue terminal.

NB: A white plume of condensate will be emitted from the flue terminal when the appliance is operating. Refer to Section 4 “Siting the appliance.”

A terminal guard, Type K2, GC 393 553, is available from Tower Flue Components, Vale Rise, Tonbridge, TN9 1TB.

Do not allow the flue terminal fitted to the outside wall to become obstructed or damaged.

A kit for internal fixing of the flue is also available, as an optional extra.

2.11 CONTROLS

The electronic control system and gas valve modulate the heat input in response to the central heating and domestic hot water temperature settings between minimum and maximum.

The ON/OFF switch will turn the mains electricity on and off to the appliance.

The Central Heating Temperature control knob provides for the selection of domestic hot water only (turned fully anti-clockwise) or central heating and domestic hot water (turned clockwise).

The position of the Domestic Hot Water control knob will determine the temperature of the water delivered to the taps.

A choice of fascia mounted programmers is available as an optional extra. A remote mounted programmer may be connected to the appliance.

The integral fascia displays indicate the status of the appliance.

There is provision for the connection of a mains voltage room thermostat and/or a frost thermostat.

The electronic controls prevent rapid cycling of the appliance in the central heating mode.

Frost Protection

The boiler is fitted with an internal frost thermostat which will protect the boiler from frost damage, as long as the mains switch on the boiler is in the on position. However, if frost protection is necessary for the system, please contact Worcester Heat Systems Technical Helpline. Tel: 0990 266241.

Thermostatic radiator valves can be used in the system.

The appliance incorporates an adjustable by-pass between the central heating flow and return.

2.12 SYSTEM NOTES

WARNING: CHECK THAT NO DIRT IS LEFT IN EITHER THE GAS OR WATER PIPEWORK AS THIS COULD CAUSE DAMAGE TO THE APPLIANCE. THOROUGHLY FLUSH THE HEATING SYSTEM, AND THE MAINS WATER SUPPLY IN ACCORDANCE WITH THE RECOMMENDATIONS OF BS 7593 :1992.

NB: AN INLET WATER FILTER IS FITTED INTO THE MAINS COLD WATER INLET ON THE APPLIANCE. CHECK THE FILTER IS FITTED WHEN THE APPLIANCE IS INSTALLED. SEE FIG. 18.

REFER TO SECTION 10 “INSTALLATION,” AND 10.2 “GENERAL FITTING.” SEE FIG. 16 .

PURGE THE GAS SUPPLY BEFORE FINALLY CONNECTING THE APPLIANCE.

The water pipe connections throughout a sealed system must be capable of sustaining a pressure of up to 3 bar.

Radiator valves must conform to the current requirements of BS 2767: 10.

The relief valve discharge must be directed away from any electrical components or where it would cause a hazard to the user.

A drain cock to BS 2879 must be fitted to the lowest point of the system.

For circuit design purposes it is important that due note is taken of the information given in Table 3 relating to the available pump head.

2.13 SHOWERS, BIDETS, TAPS AND MIXING VALVES

Hot and cold taps and mixing valves used in the system must be suitable for operating at mains pressure.

Thermostatically controlled or pressure equalising shower valves will guard against the flow of water at too high a temperature.

If using a pressure equalising valve, set the Domestic Hot Water temperature control knob to the "MAX" position.

Hot and cold mains fed water can be supplied direct to an over-rim flushing bidet subject to local water company requirements.

With all mains fed systems the flow of water from the individual taps will vary with the number of outlets operated simultaneously and the cold water mains supply pressure to the property. Flow balancing using "Ball-o-Fix" type valves is recommended to avoid an excessive reduction in flow to individual outlets. For further information contact Worcester Heat Systems Technical Helpline.

2.14 SAFETY CONSIDERATIONS

The appliance must not be operated in a waterless condition.

The appliance must not be operated with the boiler inner casing cover removed.

Work must not be carried out on the appliance without the gas and electricity supplies being turned off.

Checks must be made to ensure the ventilation openings made into walls and partitions are of the correct size and are not obstructed.

2.15 OPERATION

Hot Water Mode

With a demand for hot water the burner will light at its maximum setting and then automatically adjust its output to maintain the temperature of the delivered water. When hot water is no longer required, the burner will extinguish. The fan will continue to run for a short period to dissipate the residual heat from the appliance.

Central Heating Mode

With a demand for heating the burner will light at its minimum setting and gradually increase to give the maximum output. The output of the appliance is then automatically adjusted to maintain the temperature of the system. The output can reduce down to a minimum of 6.7 kW.

If the system no longer requires even the minimum output to maintain the desired room temperature the burner will extinguish. The fan will continue to run for a short period to dissipate the residual heat from the appliance.

The appliance will remain off for a fixed period of three minutes before re-lighting to meet the system requirements automatically.

Domestic Hot Water and Central Heating

The appliance will supply heat to the central heating system as required. A demand for hot water at a tap or shower will override the central heating requirement for the period of the hot water demand. When hot water is no longer required the appliance will return to the central heating state and its normal mode of operation.

The fan may continue to run to dissipate the residual heat from the appliance as necessary.

3. Technical Data.

The data plate is fixed to the inner casing cover. Check data plate to ensure appliance has been adjusted for supply gas.

Table 1.

Nominal Boiler ratings. (10 minutes after lighting).									
Boiler adjusted for G20 (Natural Gas).									
Mode of operation	CH Flow temp.	Output		Input. (Net)		Burner setting pressure.		Gas rate.	
		KW.	Btu/h.	KW.	Btu/h.	m bar.	in. wg	m ³ /h.	ft ³ /h.
Non-cond.	80	6.7	(22,860)	7.5	(25,590)	0.9	0.4	0.8	28.3
Condense	50	7.2	(24,566)	7.5	(25,590)	0.9	0.4	0.8	28.3
Non-cond.	80	24.0	(81,900)	25.25	(86,153)	11.7	4.7	2.7	95.6
Condense.	50	26.0	(88,710)	25.25	(86,153)	11.7	4.7	2.7	95.6
Boiler adjusted for G31 (Propane).									
Non-cond	80	6.7	(22,860)	7.5	(25,590)	2.9	7.4	0.3	10.6
Condense	50	7.2	(24,566)	7.5	(25,590)	2.9	7.4	0.3	10.6
Non-cond	80	24.0	(81,888)	25.25	(86,153)	35.5	14.0	1.03	35.4
Condense	50	26.0	(88,712)	25.25	(86,153)	35.5	14.0	1.03	35.4

G20 Net Input x 1.11 = G20 Gross Input

G31 Net Input x 1.09 = G31 Gross Input

Table 2.

Flue details.		
Horizontal flue. (N.B: Inclines 2 ¹ / ₂ ° towards the appliance.)	mm	inches
Wall hole diameter. (Diameter increases with wall thickness. See fig 17.)	120 min. to 170 max.	4.5 min. to 6.5 max.
Standard flue. Minimum length	100	4.0
Standard flue. Maximum length	1000	39.4
Extension flue. Maximum length	2000	79.0

Table 3

Available pump head.							
Mode of operation	Boiler output.		Head		Min, flow rate		Temperature rise across heating flow and return
	kW	Btu/h	Metres	Feet	L/min.	Gal/Min.	
Non-cond.	6.7	(22,860)	5.4	17.8	8.7	1.9	11°C (20°F)
Condense	7.2	(24,566)	5.7	18.8	5.1	1.1	20°C (37°F)
Non-cond.	24.0	(81,888)	2.0	6.6	23.0	5.1	15°C (27°F)
Condense.	26.0	(88,712)	3.5	11.6	18.6	4.1	20°C (37°F)

Table 4

Specifications	
Central heating flow fitting.	22mm Compression
Central heating return fitting.	22mm Compression
Cold water mains inlet fitting.	15mm Compression
Domestic hot water outlet fitting.	15mm Copper
Condensate drain connection.	22mm (¾ in Plastic)
Gas inlet fitting.	Rc ¾
Pressure relief valve discharge fitting.	15mm Copper
Overall height (including flue turret).	1000mm (39.4 inches)
Casing height.	850mm (33.5 inches)
Casing width.	450mm (17.7 inches)
Casing depth.	360mm (14.2 inches)
Weight (including water).	50 kg
Installation weight.	47 kg
Pakaged weight.	53 kg
Primary water capacity.	2.0 litres (0.45 galls)
Maximum cold supply pressure.	10 Bar (150 psi)
Minimum cold supply pressure (working) for max. hot water flow.	1.2 bar
Minimum cold supply pressure (working) to operate appliance.	0.7 bar
Maximum central heating flow temperature.	Nominally 82°C (180°F)
Output to domestic hot water	Modulating 6.7 to 24.0 kW
Output to central heating - None condensing mode.	Modulating 6.7 to 24.0 kW
Output to central heating - Condensing mode.	Modulating 7.2 to 26.0 kW
Maximum domestic hot water flow rate (from the appliance).	Nominally 8.0 litres/min
Equivalent domestic hot water flow rate to give a temperature rise of 30°C (specific rate).	Nominally 11.5 litres/min
Equivalent domestic hot water flow rate to give a temperature rise of 35°C.	Nominally 9.8 litres/min
NOX Classification	Class 3
Appliance Flue Types	C12 C32

4. Siting the Appliance

See figs. 2 and 3.

4.1 The appliance may be installed in any room although particular attention is drawn to the requirements of the current I.E.E. Wiring Regulations BS 7671 and, in Scotland, the electrical provisions of the Building Regulations applicable in Scotland, with respect to the installation of appliances in rooms containing baths or showers.

Where a room sealed appliance is installed in a room containing a bath or shower, any electrical switch or appliance control using mains electricity must not be able to be touched by a person using the bath or shower.

4.2 The appliance is not suitable for external installation.

4.3 The appliance does not require any special wall protection.

4.4 The wall must be capable of supporting the weight of the appliance. See Table 4.

4.5 The following clearances must be available for installation and for servicing: Refer to fig. 2.

4.6 The appliance can be installed in a cupboard used for airing clothes provided that the requirements of BS 6798 and BS 5440:2 are maintained.

Notwithstanding the instructions given in BS 5440:2. this appliance may be fitted in a compartment with no vents as long as the minimum clearances stated in Section 6: Air Supply, are maintained.

4.7 The airing space must be separated from the boiler space by a perforated non-combustible partition. Expanded metal or rigid wire mesh are acceptable provided that the major dimension is less than 13mm. See BS 6798:1987.

4.8 No combustible surface must be within 75mm of the casing. See BS476:4.

4.9 The distance between the inner face of a cupboard door and the cabinet front should not be less than 75mm.

4.10 Always consider the possible need to disconnect the pipes from the appliance after installation.

4.11 LPG Installation: The appliance shall not be installed in a room or internal space below ground level when it is intended for use with LPG. This does not preclude the installation into rooms which are basements with respect to one side of the building but open to ground level on the opposite side.

4.12 Because the appliance operates at high efficiency, a white plume of condensation will be emitted from the flue terminal. Care must be taken when selecting the position for the flue terminal.

Keep clear of security lighting, activated by passive infra red sensing heads.

Fig. 2. Appliance casing dimensions and required clearances.

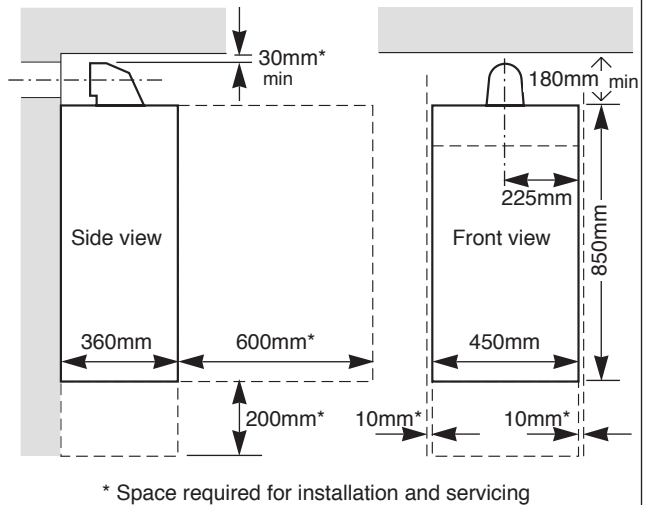

IMPORTANT:

The flue system inclines $2\frac{1}{2}^\circ$ (44mm per meter length) towards the appliance. Depending on the flue length an additional allowance must be added to the minimum clearances.

e.g. With a side flue system one meter long, measured from the side of the appliance casing, the minimum clearances required:

above the flue turret $30 + 44 = 74\text{mm}$ and
above the appliance $180 + 44 = 224\text{mm}$

	Installation	Service
Above the flue turret	30mm min.*	30mm
* An additional allowance may be required to accommodate the $2\frac{1}{2}^\circ$ flue incline when installed with a side flue. Refer to fig. 2.		
In front	600mm	600mm
Below	200mm	200mm
Right-hand side	10mm	10mm
Left-hand side	10mm	10mm

Fig. 3. Appliance pipework connections

Screw driver required to operate Valves.
Valves shown closed.

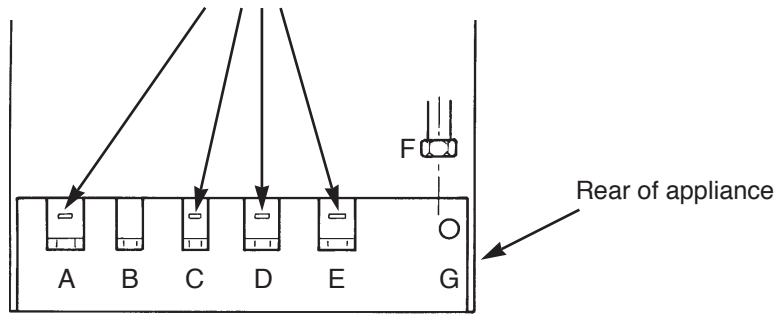

View on underside of appliance showing connections

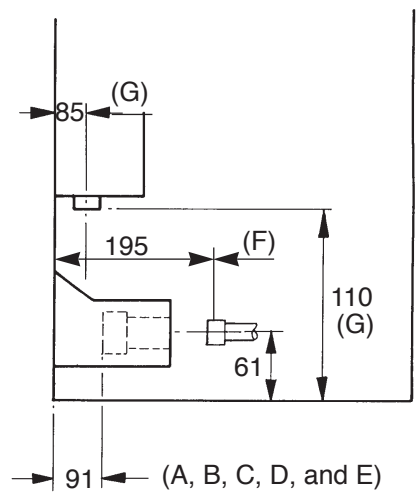
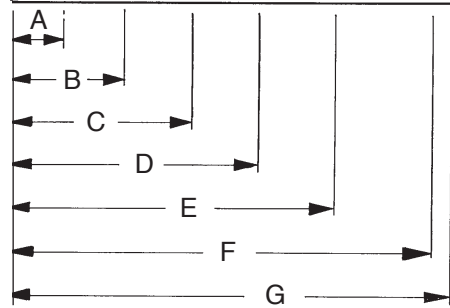
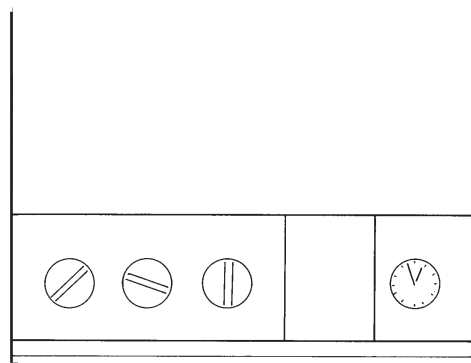

A	CH Flow	= 62.5
B	DHW Out	= 127.5
C	Mains Cold Water In	= 192.5
D	Gas Inlet	= 257.5
E	CH Return	= 322.5
F	Valve Discharge Relief	= 382.5
G	Condensate Drain	= 398

5. Siting the Flue Terminal

See fig. 4 and 15.

5.1 The flue must be installed as specified in BS 5440:Part 1.
Important. The flue must be installed with an incline of $2\frac{1}{2}^\circ$ (44mm per metre length) towards the appliance. See fig. 15.

5.2 The terminal must not cause an obstruction nor the discharge cause a nuisance.

5.3 If the terminal is fitted within 1000mm of a plastic or painted gutter or within 500mm of painted eaves then an aluminium shield at least 1000mm long should be fitted to the underside of the gutter or painted surface.

5.4 If a terminal is fitted less than 2 metres above a surface to which people have access then a guard must be fitted. See Section 2.9.

5.5 The terminal guard must be evenly spaced about the flue terminal and fixed to the wall using plated screws.

5.6 A white plume of condensation will be emitted from the flue terminal. Siting where this could cause a nuisance should be avoided. Keep clear of security lighting activated by passive infra red sensing heads.

5.7 **IMPORTANT:** It is absolutely **essential** to ensure that products of combustion discharging from the terminal cannot re-enter the building, or any other adjacent building, through ventilators, windows, doors, natural air filtration, or forced ventilation/air conditioning. If products of combustion are found to be re-entering any building, the appliance **MUST** be turned **OFF immediately**.

6. Air Supply

6.1 The appliance does not require a separate vent for combustion air.

6.2 The appliance can be fitted in a cupboard with no vents for cooling but the minimum clearances must be increased to those given below. (**Note:** The clearances at the front are for a removable panel, e.g. a door.)

Above the flue turret. (Refer to note on fig. 2.)	30mm
In front	250mm
Below	200mm
Right-hand side	75mm
Left-hand side	75mm

6.3 If the appliance is to be fitted in a cupboard or compartment with less clearance than those in the table above (minimum clearances are given in Section 4. Siting the appliance) then permanent air vents for cooling are required. One at high level and one at low level, either direct to outside air or to a room. Both vents must pass to the same room or be on the same wall to the outside air.

6.4 The minimum free areas required are given below:

Position of air vents	Air from the room	Air direct from outside
High level	270cm ²	135cm ²
Low level	270cm ²	135cm ²

6.5 Refer to BS 6798 and BS 5440:2 for additional information.

Fig. 4. Siting of the flue terminal

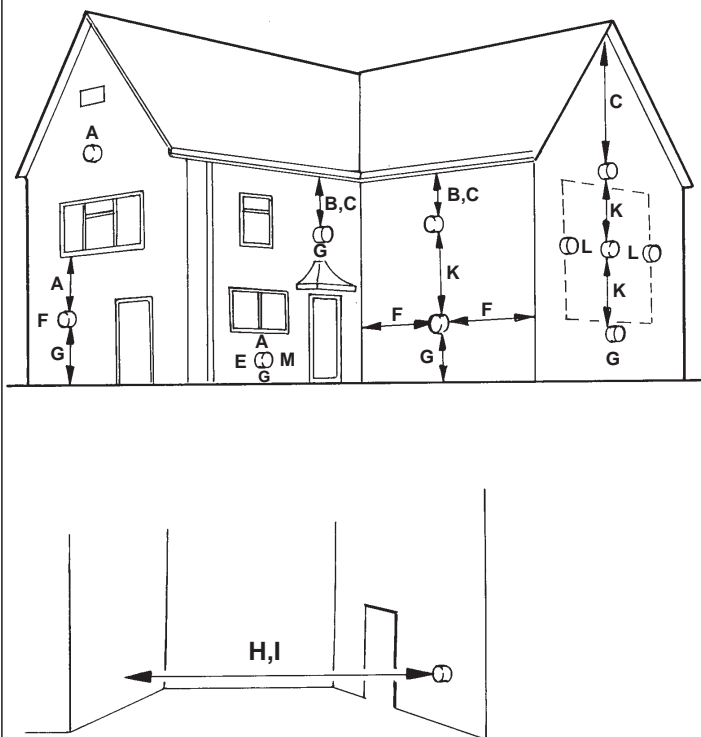

Terminal Position	Min. Distance
A - Directly below an openable window or other openings e.g. air brick	300mm (12 in)
B - Below gutters, soil pipes or drain pipes	75mm (3 in)
C - Below eaves	200mm (8 in)
- Below balconies or car port roof	Not recommended
E - From vertical drain pipes and soil pipes	75mm (3 in)
F - From internal or external corners	300mm (12 in)
G - Above ground, roof or balcony level	300mm (12 in)
H - From a surface facing a terminal	1200mm (48 in)
I - From a terminal facing a terminal	2000mm (78 in)
- From an opening in a car port (e.g. door or window) into a dwelling	Not recommended
K - Vertically from a terminal on the same wall	1500mm (59 in)
L - Horizontally from a terminal on the same wall	300mm (12 in)
M - From door, window or air vent achieve where possible	300mm (12 in)

7. Sealed Primary Systems

See figs. 5, 6, and 7.

7.1 The system must comply with the requirements of BS 6798 and BS 5449.

7.2 The appliance must not be operated without the system being full of water, properly vented and pressurised.

7.3 The pressure relief valve operates at 3 bar (45lb/in²). The discharge must be directed away from electrical components or where it might be a hazard to the user.

7.4 The pressure gauge indicates the system pressure which must be maintained.

7.5 The 8 litre expansion vessel is charged to 0.5 bar and is suitable for a static head of 5 metres (17.5ft). The pressure can be increased if the static head is greater than 5 metres (17.5ft).

7.6 With an initial system pressure of 0.5 bar, a system capacity of about 83 litres can be accommodated. Refer to BS 7074 Pt. 1 for more information. The charge pressure can be increased but with a decrease in system volume.

7.7 The appliance includes a system filling link.

7.8 Water loss must be replaced.

7.9 Filling the System. (See figs. 6 and 7.)

Remove the bottom panel to gain access to the filling loop

assembly. (The grey knob for the filling loop is packed in the hardware pack and should be fitted as shown.)

Insert the bayonet end of the filling key into the corresponding cut-outs in the filling loop housing and twist to lock the key in place.

Turn the grey knob anti-clockwise to allow water ingress and fill until the required pressure is reached.

Turn the grey knob clockwise to stop filling and remove the filling key by lining up the bayonet end of the key with the cut-outs in the filling loop housing and withdrawing the key.

N.B. The key must always be removed from the filling loop housing after the system has been filled to prevent accidental filling and to comply with Byelaw 14 of the Water Byelaws Scheme.

Store the key safely for future use.

7.10 Repeated venting loses water from the system. It is essential that this water is replaced and the system pressure maintained.

7.11 Connections to the mains water supply must not be made without the authority of the local Water Company.

7.12 The pump is set at maximum and must not be adjusted.

7.13 Connections in the system must resist a pressure of up to 3 bar.

7.14 Radiator valves must conform to BS 2767:10.

7.15 Other valves used should conform to the requirements of BS 1010.

7.16 No special system inhibitor is needed.

Fig. 5. Sealed primary water system

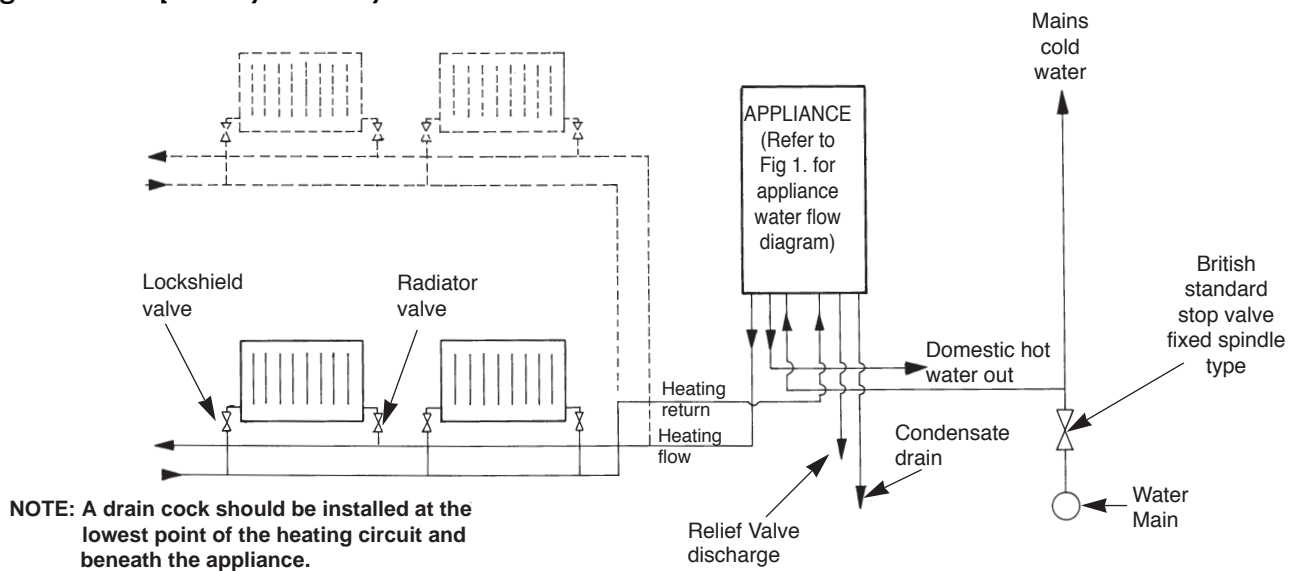

Fig. 6. Filling Loop.

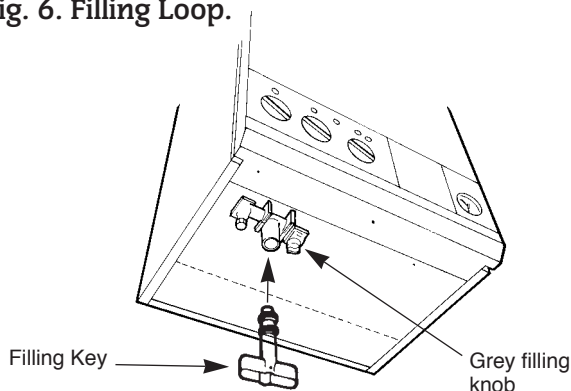
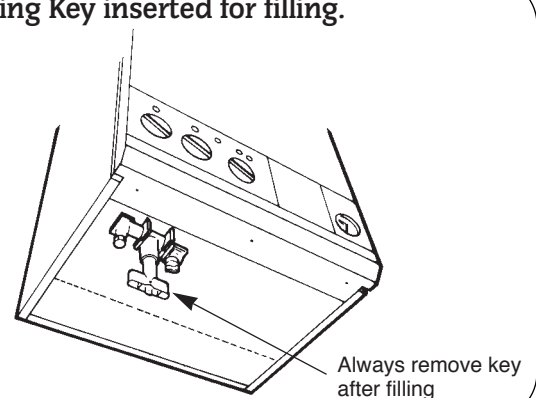

Fig. 7. Filling Key inserted for filling.



8. Domestic Hot Water

8.1 The following are general requirements and, if necessary, reference should be made to the local Water Company before fitting the appliance.

8.2 MAINS COLD WATER INLET. Devices capable of preventing the flow of expansion water must not be fitted unless separate arrangements have been made. An expansion vessel connection point is provided within the appliance.

An Rc ¹/₂ connection is provided. A Zilmet Z160 is the preferred type. A thread sealant compatible with potable water must be used.

8.3 The final 600mm of the mains cold water connection to the appliance should be made in copper tube only.

8.4 The appliance is suitable for a mains pressure of up to 10 bar (150 lb/in²).

8.5 The appliance is fitted with a mains supply isolating valve.

8.6 The maximum domestic hot water flow rate is 8.0 litres/min (± 15%) (1.8 gallons/min).

8.7 In winter (when the mains inlet water temperature is lower) a reduced flow rate at the taps may be required to achieve the type of hot water delivery temperature available in warmer weather.

8.8 It is suggested that long pipe runs to the taps or shower should be insulated to prevent the rapid cooling of domestic hot water after a tap or shower has been turned off.

8.9 Hot and cold taps and mixing valves used with this appliance must be suitable for operating at mains pressure and temperatures of 65°C.

8.10 No anti-syphonage arrangements are necessary except for some loose head showers.
See also Section 9.12 following.

8.11 Thermostatically controlled or pressure equalising shower valves will guard against the flow of water at too high a temperature.

8.12 The head of a loose head shower must not fall closer than 25 mm (1in) above the top edge of the bath to prevent its immersion in bath water. Alternatively the shower must be fitted with an anti-syphonage device at the point of the flexible hose connections.

8.13 The supply of hot and cold mains water direct to a bidet is permitted (subject to local Water Company requirements), provided that the bidet is of the over-rim flushing type. The outlet(s) should be shrouded and unable to have any temporary hand held spray attached. No anti-syphonage arrangements are necessary.

8.14 As the maximum temperature of the water to water heat exchanger is limited by the control circuit, there is normally no need for water treatment to prevent scale accumulation. In exceptional circumstances a device to prevent scale formation can be fitted.

Installation of a scale inhibitor assembly should be in accordance with the requirements of the local Water Company. An isolating valve should be fitted to allow servicing. The water hardness can be determined using a standard test paper or by reference to the local Water Company.

9. Electrical

See figs. 9, 10, 11, 12, 13, 14 and 27.

9.1 MAINS SUPPLY.

230 V ~, 50 Hz, 180 watts.

External Fuse. 3A.

Internal Fuses: T 2A (F1) and T 1.25A (F2).

Spare internal fuses are supplied at the rear of the fascia, next to the pressure gauge.

9.2 It must be possible to completely isolate the appliance.

9.3 The following connection alternatives must be used:

A 3 amp fused three-pin plug and unswitched shuttered socket outlet (both complying with the requirements of BS 1363) or a double pole isolator with a contact separation of 3mm in all poles and supplying the appliance and controls only.

9.4 The appliance must be earthed.

9.5 Mains Cable. 0.75 mm² (24 x 0.20mm) to

BS 6500 Table 16.

The mains cable must be connected into the terminal ST12, marked L (Brown or Red lead), N (Blue or Black lead) and the earth stud and be held securely in the cable clamp. For access undo the three bottom screws and remove the fascia access cover. See fig. 9.

9.6 The wiring between the appliance and the electrical supply shall comply with current IEE Wiring Regulations and any local regulations which apply.

9.7 If a room thermostat and/or external programmer is to be fitted refer to figs. 12, 13, and 14. The devices must be suitable for use with mains voltage.

9.8 Facia mounted programmers are available as optional extras. Instructions are supplied with the programmer kits.

9.9 A time switch or programmer can be fitted externally to the appliance.

9.10 The boiler is fitted with an internal frost thermostat which will protect the boiler from frost damage, as long as the mains switch on the boiler is in the on position. However, if frost protection is necessary for the system, please contact the Worcester Heat Systems Technical Helpline. Tel: 01990 266241.

9.11 SAFETY CHECK

After installation or in the event of an electrical fault the electrical system shall be checked for short circuits, fuse failure, incorrect polarity of connections, earth continuity and resistance to earth.

Fig. 9. Mains electricity connections.

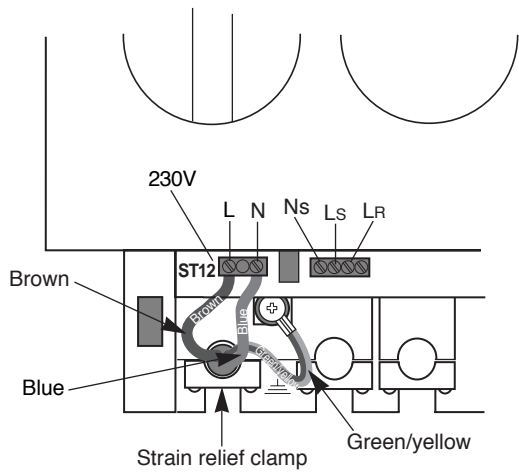

Fig. 10. Wiring diagram.

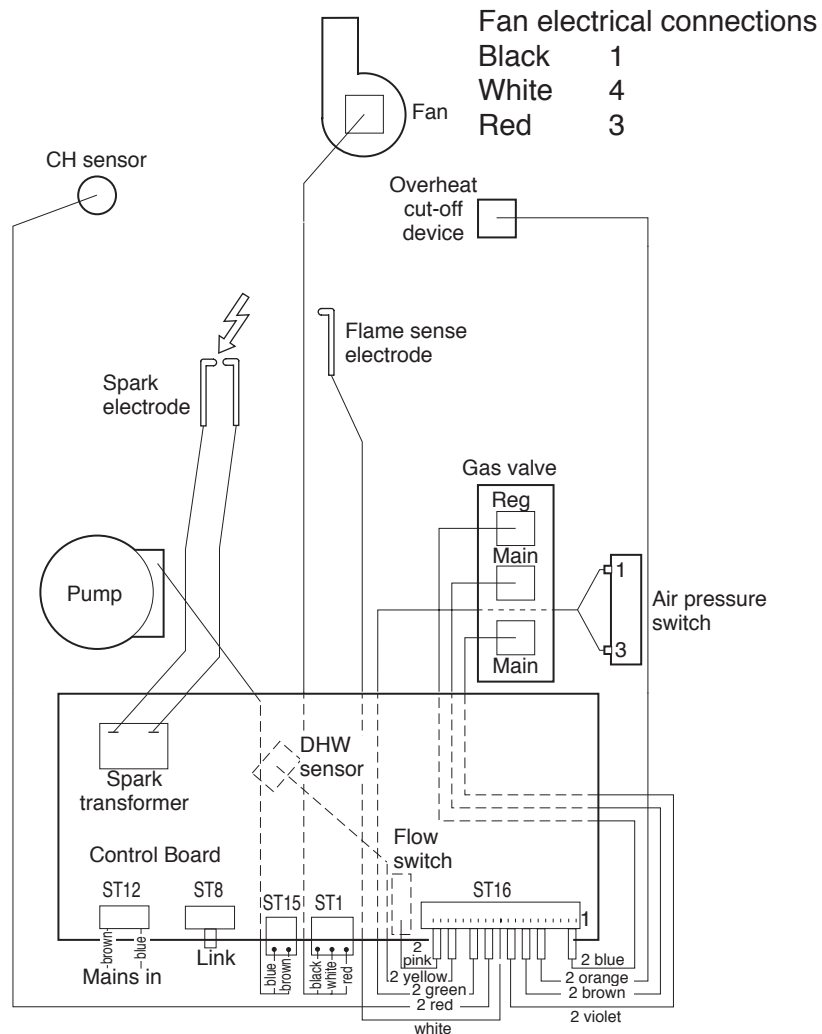

Fig. 11. Functional flow diagram.

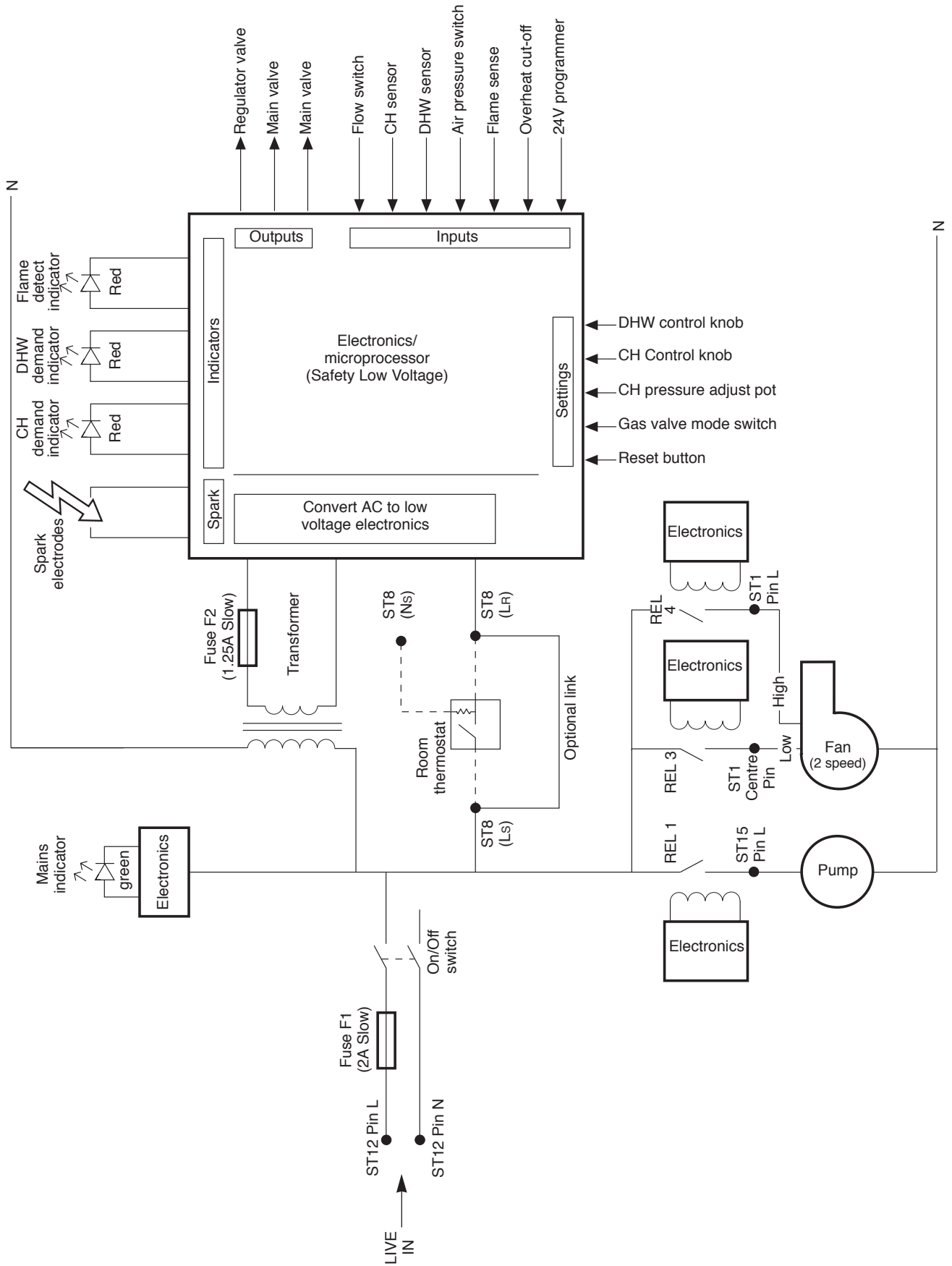

Fig. 12. 230 V room thermostat connections.

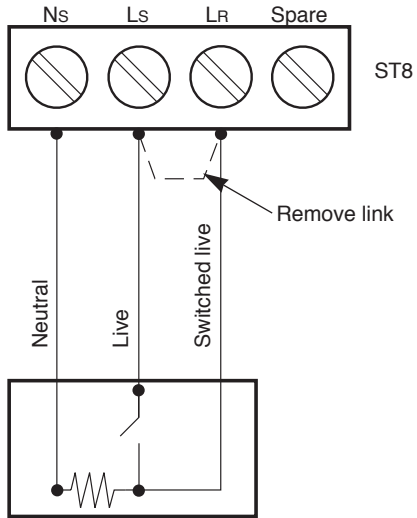

Fig. 13. 230 V programmer connections.

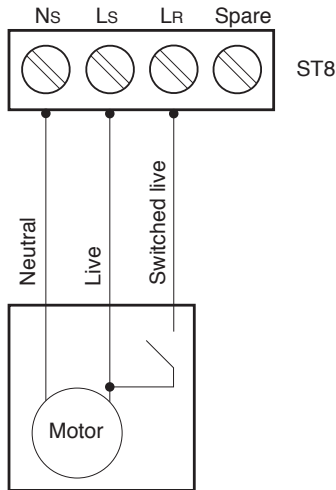
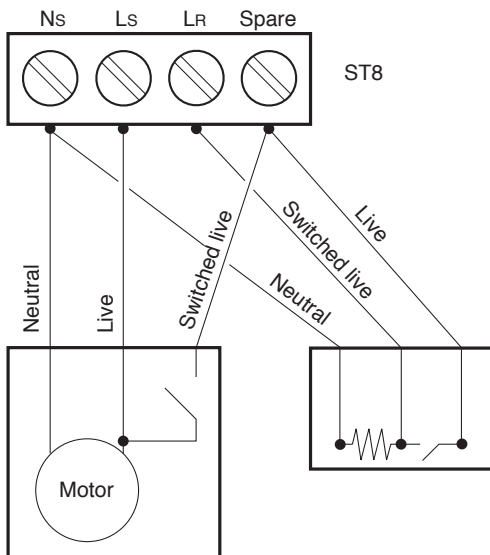

Fig. 14. 230 V room thermostat and programmer connections.



10. Installation

The appliance is supplied suitable for fitting to a sealed primary system only.

10.1 Flue Options

Refer to fig. 15.

IMPORTANT

Two flue options are available:

i) Standard Flue

To suit rear or side flue installations where the flue length measured from the appliance casing to the outside of the wall is from 100mm to 1000mm.

ii) Extended Flue

To suit rear or side flue installations where the flue length measured from the appliance casing to the outside of the wall is up to 2000mm.

Before continuing the installation it is essential to ensure the correct flue assembly is available.

Each flue assembly comprises:
Appliance casing sealing gasket.
Flue turret.

Air duct of appropriate length.
Flue terminal with flue duct, of appropriate length, attached.
Tube of silicon sealant.
Four fixing screws.
(Air duct support bracket, optional extra, part No 7 716 191 024).

Flue system notes:

i) Flue incline

The flue assembly must be installed with an incline of $2\frac{1}{2}^\circ$ (44mm per metre length). The incline must fall towards the appliance.

Refer to Section 3, Table 2 and fig. 15.

ii) Installation Standard

The flue must be installed as specified in BS 5440 Pt. 1.

10.2 General Fitting

NOTE: Read this section fully before commencing the installation.

Check the appliance carton contains:
The correct appliance.
Installer's instruction pack.
User's instruction pack.
Pre-plumbing manifold.
Wall plate cross member.
Installer's hardware pack.

Remove the packaging from the appliance leaving it to stand upright on the polystyrene plinth.

Using the two M4 thread forming screws supplied in the hardware pack assemble the wall plate cross member to the pre-plumbing manifold. See fig. 16.

Check the position chosen for the appliance is in accordance with the instructions given in Sections 4 and 5. Also refer to fig. 2.

Fig. 15. Flue Options

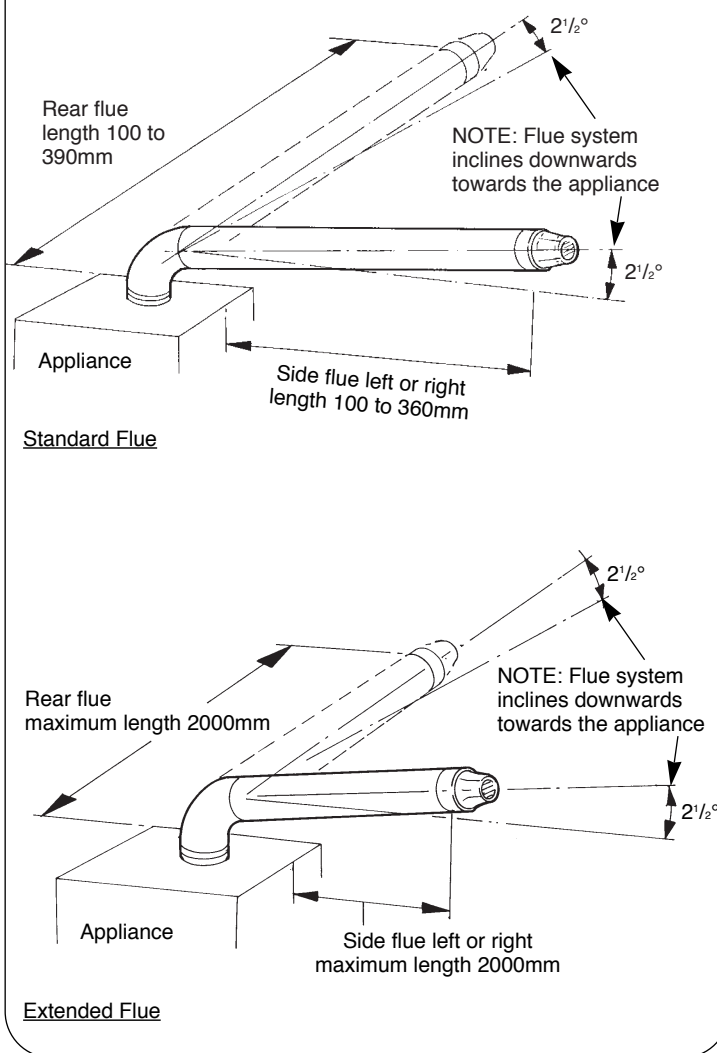

Hold the wall plate on the wall onto which the appliance is to be fitted. Check the wall plate is horizontal. See fig. 16.

Ensure the plastic cover, over the valves and 'O' rings, is left in place. The cover will protect the valves and 'O' rings against ingress of dirt and dust.

Mark the position of the fixing holes. Two at the top and four locating the pre-plumbing manifold onto the wall.

Mark the position of the appliance centre-line, from the 'V' formed by the wall plate cross member, onto the wall.

Draw a horizontal line along the top of the wall plate cross member. See fig. 16.

Rear Flue Installation

Draw the appliance vertical centre-line on the wall ensure the line passes through the 'V' previously marked.

Measure upwards, along the vertical centre-line, 800mm from the horizontal line and mark the point. This is the **rear flue centre point position** for the flue duct hole. See fig. 16.

Side Flue Installation

Extend the line from the rear flue centre point position, previously marked, along the appropriate wall.

The line must incline downwards $2\frac{1}{2}^\circ$ (44mm per metre length) towards the appliance.

Measure 197mm from the junction of the walls and mark a short vertical line. Extend horizontally the side flue line to intersect the vertical line and mark the point.

This is the **side flue centre point position** for the flue duct hole. See fig. 16.

Fig. 16. Marking the Flue Positions for all Flue Options and Fixing the Wall Mounting Plate

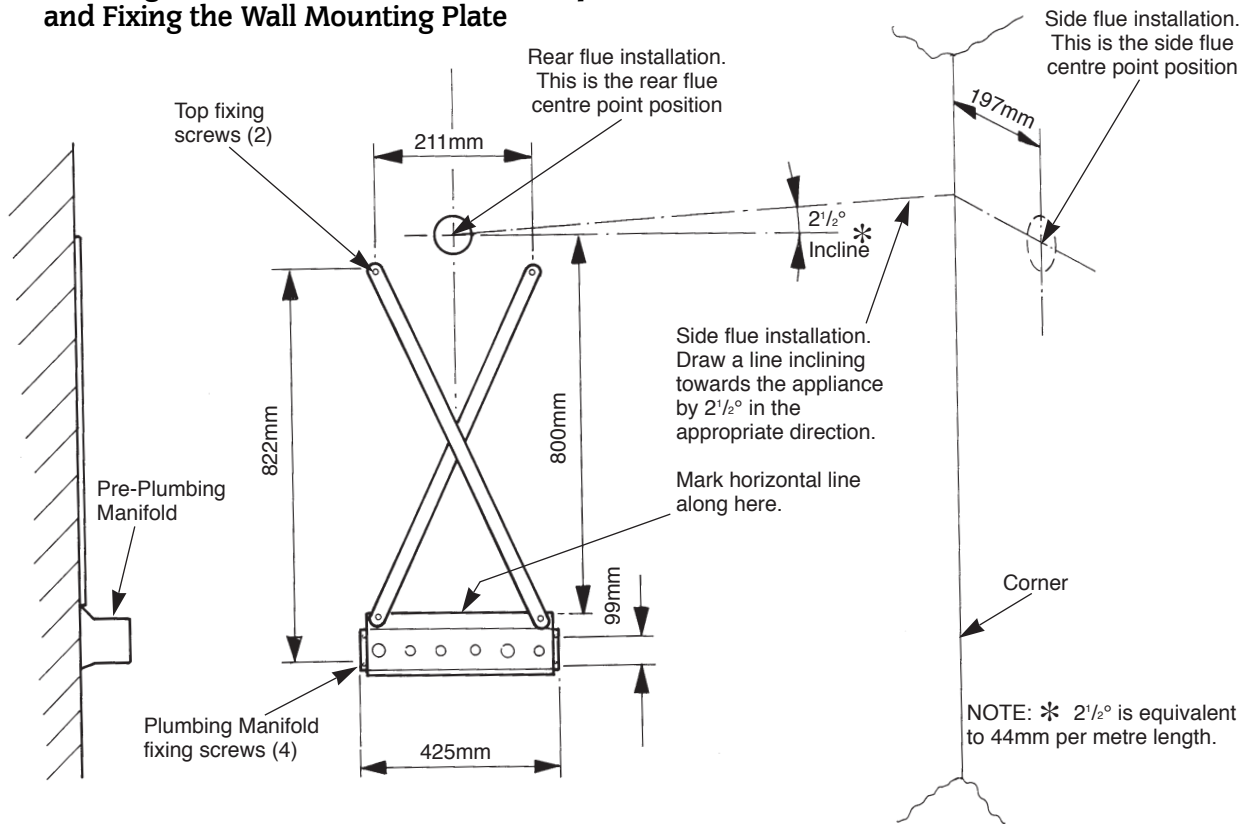
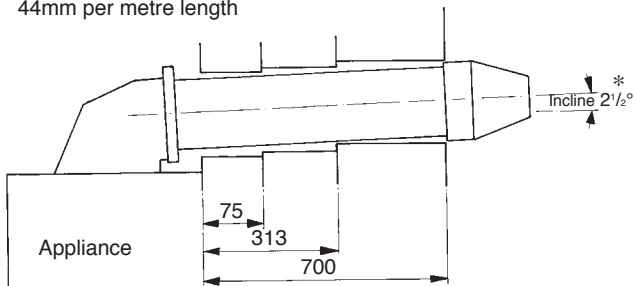

Fig. 17. Minimum Core Drill Size for Flue Duct Hole.

NOTE: *

2 1/2° is equivalent to 44mm per metre length



Wall Thickness. mm.	Flue Hole Diameter. mm.
75 Single Brick	120
313 Standard Cavity Wall	140
700 Composite Wall	170
Internal Flue Fixing Kit	150

Rear and Side Installation

Drill or cut the flue duct hole horizontally through the wall. Refer to fig.17 for the minimum core drill size for various wall thickness.

Note: The diameter of the hole takes into account the 2 1/2° incline of the flue system.

Drill the six fixing holes 6.0mm deep for No. 12 size wall plugs. Fix the wall plate to the wall, ensure it is **horizontal** before tightening the six screws.

Remove the plastic cover protecting the valve and 'O' rings. Discard the cover.

Ensure the 'O' rings are fitted and they are clean and lubricated.

Connect the gas, water, condensate and pressure relief valve connections to the manifold.

The primary system and mains supply must be thoroughly flushed and treated in accordance with the recommendations of BS 7593:1992.

Before assembling the appliance to the pre-plumbed manifold check that the inlet water filter is fitted.

The filter is fitted (push fit) into the cold water inlet on the diverter valve. See fig. 18.

Fig. 18. Fit Water Inlet Filter

IMPORTANT:

After flushing out all pipework and before mounting the appliance check that the water inlet filter is fitted.

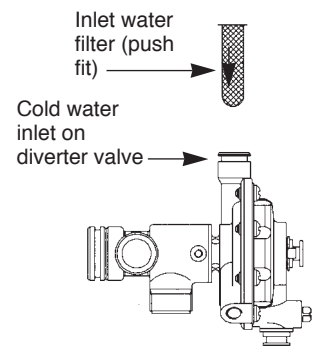

Slide the appliance onto the pre-plumbing manifold ensure the three pegs are located correctly. Secure with the two M6 nuts and washers at the top and screw the appliance to the manifold at the bottom, using the three retaining caps and M6 bolts.

See fig. 19.

To access pegs and caps remove the bottom panel.

Unscrew the automatic air vent cap. See fig. 20.

If the air and flue duct assembly is to be fitted from inside the room, the ducts must be cut to length, assembled and inserted through the wall, at this stage.

Refer to Section 10.4 Air and flue ducts preparation and assembly.

Fig. 19. Fixing the appliance to the wall mounting plate.

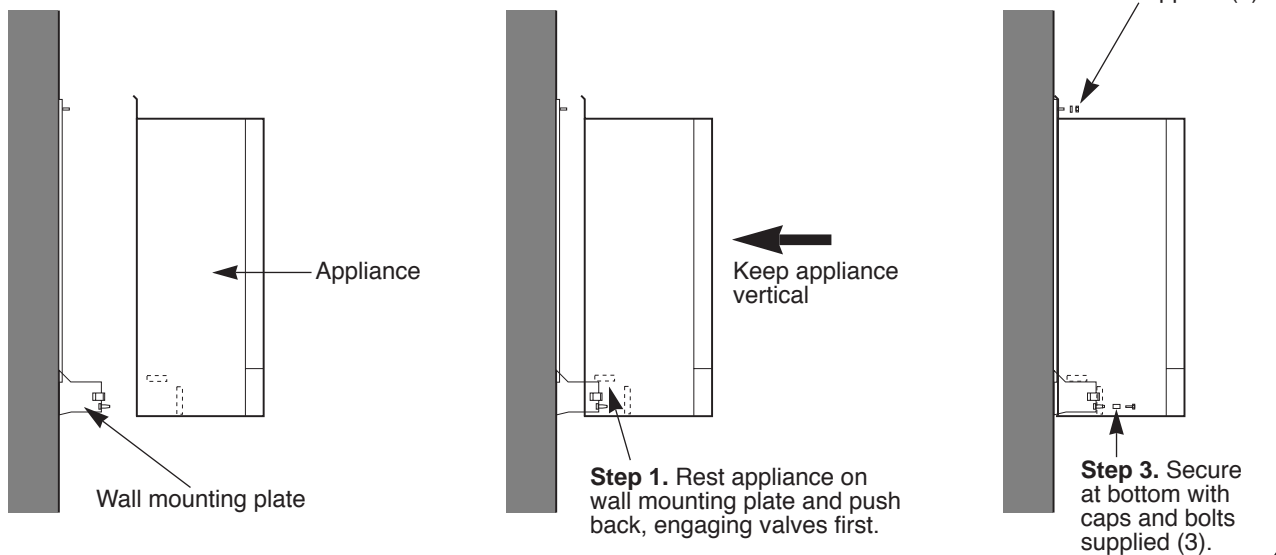
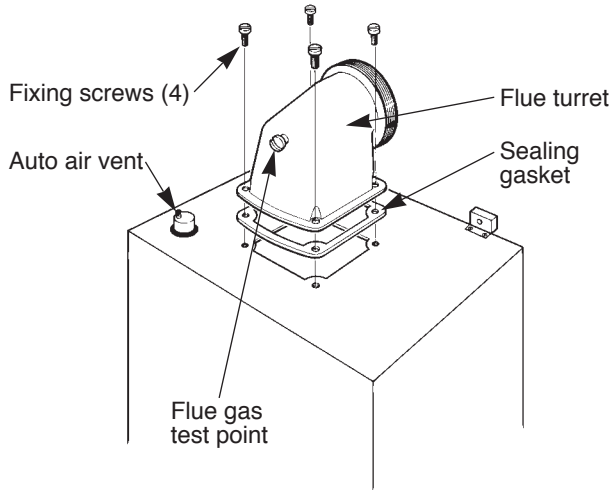

Fig. 20. Flue turret fixing and automatic air vent.



10.3 Condensate Drain Connection

The condensate drain connection is located at the bottom right hand side of the appliance.

The condensate drain pipe and collar (contained within the hardware /literature pack) is screwed to the outlet of the syphon. This pipe can be connected to either push fit 22mm plastic pipe or $\frac{3}{4}$ in solvent weld plastic pipe.

The length of condensate pipe can be reduced but care must be taken to ensure the pipe can be removed to allow removal of the syphon for cleaning and removal of appliance from the wall.

The pipe should discharge into the household drainage system and have an internal termination. If this is not practical, discharge into an outside gully or soak away is acceptable.

The condensate discharge pipe should have a fall of $2\frac{1}{2}^\circ$ (44mm per metre length). The minimum pipe diameter for internal runs is 15mm and 32mm for external runs.

Any external runs should also be insulated to prevent it from freezing.

It is not necessary to provide air breaks or traps in the discharge pipe. The appliance includes an integral 50mm trap and syphon.

The appliance is fitted with a safety device to prevent it from working if the condensate pipe gets blocked by either ice or debris.

The condensate drain pipe should be checked during any servicing and any debris found removed.

Refer to the British Gas publication "Guidance Notes for the Installation of Domestic Gas Condensing Boilers."

10.4 Air and Flue Duct Preparation and Assembly

Check the contents of the Standard Flue or the Extended Flue against their respective packing list.

Remove **all** the packing from the ducts and terminal assembly.

NOTE:

The air duct is 100mm diameter and flue duct is 60mm diameter.

WARNING: The air and flue ducts are manufactured from aluminium and must be handled with care.

Measure and cut the air and flue ducts to length ensuring that the cuts are square and free from burrs. Always check the dimensions before cutting the ducts.

The **Standard Flue** assembly, when measured from the appliance casing to the outside of the wall, accommodates a flue length of:

Rear flue - 1030mm maximum.

Side flue - 1000mm maximum.

Refer to dimension **L mm** on figs. 21 and 22.

Fig. 21. Flue Duct Length (rear flue).

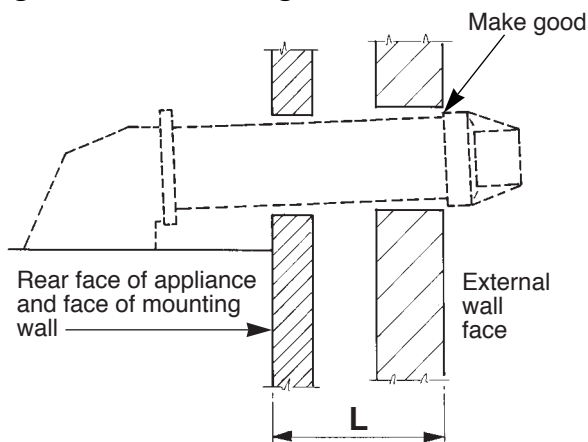
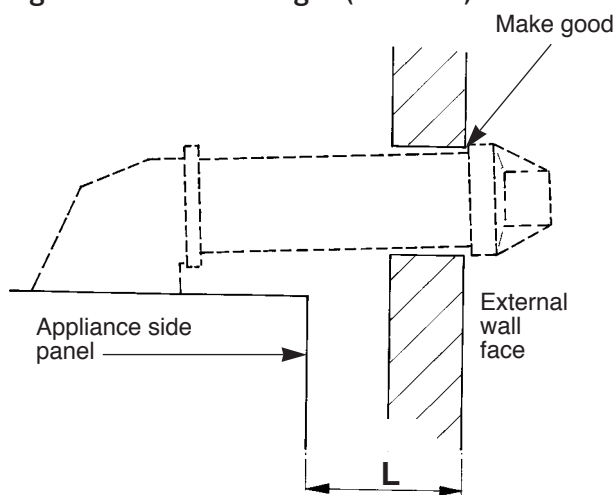

Fig. 22. Flue Duct Length (side flue).



NOTE:

i) When dimension **L** is greater than 1030mm (rear flue) or 1000mm (side flue) the Extended Flue assembly must be fitted.

ii) The Standard Flue assembly cannot be extended beyond the above maximum lengths.

When assembling air and flue ducts, ensure they are correctly located in the socket joints. Refer to figs. 23 and 24.

Take care to seal all the flue joints where indicated. To seal the flue joints, disengage the joint and apply a smear of silicone sealant around the duct. See figs. 23 and 24.

On final assembly, the air duct must be adequately supported.

Air duct support brackets are available as an optional extra.

See Section 10.1 for air duct support bracket part number.

10.5 External Fitting of the Flue Duct Assembly

Rear Flue Assembly.

a) Measure distance **L**. See fig. 23 and 24.

Air duct length = $L + 166\text{mm}$.

Flue duct length = $L + 166\text{mm}$.

b) **NB:** i) The flue duct is supplied fixed to the flue terminal. It must not be removed. The lip on the terminal marked "BOTTOM" must be at the bottom of the assembly.

ii) Do not cut the grooved end of the air duct.

c) Measure the flue duct length from the **measuring ring**, located on the flue duct, near the flue terminal. Cut the duct to size. See fig. 23.

d) Measure the air duct length from the **grooved end** of the duct. Cut the duct to size. See fig. 23.

e) Pass the air duct, grooved end first, over the flue duct and fit into the flue terminal. Ensure the air duct is fully located into the flue terminal.

f) Drill through the holes in the flue terminal into the air duct with the drill provided. Fix the flue terminal temporary with the screws provided.

NB: When assembled correctly the flue duct will extend 44mm beyond the air duct. See fig. 23.

g) Undo the screws and ease the air duct clear of the flue terminal. Apply a bead of silicone sealant, provided, around the groove in the air duct. Reassemble the air duct into the flue terminal. Fix permanently with the original screws.

h) From outside, pass the flue assembly through the wall. Locate the flue duct into the flue outlet on the turret.

i) Ease the flue duct into the turret and then ease the air duct into the turret until fully located. See fig. 24.

j) Drill through the holes in the turret into the air duct and fit temporary with the screws provided. See fig. 24.

k) Undo the screws and ease the air duct just clear of the turret. Apply a bead of silicone sealant, provided, around the air duct. Reassemble into the turret and fix with the original screws. See fig. 24.

l) Align the flue turret with the 4 holes on the appliance. Ensure the flue outlet from the fan is correctly engaged in the turret and the sealing gasket is in place. Screw the turret onto the top of the inner casing. See fig. 20.

m) Make good the internal and external brickwork or rendering.

Side Flue Assembly.

a) Measure distance **L**. See fig. 23 and 24.

Air duct length = $L + 194\text{mm}$.

Flue duct length = $L + 194\text{mm}$.

b) **NB:** i) The flue duct is supplied fixed to the flue terminal. It must not be removed. The lip on the terminal marked "BOTTOM" must be at the bottom of the assembly.

ii) Do not cut the grooved end of the air duct.

c) Measure the flue duct length from the **measuring ring**, located on the flue duct, near the flue terminal. Cut the duct to size. See fig. 23.

d) Measure the air duct length from the **grooved end** of the duct. Cut the duct to size. See fig. 23.

e) Pass the air duct, grooved end first, over the flue duct and fit into the flue terminal. Ensure the air duct is fully located into the

flue terminal.

f) Drill through the holes in the flue terminal into the air duct with the drill provided. Fix the flue terminal temporary with the screws provided.

NB: When assembled correctly the flue duct will extend 44mm beyond the air duct. See fig. 23.

g) Undo the screws and ease the air duct clear of the flue terminal. Apply a bead of silicone sealant, provided, around the groove in the air duct. Reassemble the air duct into the flue terminal. Fix permanently with the original screws.

h) From outside, pass the flue assembly through the wall. Locate the flue duct into the flue outlet on the turret.

i) Ease the flue duct into the turret and then ease the air duct into the turret until fully located. See fig. 24.

j) Drill through the holes in the turret into the air duct and fix temporary with the screws provided. See fig. 24.

k) Undo the screws and ease the air duct just clear of the turret. Apply a bead of silicone sealant, provided, around the air duct. Reassemble into the turret and fix with the original screws. See fig. 24.

l) Align the flue turret with the 4 holes on the appliance. Ensure the flue outlet from the fan is correctly engaged in the turret and the sealing gasket is in place. Screw the turret onto the top of the inner casing. See fig. 20.

m) Make good the internal and external brickwork or rendering.

10.6 Flue Kit for Internal Fitting (Optional extra)

If it is required to fit the flue system from inside the building, the hole in the wall must be 150mm (6 in.) diameter for the Standard Flue assembly.

If the Extended Flue assembly is used refer to fig. 17 for the hole in the wall diameter.

Measure and cut the ducts as previously described in Section 10.4 and 10.5.

Assemble the air and flue ducts to the flue terminal and flue turret as previously described. See Section 10.4.

Fit the rubber sealing gasket to the flue terminal. Centralise the gasket and tighten the clamping ring. See fig. 25.

Pass the assembly through the wall from inside the building so that the gasket flange is against the outside face of the wall.

See fig. 26.

Slide the flue centring ring, available from Worcester Heat Systems, onto the air duct and tighten the screw. See fig. 26.

Align the flue turret with the four holes on the appliance. Ensure the flue outlet from the fan is correctly engaged in the turret and the sealing gasket is in place. Screw the turret onto the top of the inner casing. See fig. 20.

Seal the gap around the duct with the sealant provided and make good internal brickwork.

Fig. 23. Air Duct, Flue Duct and Flue Terminal Assembly.

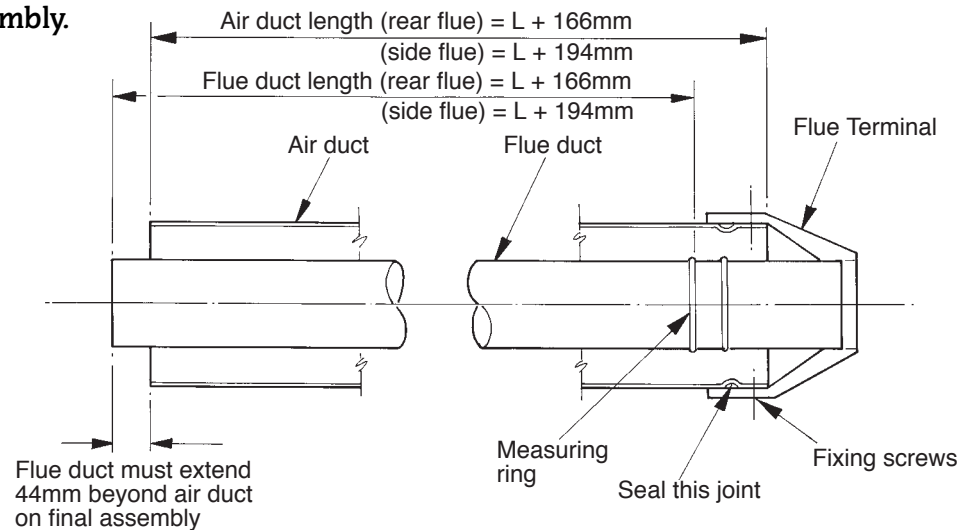

Fig. 24. Fixing the Air Duct, Flue Duct and Flue Terminal Assembly to the Flue Turret and Appliance Casing.

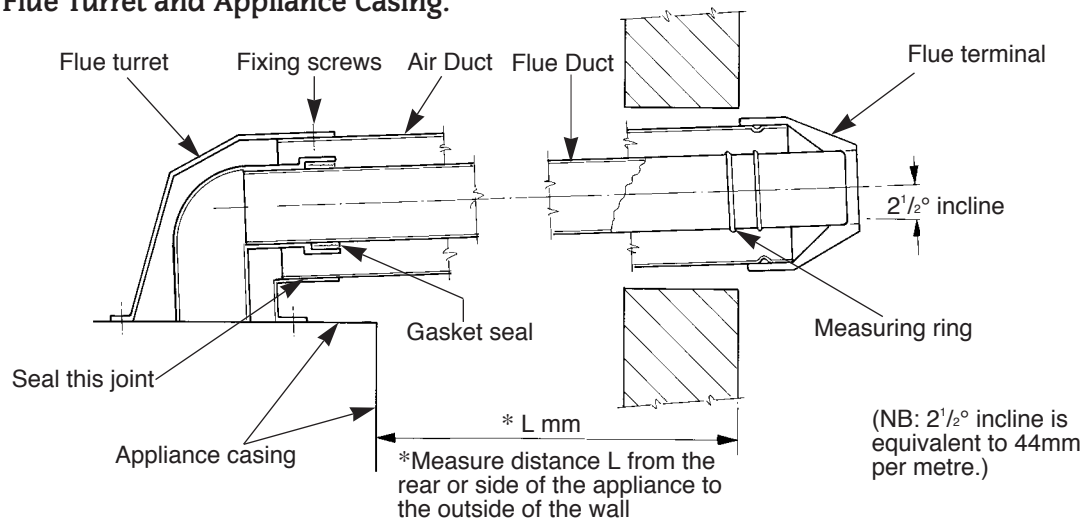

Fig. 25. Duct and Terminal Assembly for Internal Fitting of the Flue

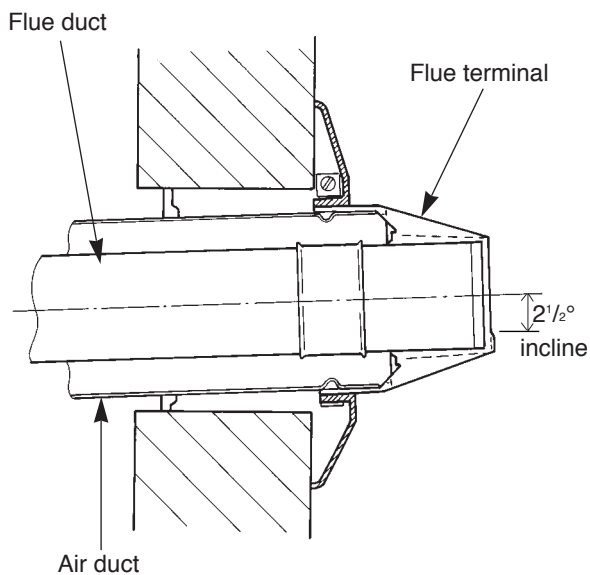
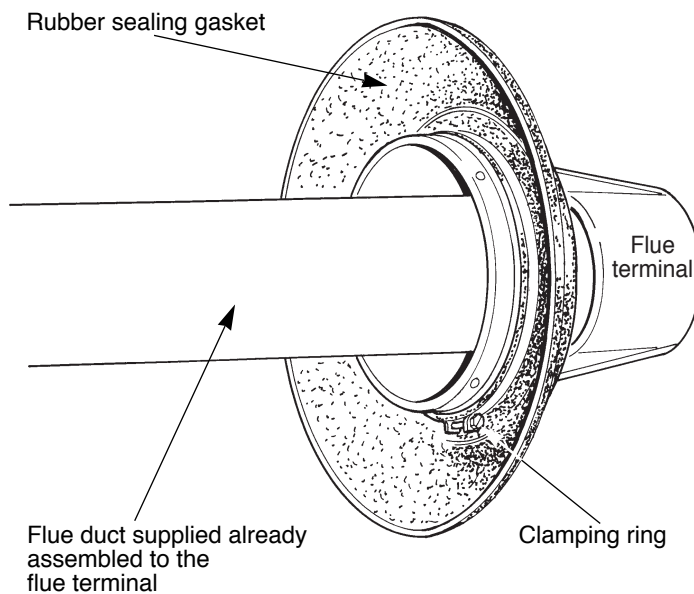

Fig. 26. Terminal Assembly for Internal Fitting of the flue



10.7 Final Installation

Check that all the water and gas connections have been tightened.

If a fascia mounted programmer is to be fitted follow the programmer instructions.

Hinge down the fascia as described in Section 13.3 (c).

Connect the mains electrical supply to the appliance at terminal ST 12 (see fig. 9). Connect any room and/or frost thermostats. The electrical leads must pass through the appropriate space in the control panel and be fixed with the cable clamps provided. See figs. 12 and 13. Refit the fascia panel.

Test the gas supply pipework up to the appliance for soundness as indicated in BS 6891.

Refer to Section 11 Commissioning for a full description of the filling, venting and the pressurising of the system.

If the appliance is not to be commissioned immediately, replace the cabinet front panel. Check that the gas supply, the electrical supply and the water connections are all turned off.

If the premises are to be left unoccupied during frosty conditions, then drain the appliance and system. For short inoperative periods, leave the appliance under the control of the built in frost thermostat or the remote frost thermostat (if fitted) or leave operating continuously with the room thermostat set at 6°C.

11. Commissioning

Summary.

The appliance is dispatched with the controls set to provide a maximum output for the domestic hot water and central heating of:

Non-condensing mode	24.0kw (81,900 Btu/h).
Condensing mode	26.0kw (88,760 But/h).

The appliance modulates automatically to satisfy lower heat loads.

Domestic Hot Water System:

Check that the mains water supply has been fully flushed out at installation.

Central Heating System:

Check that the central heating system has been fully flushed out at installation.

Gas Service:

The complete system, including the meter, must be inspected and tested for soundness and purged as indicated in BS 6891.

In the event of a leak, or suspected leak, at the 'O'ring seal on the main appliance manifold, connect a manometer to the test point on the inlet to the multifunctional gas valve. A gas leak can be traced in this section to either a visible joint the 'O'ring seal.

Fig. 27. Appliance Casing, Facia Controls and Location of Equipment.

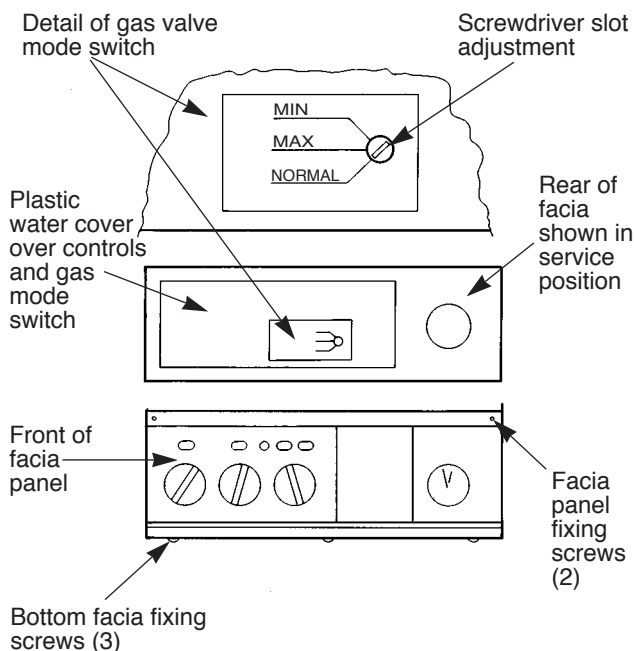
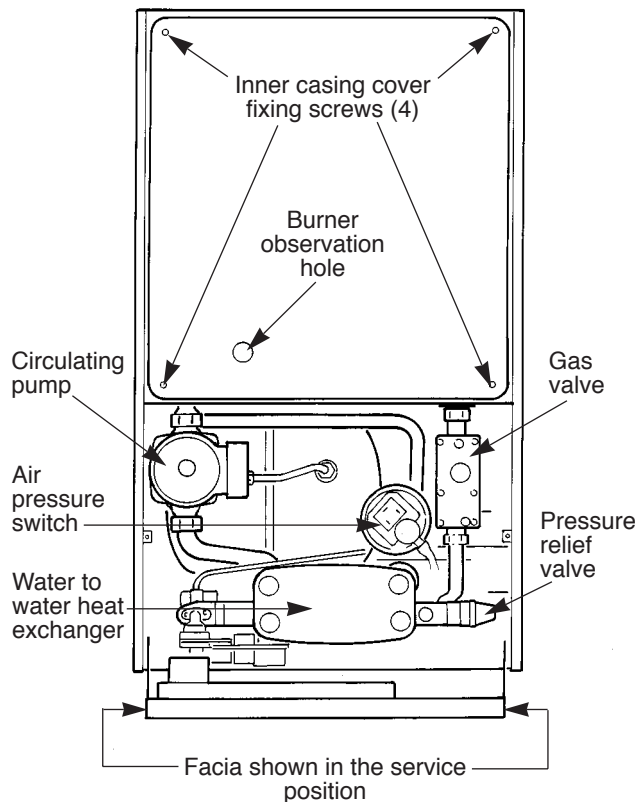

11.1. Appliance and central heating system preparation

Remove the cabinet front panel.

Check that the electrical supply and the gas service to the appliance are off. See fig 3.

Check that all the water connections throughout the system are tight.

Open the system valves at the appliance. See fig 3.

Open all the radiator valves, fill the system and vent each radiator in turn.

The automatic air vent (fixed to the flow manifold) will vent the appliance. Check that the air vent cap has been loosened.

see fig. 20.

Check that the pressure relief valve operates by turning the knob anti-clockwise until it releases. Water should be expelled from the discharge pipe. see fig. 28.

Lower the control box to gain access. Refer to Section 13.3(c).

Sealed systems only.

Set the Expansion Vessel Pressure.

The charge pressure of the expansion vessel as dispatched is 0.5 bar, which is equivalent to a static head of 5 meters (17ft). The charge pressure must not be less than the static head at the point of connection. See fig. 5. A Schraeder type valve is fitted to the expansion vessel to allow the charge pressure to be increased if necessary.

Set the System Pressure.

To fill the system, insert the bayonet end of the filling key into the corresponding cut-outs in the filling loop housing and twist to lock the key in place. See fig. 6.

Turn the system filling knob anti-clockwise to allow water ingress and fill until the pressure gauge is at 2.5 bar (37 lb/in²).

Turn the knob clockwise to stop filling and remove the filling key by lining up the bayonet end of the key with the cut-outs in the filling loop housing and withdrawing the key. (See fig. 7.)

Check for water soundness.

Release water from the system using the relief valve test knob (see fig. 28.), until the initial system design pressure is obtained, up to a maximum of 1.5 bar.

Initial system design pressure (bar) =

Expansion vessel charge pressure + 0.3 (bar).

Note:

1 bar is equivalent to 10.2 meters (33.5 ft) of water.

N.B. The key must always be removed from the filling loop housing after the system has been filled to comply with

Bylaw 14 of the Water Byelaws Scheme and to prevent accidental filling.

Store the key in a safe place for future use.

Set the movable pointer on the pressure gauge to coincide with the indicating pointer giving a permanent record of the set system pressure.

If the pressure indicated on the pressure gauge is greater than 2.6 bar when operating at the maximum central heating temperature, an extra expansion vessel must be fitted to the system as close as possible to the appliance central heating return connection.

The appliance (as despatched) can accommodate a system volume of 83 litres. Refer to BS 7074 Part 1. If the system volume is in excess of that accommodated by the expansion vessel fitted to the appliance then an extra vessel must be fitted as close as possible to the central heating return connection of the appliance.

Any extra vessel fitted must be pressurised to the same figure as the integral vessel. If the expansion vessel fails then the specified replacement must be fitted.

Fig. 28. Pressure Relief Valve.

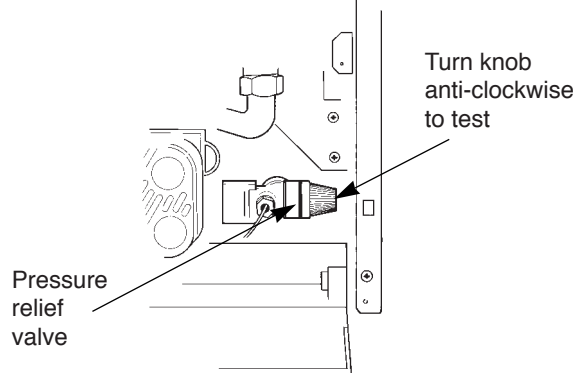

11.2 Programmer

Any programmer fitted on the appliance should be set up at this stage following the instructions sent with the programmer. The programmer will retain the setting for up to three weeks following an interruption in the electricity supply.

11.3 Appliance Operation

NOTE: Because the appliance is designed to operate at high efficiency the flue gases will be discharged at low temperature. As a result, a white plume will be emitted continuously from the flue terminal, when the appliance is operating. This condition will be more noticeable in cooler weather, even after the appliance and system have warmed up.

Turn off the gas and electricity supplies to the appliance. Loosen the burner pressure test point screw and connect a pressure gauge. See fig. 29. Access is now required to the mode switch.

Undo the two upper screws and hinge down the facia, taking care not to damage the pressure gauge capillary tube or electrical connections. See fig.27.

Setting the Burner Pressure

Check that all the radiator valves are open.

Set the room thermostat and the Central Heating Temperature Control to maximum.

Check that the sealed system is pressurised and set to the required pressure as indicated on the gauge.

Set the Operating switch (or Programmer) to **HEATING and WATER**.

Set the gas valve mode switch, located at the rear of the facia, to the maximum position. See fig. 27.

Turn on a hot water tap.

Turn on the gas and electricity supplies.

A continuous ignition spark will occur until the burner is alight and sensed by the control circuit. The burner will light and remain at its maximum domestic hot water setting.

The burner setting pressure should be 11.7 mbar for natural gas and 35.5 mbar for propane.

Set the gas valve mode switch to the normal position.

Turn both the central heating control knob and the domestic water control knob to their maximum position (i.e. fully clockwise).

Turn off the hot water tap.

The burner pressure will drop to minimum setting and will ramp up to maximum central heating setting. The burner setting pressure should be 11.7 mbar for natural gas and 35.5 mbar for propane.

Set the gas valve mode switch to the minimum position.

The burner pressure will drop to the minimum setting for both central heating mode and domestic hot water mode. The burner setting pressure should be 0.9 mbar for natural gas or 2.9 mbar for propane.

Test for gas soundness at the joint between the burner and the gas valve with leak detection fluid.

Note: The burner setting pressure is factory set and if (after checking that the supply pressure is sufficient) the correct pressure is not obtained then Worcester Heat Systems Service Department should be contacted. If the appliance does not light, check that it is not in the 'lockout' state by pressing the lockout reset button. See fig. 31.

Set the gas valve mode switch back to the normal position.

Turn off the electricity supply, and then back on again to reset the controls.

Fig. 29. Gas Valve

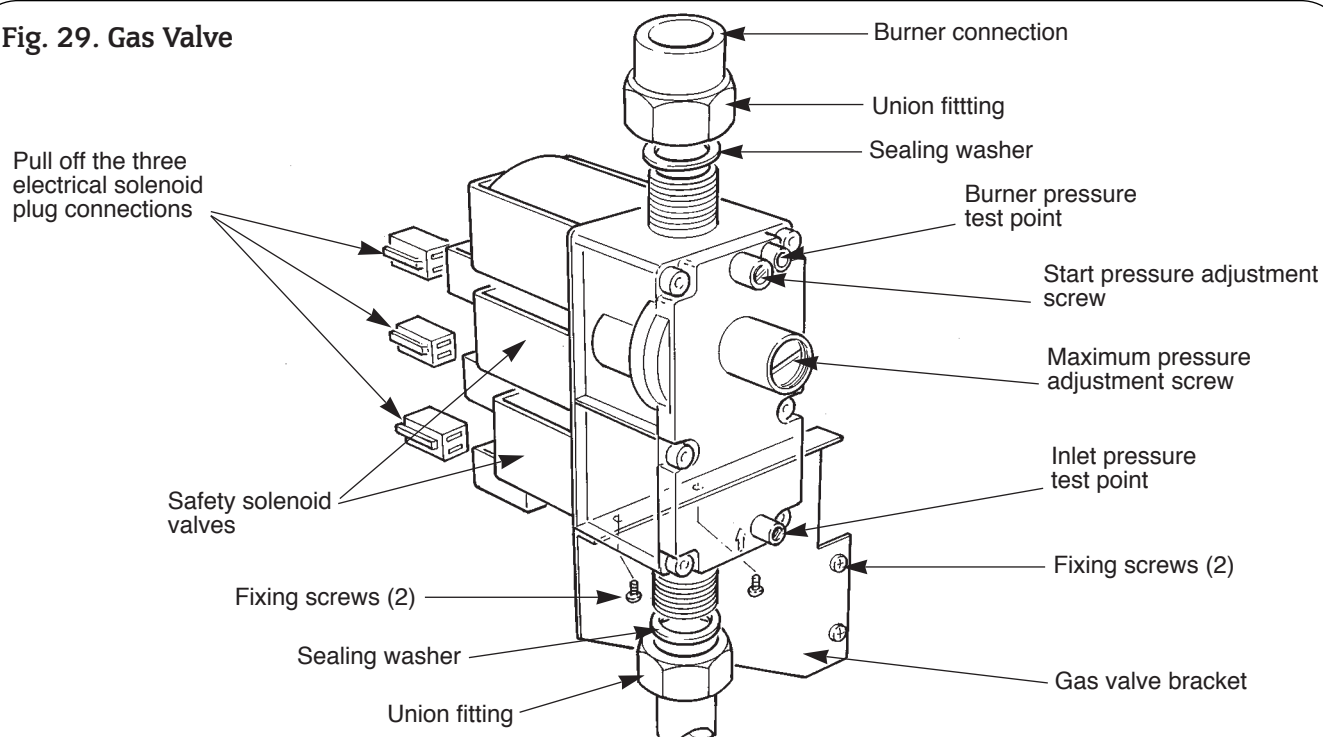

Domestic Hot Water

Commence by opening a hot tap near to the appliance. Gradually close the hot tap and check that the burner pressure drops. Fully open the tap and check that the burner pressure rises. Fully close the tap and check that the burner goes off. The fan may continue running until the appliance has cooled to a pre-set temperature.

Central Heating

Set the mode switch to the normal position.

Check that all the radiator valves are open. Set the room thermostat and the Central Heating Temperature Control to maximum.

Check that the sealed system is pressurised and set to the required pressure as indicated on the gauge.

Set the Operating Switch (and Programmer) to **HEATING and WATER**.

Turn on the gas and electricity supplies.

The burner will light.

The appliance will modulate its output between 6.7 and 26.0 kW (in condensing mode) over a period of about two minutes.

Check the system to ensure that all the radiators are heating up evenly.

Shut down all but one of the radiators and observe the burner pressure fall. Open all of the radiator valves and check that the burner pressure rises.

Balance the system so that the required temperature difference across the central heating flow and return pipes is obtained. Refer to Section 3, Table 3.

Adjust the central heating by-pass valve until the same temperature difference is obtained. See fig. 30. This should be carried out with only a single radiator operating. If thermostatic radiator valves are fitted then one radiator should be left uncontrolled.

Fig. 30. Central heating by-pass adjustment.

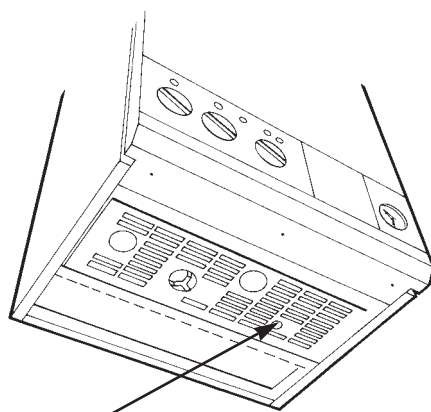

Central Heating by-pass adjustment screw

The by-pass valve should never be fully closed.

Set the room thermostat to minimum and check that the burner goes out. Reset the room thermostat to maximum and the burner will re-light and follow the normal operating procedure.

Check for proper ignition of the burner after a break in the gas supply:

Turn off the gas service cock and wait for 60 seconds. The burner will go out but sparking from the electrode will continue for 10 seconds when the appliance will enter a 'lockout' state. Carefully open the gas service cock, press the lockout reset button and observe the burner re-light and follow the normal sequence of operation.

Set the Operating Switch to **OFF**.

Turn off the gas service cock and the electrical supply to the appliance.

Drain the system while the appliance is still hot.

Refill, vent and re-pressurise the sealed system as described in Section 11.1.

Domestic Hot Water and Central Heating

Set the gas valve mode switch to the normal position.

Turn on the electricity supply to the appliance and open the gas supply cock at the appliance.

Set the Operating Switch (and Programmer) to **HEATING and WATER**. If a programmer is fitted, set the domestic hot water to Continuous or 24Hrs and the central heating to **ON**. The burner will light and heat will pass into the system. Turn on a hot water tap and check that fully heated hot water is discharged from the tap.

Close the tap and the burner will go off. The appliance will then return to the central heating mode and automatically balance with the system requirements. Set the Operating Switch to **OFF** and the burner will go out.

11.4 Condensate Check

After 30 minutes of running, turn the appliance off and remove the inner casing cover.

Check there are no condensate leaks from the fan outlet, flue turret, flue hood joints and the flue system. Ensure there are no leaks from the condensate drainage system.

11.5 Completion of Commissioning

Disconnect the pressure gauge and tighten the test point screw. Restart the appliance and check for gas soundness around the test point screw.

Refit the fascia and two fixing screws and cabinet front panel.

If the appliance is being passed over to the user immediately refer to Section 13 - 'Instructions to the User' and set the controls to the user's requirements. See fig. 31.

If the appliance is to be left inoperative, check that the Operating Switch is set to **OFF**. Turn off the gas service cock and switch off the electricity supply.

If there is any possibility of the appliance and system being left inoperative during frosty conditions, drain the appliance and system. If the premises are to be left unoccupied during frosty conditions, then drain the appliance and system.

For short inoperative periods, leave the appliance under the control of the built in frost thermostat or the remote frost thermostat (if fitted) or leave operating continuously with the room thermostat set at 6°C.

12. Instructions to the User

See fig. 31.

12.1 Tell the user how to operate the appliance and hand over the Users Instructions leaflet.

12.2 Tell the user what to do if the heating system is not to be used in frosty weather.

12.3 Tell the user the sealed system set pressure.

12.4 Tell the user of the importance of regular servicing. Worcester Heat Systems Ltd. offer a comprehensive maintenance contract.

12.5 Set the system controls to the user's requirements.

12.6 If an external programmer has been fitted which has a programmable domestic hot water facility then it is suggested that this be set to Continuous or the equivalent.

12.7 Tell the user, because the appliance is operating at high efficiency, a white plume of vapour will be emitted from the flue terminal. The plume will be more noticeable during cooler weather.

12.8 Tell the user about the safety devices and hazard notices.

Fig. 31. User controls.

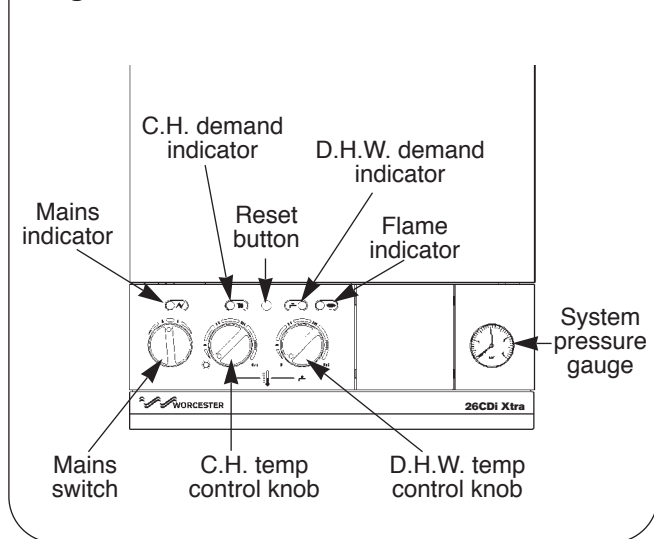

13. Inspection and Servicing

13.1 SERVICING

To ensure continued efficient operation of the appliance it must be checked and serviced as necessary at regular intervals. The frequency of servicing will depend upon the particular installation conditions and usage, but once per year should generally be adequate. The extent of the service required by the appliance is determined by the operating condition of the appliance when tested by fully qualified engineers.

Any service work must be carried out by competent engineers such as British Gas or Corgi registered personnel.

13.2 PRE-SERVICE INSPECTION

Check that the flue terminal and the terminal guard, (if fitted), are clear.

If the appliance is in a compartment, check that the ventilation openings in the compartment door or walls are clear. Refer to Section 6 - Air Supply.

Check the system and remake any joints or fittings which show signs of leakage.

Check the plastic condensate pipe for leakage and clear any debris collecting around the discharge point.

Refill, vent and re-pressurise sealed systems as described in Section 11, Commissioning.

Operate the appliance and the system taking note of any faults.

Measurement of the flue gases

For consistency of results of the flue gas measurements it is necessary to have a constant output and stationary equilibrium.

Switch on the appliance.

Switch to DHW and CH mode.

Hinge down the facia. Refer to 13.3(c).

Turn the Mode Switch to the 'Max.' position.

Wait until the appliance reaches stationary equilibrium

(approx. 10 minutes).

Remove the sealing screw on the flue turret. See fig. 20.

Insert the probe into the measurement gap up to a depth of 50mm.

Seal any gaps.

Expected measurements should be between:

CO: 0.001 and 0.005%.

CO₂: 7.0 and 8.5%.

After taking the measurement:

Replace and tighten the sealing screw.

Turn the Mode Switch back to the 'normal' position.

Put the facia back in to the correct position.

WARNING:

Disconnect the electrical supply at the mains and turn off the gas supply at the gas service cock on the appliance before servicing. After completing the service always test for gas soundness as indicated in BS 6891.

13.3 DISMANTLE THE APPLIANCE

To carry out a full and comprehensive service of the appliance remove the following parts to gain access to the components which need to be checked or serviced.

(a) Cabinet Front Panel

Remove by lifting off the supports.

(b) Inner Casing Cover

Check the electricity supply to the appliance is turned off. Remove the cabinet front panel. Unscrew the four screws securing the cover to the casing and lift off. See fig. 27.

(c) Facia Panel

Check the electricity supply to the appliance is turned off. Remove the cabinet front panel. Unscrew the two upper screws and hinge down the facia into the Service Position. Take care not to damage the pressure gauge capillary tube or electrical connections. See fig. 27.

(d) Bottom Panel

Hinge down the facia panel. Disengage the front edge of the bottom panel from the two clips and remove from the appliance. See fig. 27.

(e) Fan Assembly

Remove the inner casing cover. Carefully unplug the electrical connections and pull off the sensing tubes. Unscrew the two fixing screws locating the side of the fan assembly to the flue hood. Unscrew one fixing screw locating the fan outlet spigot to the secondary heat exchanger.

Ease the fan assembly clear of the inner casing. Ensure the sealing gasket fitted between the fan outlet spigot and secondary heat exchanger is not damaged. See fig. 32.

When refitting the fan assembly ensure the gasket seal is replaced correctly. If there is any sign of damage it must be replaced. Connect the red sensing tube to the lower position marked '+' positive and the clear tube to the top position marked '-' negative.

Connect the Black wire to terminal No. 1, Red wire to terminal No. 3 and White wire to terminal No. 4.

(f) Flue Hood Assembly

Remove the fan assembly. Undo the two screws securing the flue hood. Lift and slide the flue hood assembly forwards clear of the appliance. See fig. 32.

When refitting the hood ensure that the rear return edge passes under the lip at the rear of the combustion chamber. See fig. 32.

(g) Combustion Chamber Front and Sides Assembly

Remove the inner casing cover, fan and flue hood assembly. Slacken off to the end of the thread but do not remove the two wing nuts securing the combustion chamber.

Unhook the securing rods out of the locating holes in the combustion chamber sides.
Ease the combustion chamber front and side assembly clear of the appliance. See fig. 32. and 35.

(h) Burner Assembly

Hinge down the facia panel. Remove the inner casing cover and combustion chamber front and sides assembly. Pull off the two spark electrode leads. Disconnect the flame sensing lead at the plastic fitting under the inner casing. See fig. 32 and 36.

NOTE:

The flame sensing lead is attached to the burner. When the burner is removed ensure this lead is fed through the inner casing. Remove the grommet seal to allow the plastic connection to pass through the inner casing. Unscrew the G^{3/4} union nut on top of the gas valve and retain the sealing washer. Unscrew the front burner fixing screw. Lift the burner and ease the union nut through the inner casing sealing grommet.

Remove the burner assembly clear of the inner casing. Ensure the flame sensing lead passes through the base of the inner casing. See fig. 32 and 36.

Fig. 32. Appliance Components and Fixings (upper assembly)

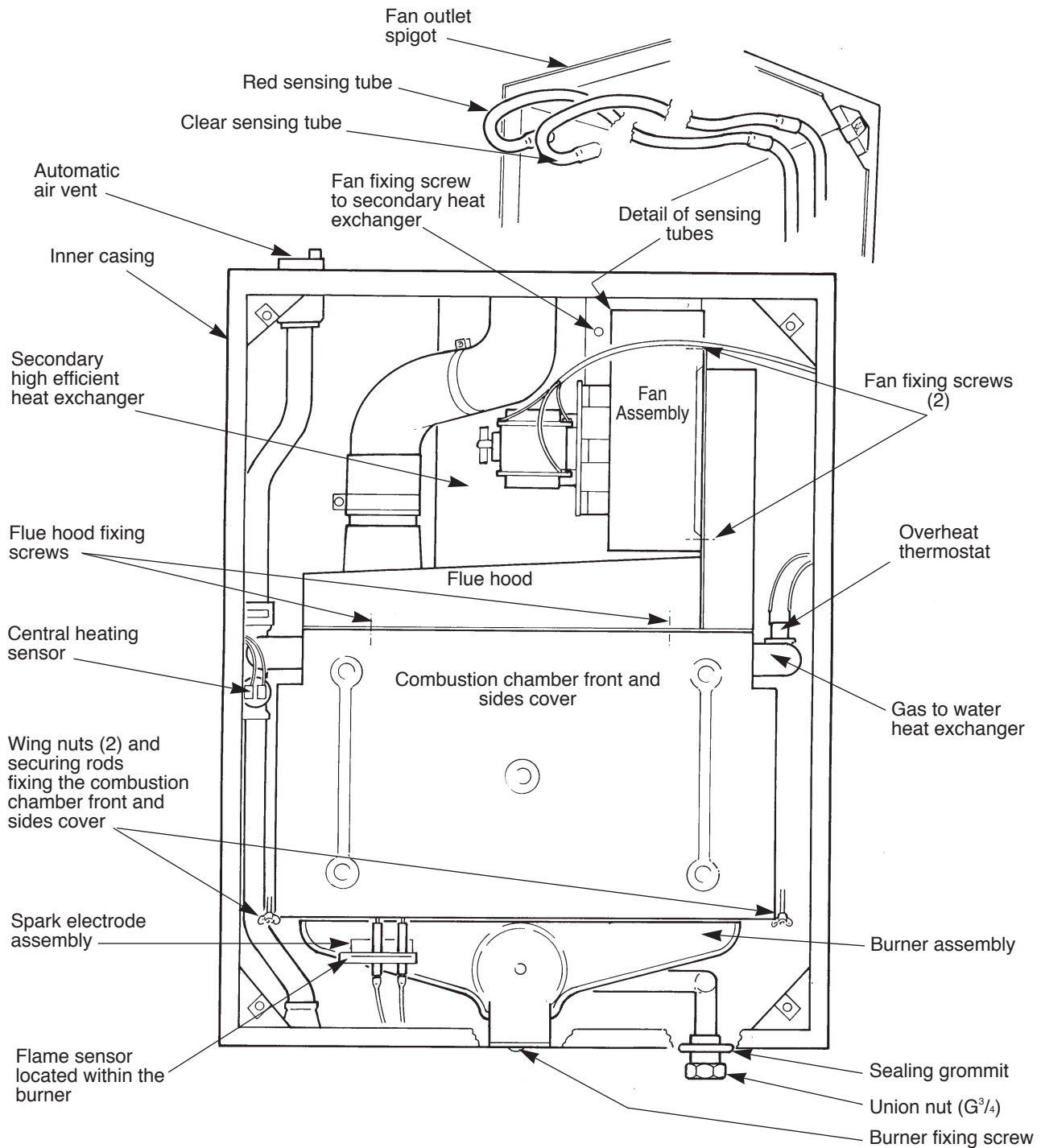

When reassembling ensure the sealing washer located in the union nut is replaced. If the washer is damaged it must be replaced.

Ensure the sealing grommets are fitted correctly and seal the inner casing.

13.4 SERVICING OF COMPONENTS

Clean the Fan

Any dust or fluff should be removed with a soft brush or by blowing. Take care not to distort the pressure sensing device.

Clean the Burner

Brush the blade tops and mixing tube with a soft brush and check that all the flame ports are clear. Remove any blockages with a non-metallic brush. Inspect the injector and clean with a soft brush. Replace the injector if it appears damaged. Do not use a wire brush or anything likely to cause damage. Replace the spark and sense electrodes if they appear damaged.

Clean the Gas to Water Heat Exchanger

Cover the burner manifold hole in the inner casing bottom panel with a cloth. Clean the heat exchanger using a soft brush. Remove the deposits from the bottom of the combustion chamber. The heat exchanger is manufactured from copper take care not to distort any of the fins.

Secondary Heat Exchanger

The secondary heat exchanger is located at the rear of the inner casing housed in a sealed stainless steel box. It is a non-serviceable component. See figs. 32 and 43.

Should a fault occur with the secondary heat exchanger requiring a replacement the heat exchanger can be removed from the inner casing and a replacement fitted.

Refer to Section 14. Replacement of parts, Item 25.

Combustion Chamber Insulation

Examine and replace any pads that are damaged. Remove any dust or deposits using a soft brush.

Re-assemble the Appliance in the Reverse Order

Check that all components are in place and correctly fixed. Leave the cabinet front panel to be fitted after checking the operation of the appliance.

Condensate Syphon

The condensate Syphon is located under the inner casing behind the gas valve. The syphon is manufactured from transparent material and must be visually inspected for blockage. If the syphon is blocked it must be removed for cleaning, ref. Section 14.3 (26).

13.5 TEST THE APPLIANCE

On completion of the service and re-assembly of the appliance, check for gas soundness and the correct operation of the appliance as described in Section 11 - Commissioning. Refit the cabinet front panel and reset the controls to the users requirements.

14. Replacement of Parts

WARNING:

Switch off the electricity and gas supplies before replacing any components. After the replacement of any components, check for gas soundness where relevant and carry out functional checks as described in Section 11 - Commissioning.

14.1 COMPONENT ACCESS

To replace components it is necessary to remove one or more sections of the cabinet and cover plates within the appliance as described in Section 13.3. The fascia panel will also require to be hinged down, as described in Section 13.3 (c).

IMPORTANT:

The following components are secured to the appliance with clips, wire clips, screws, union fittings or 'O' ring seals to ensure the joints are sound.

See figs. 32 and 37.

- Automatic air vent
- Gas to water heat exchanger
- Circulating pump
- Water to water heat exchanger
- Water diverting valve
- Pressure relief valve
- Pressure gauge
- Gas valve
- Expansion vessel

Comprehensive gasket / 'O' ring packs are available for the gas and water connections on the appliance.

Refer to Section 15 - Short Parts List.

When replacing these components the connections must fully entered so that the clips can pass completely into the locating groove or holes. The clips must not be forced into place.

When a component is replaced or disturbed it is recommended the 'O' ring or sealing washer is replaced.

If the original 'O' ring or sealing washer is used it must be inspected for damage and found to be in good condition.

If the gas valve is removed or replaced new sealing washers must be fitted.

The 'O' rings can be lubricated with a suitable lubricant (i.e. silicon based grease or glycerine) which is non-reactive with the ethylene - propylene nitrile 'O' rings.

14.2 DRAINING THE APPLIANCE

Check the electricity supply to the appliance is turned off. Before removing any component holding water it is important that as much water as possible is removed from the appliance.

(a) Central Heating Circuit. See figs. 3 and 37.

Turn off the central heating flow and return valves at the appliance. Fit tubes to the drain taps on the flow and return manifolds and open the drain taps about one turn, make sure that the dust cap on the auto air vent is loosened. See fig. 20. Close the drain taps when the flow has stopped. Be careful **not to over tighten** the drain taps.

Note: Some water will remain in the expansion vessel, pump, water diverting valve, water to water, gas to water and high efficient heat exchangers. Extra care must be taken when removing these components.

(b) Domestic Hot Water Circuit.

Turn off the mains cold supply valve at the appliance and open the lowest hot water tap.

Note: Some water will remain in the water to water heat exchanger and the water diverting valve. Extra care must be taken when removing these components.

14.3 COMPONENT REPLACEMENT

1. Automatic Air Vent. See figs. 32 and 33.

Remove the inner casing cover as described in Section 13.3 (b).

Drain the central heating circuit as described in Section 14.2 (a).

Remove the circlip and lift the assembly from the appliance.

Unscrew the automatic air vent from the pipe. Check the condition of the fibre washer.

Discard the automatic air vent.

Fit the replacement assembly in the reverse order.

Fit a new 'O' ring or ensure the original is in good condition.

Fit the circlip correctly. The dust cap must be loosened.

Open the valves and fill and re-pressurise the system as described in Section 11.1.

Reassemble the appliance in the reverse order.

2. Air Flow Pressure Switch. See fig.34.

Check that the electricity supply to the appliance is turned off. Remove the cabinet front panel and hinge the fascia down into the Service Position, as described in Sections 13.3 (a) and 13.3 (c).

Note the position of the tubes and electrical connections. Carefully pull off the sensing tubes and the electrical connections from the switch.

Undo the two screws located under the gas valve and remove the switch with the support bracket from the appliance. Remove the support bracket, held by two screws, from the switch. Retain the screws and bracket discard the switch.

Fit the replacement switch in the reverse order ensure the electrical connections are made to the correct terminals. Connect the red sensing tube to the position marked '+' positive and clear tube to the position marked '-' negative. Reassemble the appliance in the reverse order.

3. Fan. See fig. 32.

Check the electricity supply to the appliance is turned off. Remove the fan assembly as described in Section 13.3(e) and discard.

Fit the replacement fan in the reverse order. Refer to Section 13.3 (e) when replacing the fan, fitting the sensing tubes and making the electrical connections. Reassemble the appliance in the reverse order.

4. Overheat Thermostat. See fig. 33.

Check that the electricity supply to the appliance is turned off. Remove the inner casing cover as described in Section 13.3 (b). Carefully pull off the two wires from the thermostat head. Remove the two M3 screws fixing the thermostat to the mounting plate on the heat exchanger. Retain the screws and discard the thermostat.

Fit the replacement thermostat in the reverse order ensure some heat sink compound is between the thermostat and the mounting plate. Reassemble the appliance in the reverse order.

Fig. 33. Gas to Water Heat Exchanger and Auto Air Vent.

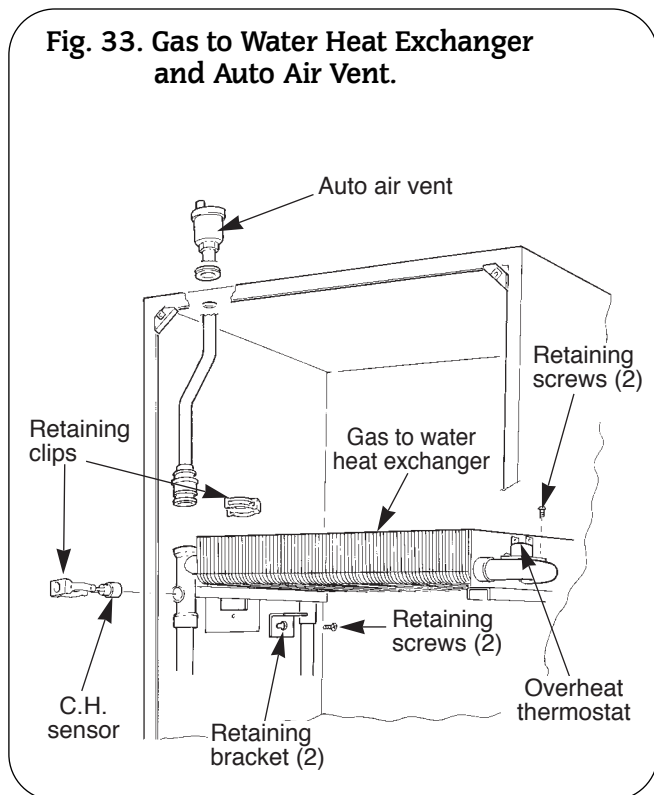

5. Gas to Water Heat Exchanger. See figs. 32 and 33.

Check that the electricity supply to the appliance is turned off. Drain the central heating circuit as described in Section 14.2 (a). Remove the inner casing cover, fan, flue hood assembly, overheat thermostat, central heating sensor and burner as described in Section 13.3 (b, e, f, g and h) and Section 14.3 (4) and (12). Slacken the two screws and remove the two side retaining brackets. Lift the heat exchanger clear of the casing. Take care the rear insulation panel does not drop forwards onto the burner.

Retain the screws and brackets discard the heat exchanger. Fit the replacement heat exchanger in the reverse order. Ensure both 'O' rings are correctly fitted and lubricated. Apply a layer of heat sink compound to each of the thermostats. Open the valves and fill and re-pressurise the system as described in Section 11.1. Reassemble the appliance in the reverse order.

Fig. 34. Air Flow Pressure.

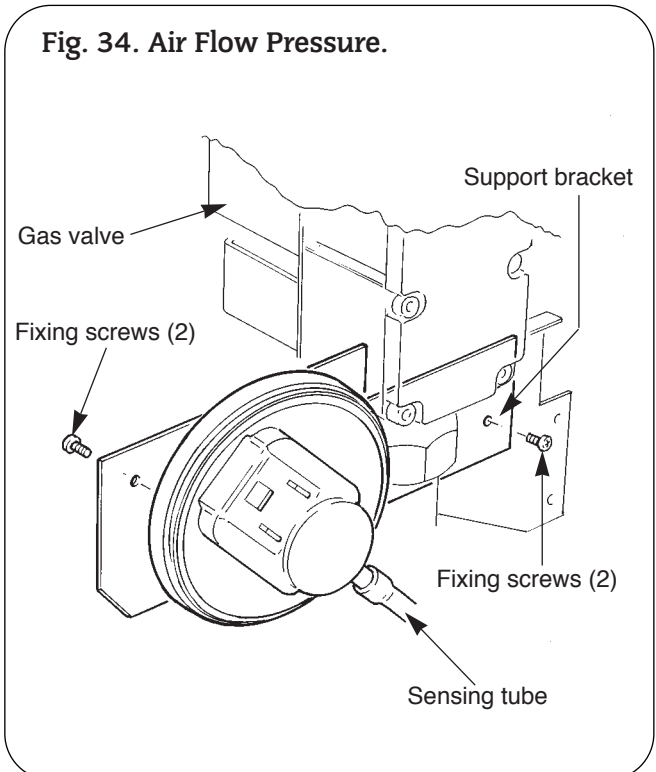

6. Combustion Chamber Insulation. See figs. 32 and 35.

Check that the electricity supply to the appliance is turned off. Drain the central heating circuit as described in Section 14.2 (a). Remove the inner casing cover, fan assembly, flue hood assembly, combustion chamber front and sides assembly and gas to water heat exchanger as described in Sections 13.3 (b, e, f and g), and 14.3 (5).

Remove the fibre insulation pads from the combustion chamber sides, rear, and front sections. To avoid the risk of fine particulates dampen the pads before removal.

Discard the insulation pads. Fit the replacement pads in the reverse order. Take care not to damage the pads

Reassemble the appliance in the reverse order. Open the valves and fill and re-pressurise the system as described in Section 11.1.

7. Burner. See figs. 32 and 36.

Check that the electricity and gas supplies to the appliance are turned off. Remove the burner assembly as described in Section 13.3 (h) and discard.

Fit the replacement burner and reassemble in the reverse order taking care not to damage the electrode leads.

When reassembling the appliance follow the description in Section 13.3 (h).

Fig. 35. Combustion Chamber Insulation

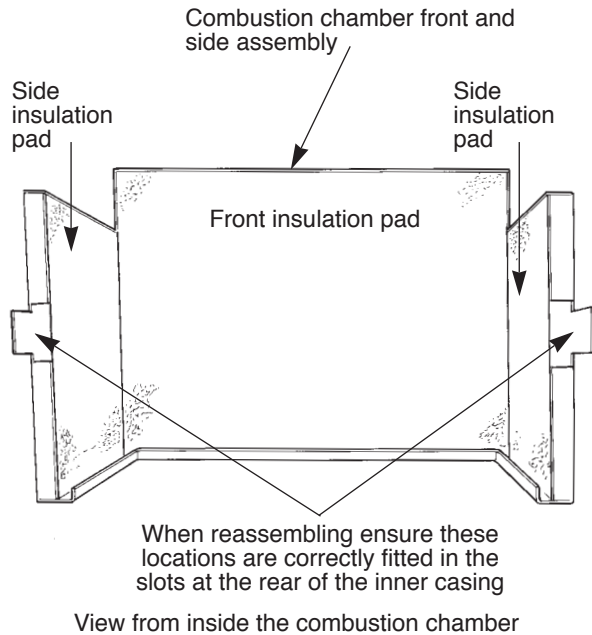

8. Burner Injector. See fig. 36.
Remove the burner as described in Section 13.3 (h).
Unscrew the brass injector from the burner and discard.
Fit the replacement injector and reassemble in the reverse order.
Fit the burner with the replacement injector in the reverse order take care not to damage the electrode leads. When reassembling the appliance follow the description in Section 13.3 (h).

Fig. 36. Burner and Electrode

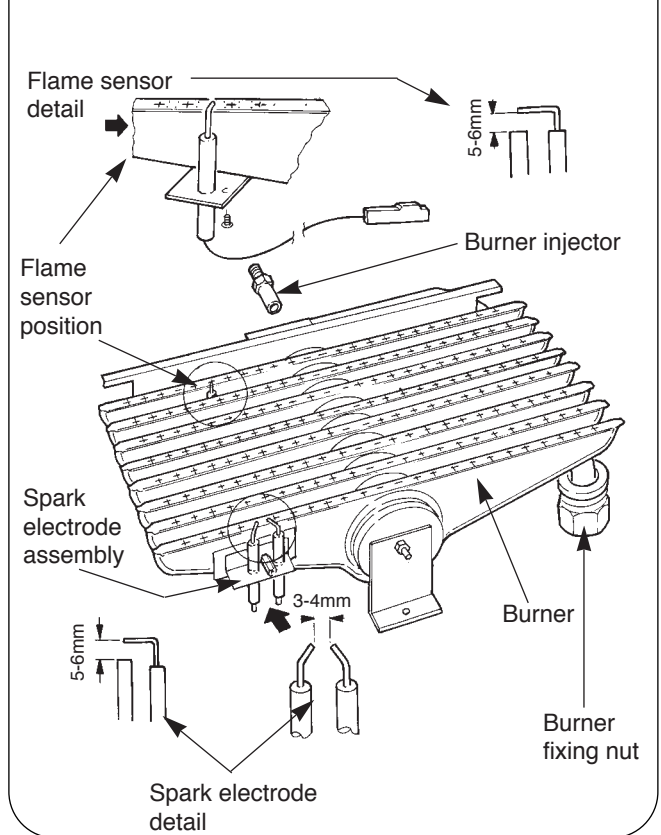

9. Spark Electrode Assembly. See figs. 32 and 36.
Remove the combustion chamber front and sides as described in 13.3 (g)

Carefully pull off the two electrode leads.
Unscrew the M4 extended nut and remove the spark electrode assembly from the burner and discard.
Fit the replacement electrode in the reverse order, check the spark gap is 3 to 4mm.
Reassemble the appliance in the reverse order.

10. Flame Sensor. See figs. 32 and 36.
Remove the burner as described in Section 13.3 (h).
Undo the M3 screw and remove the sense electrode from the burner.
Discard the electrode, retain the screw.
Fit the replacement electrode in the reverse order, checking that the sense gap is 5 to 6mm.
Reassemble the appliance in the reverse order

11. Gas Valve. See figs. 27, 29, 32 and 37.
Check that the electricity and gas supplies to the appliance are turned off.
Hinge down the fascia panel into the Servicing Position as described in Section 13.3 (c).
Remove the air pressure switch bracket as described in Section 14.3 (2). Ease the assembly clear of the gas valve.
Unscrew the two G³/₄ inch union nuts on the gas valve. Remove the two screws on the RHS securing gas valve bracket to the appliance.
Remove the gas valve from the appliance.
Support the valve and carefully pull off the three electrical solenoid plug connections. See fig. 29.
Discard the gas valve retain the screws.
Fit the replacement gas valve in the reverse order using new sealing washers. Check the washers are correctly fitted.
Reassemble the appliance in the reverse order.
Turn on the gas supply and check for soundness.

To set the burner pressure. See fig. 29.
After a new gas valve has been fitted the burner pressures must be set.
Follow the procedure described in Section 11.3 - Appliance Operation.
Turn both the central heating control knob and the domestic water control knob to their maximum position (i.e. fully clockwise).
The maximum domestic hot water burner pressure must be set first because it affects the other pressures.
Turn the gas mode switch, located behind the fascia, to the maximum position and open a hot water tap.
Adjust the maximum pressure adjustment screw on the gas valve to give a burner pressure of 11.7 mbar for natural gas (G20).
For propane (G31) the maximum pressure adjustment screw should be fully screwed in to give a pressure of 35.5 mbar.
Close the hot water tap and turn the gas valve mode switch to the minimum position.
Adjust the start pressure adjustment screw on the gas valve to give a burner pressure of 0.9 mbar for natural gas (G20) or 2.9 mbar for propane (G31).
Turn the gas valve mode switch to the normal position.
Ensure the appliance lights in the central heating mode.
Turn the CH pressure adjuster fully clockwise, wait until the burner pressure has stopped increasing and then slowly turn the CH pressure adjuster anti clockwise until the burner pressure is 11.7 mbar for natural gas (G20) or 35.5 mbar for propane (G31). This will allow for maximum output to central heating.
Important:
Check the data plate on the appliance to establish the required output for the dwelling. Re-adjust the central heating output if necessary.
After completing the adjustments, check the pressure settings and re-adjust as necessary.
Reassemble the appliance in the reverse order.

12. Central Heating Sensor. See figs. 32 and 33.
 Check that the electricity supply to the appliance is turned off.
 Remove the inner casing cover as described in Section 13.3 (b).
 Carefully pull off the two leads from the sensor.
 Pull off the sensor and spring retaining clip from the pipe.
 Discard the sensor retain the clip.
 Fit the replacement sensor in reverse order with a layer of heat sink compound between the faces.
 Refit the leads. Polarity is not important.
 Reassemble the appliance in the reverse order.

13. Domestic Hot Water Sensor. See figs. 37 and 39.
 Check that the electricity supply to the appliance is turned off.
 Hinge the fascia panel down into the Servicing Position as described in Section 13.3 (c).
 Carefully pull off the two leads from the sensor.
 Remove the clamping screw, pull off the sensor and spring retaining clip from the pipe. Discard the sensor, retain the screw and clip.
 Fit the replacement sensor in the reverse order ensuring a layer of heat sink compound is between the faces. Refit the leads. Polarity is not important.
 Reassemble the appliance in the reverse order.

14. Circulating Pump. See figs. 37 and 38.
 Check that the electricity supply to the appliance is turned off.
 Drain the central heating circuit as described in Section 14.2 (a).
 Hinge the fascia panel down into the Servicing Position as described in Section 13.3 (c).
 Unscrew the two pump union nuts and the pipe to the expansion vessel. Ease the pump from the pipe-work. Support the pump and remove the electrical cover.
 Disconnect the electrical wires taking note of their positions. Remove the pump from the appliance.
 Unscrew the expansion vessel brass connection from the pump. Discard the pump retain the brass connection.
 Fit the brass connection to the replacement pump using sealing compound on the threads.
 Fit the replacement pump in the reverse order using new sealing washers.
 Reassemble the appliance in the reverse order.

Alternatively replace the pump head only by removing the four Allen screws on the pump, remove the head and support whilst removing the electrical connections. Discard the head. Refit the new head.
 Open the valves and fill and re-pressurise the system as described in Section 11.1.
 Note: The direction of flow should be downwards. The speed should always be set to maximum.

Fig. 37. Appliance Components (lower assembly)

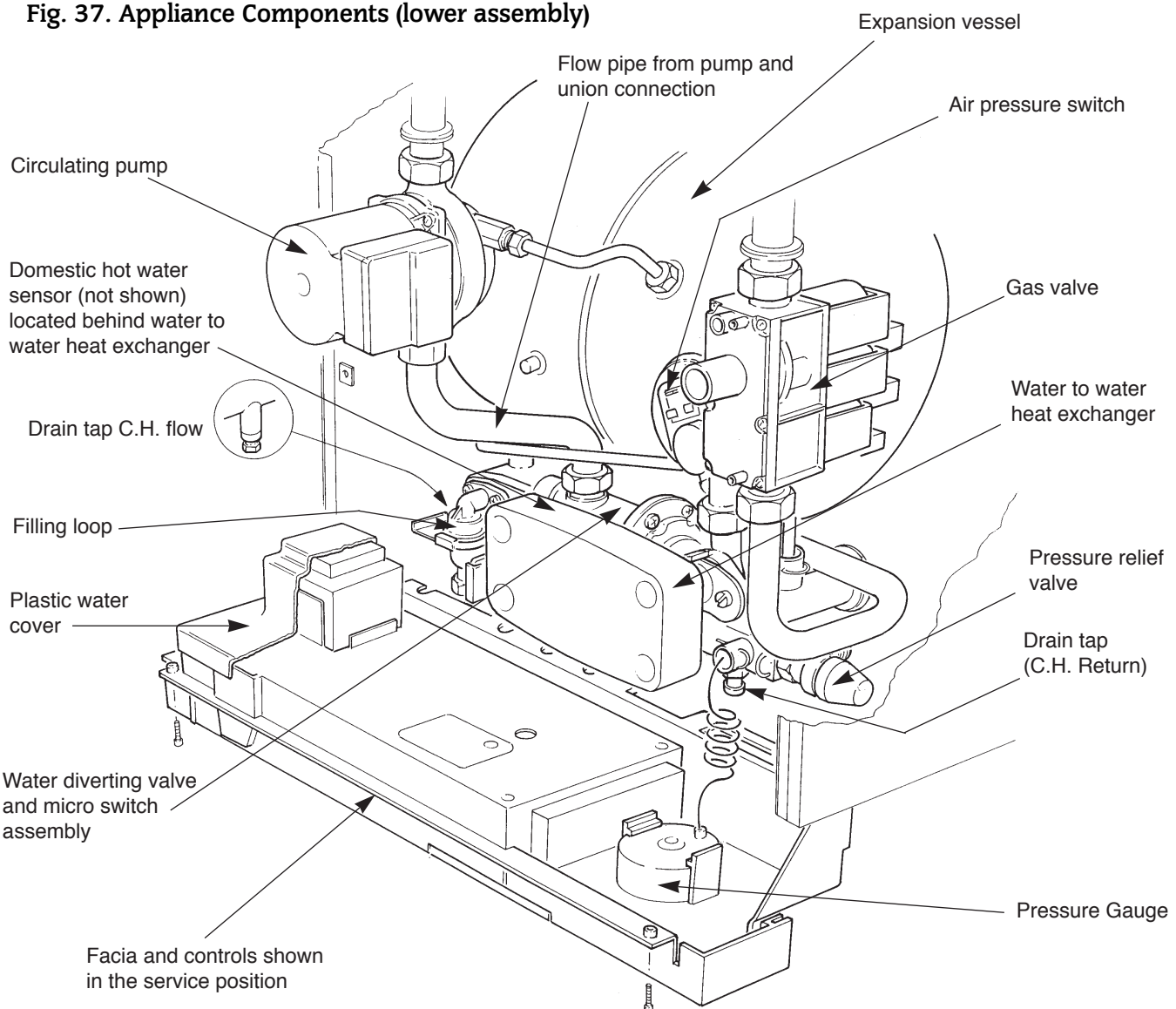
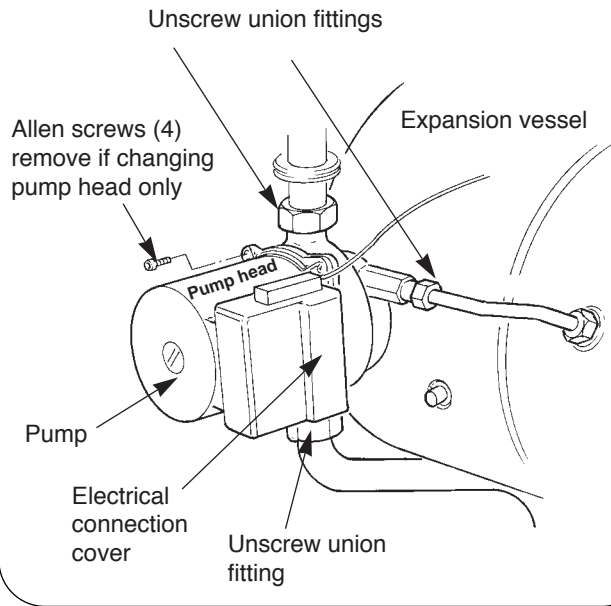

Fig. 38. Circulating pump



15. Pressure Relief Valve. See fig. 37 and 39.
 Check that the electricity supply to the appliance is turned off.
 Drain the central heating circuit as described in Section 14.2 (a).
 Hinge the facia panel down into the Servicing Position as described in Section 13.3 (c).
 Remove the bottom panel as described in Section 13.3 (d).
 Carefully ease the copper capillary tube to one side to clear the retaining clip. Pull out the retaining clip, undo the discharge pipe connection and remove the valve from the plastic manifold.
 Retain the clip, discard the valve
 Fit the replacement valve in reverse order. Reconnect the discharge pipe.
 Reassemble the appliance in the reverse order.
 Open the valves and fill and re-pressurise the system as described in Section 11.

16. Filling Loop. See figs. 37 and 39.
 Check that the electricity supply to the appliance is turned off.
 Drain the central heating circuit as described in Section 14.3 (a).
 Hinge the facia panel down into the Servicing Position as described in Section 13.3 (c).
 Drain the central heating circuit as described in Section 14.3 (a).
 Remove the two screws located on the left hand side. Slide the filling loop assembly to the left until clear of the water diverting valve. Remove from the appliance. Retain the screws and discard the filling loop.
 Fit the replacement assembly in the reverse order.
 Replace the 'O' ring seals.
 Open the valves and fill and re-pressurise the system as described in Section 11.1.
 Reassemble the appliance in the reverse order.

17. Water to Water Heat Exchanger. See figs. 37 and 39.
 Check that the electricity supply to the appliance is turned off.
 Drain the central heating and domestic hot water circuits as described in Sections 14.2 (a) and (b).
 Hinge down the facia panel into the Servicing Position as described in Section 13.3 (c).
 Remove the bottom panel as described in Section 13.3 (d).
 Remove the filling loop as described in Section 14.3 (16).
 Unscrew the left hand union connection to the diverter valve.
 Remove the screw and clamp from the right hand end of the heat exchanger.
 Pull the heat exchanger forwards about 10mm to release from the other two connections and remove from the appliance.
 The plastic hot water flow regulator is located in the cold water inlet accessible from the rear of the heat exchanger. Remove the flow regulator (push fit) and retain.
 Discard the heat exchanger retain the screw and clamp.
 Fit the replacement heat exchanger in the reverse order.
 Fit a new fibre sealing washer and 'O' ring seals. Lubricate the 'O' rings seals with silicone based grease.
 Reassemble the appliance in the reverse order.
 Open the valves and fill and re-pressurise the system as described in Section 11.

Fig. 39. Filling Loop, Water to Water Heat Exchanger and Domestic Hot Water Flow Regulator

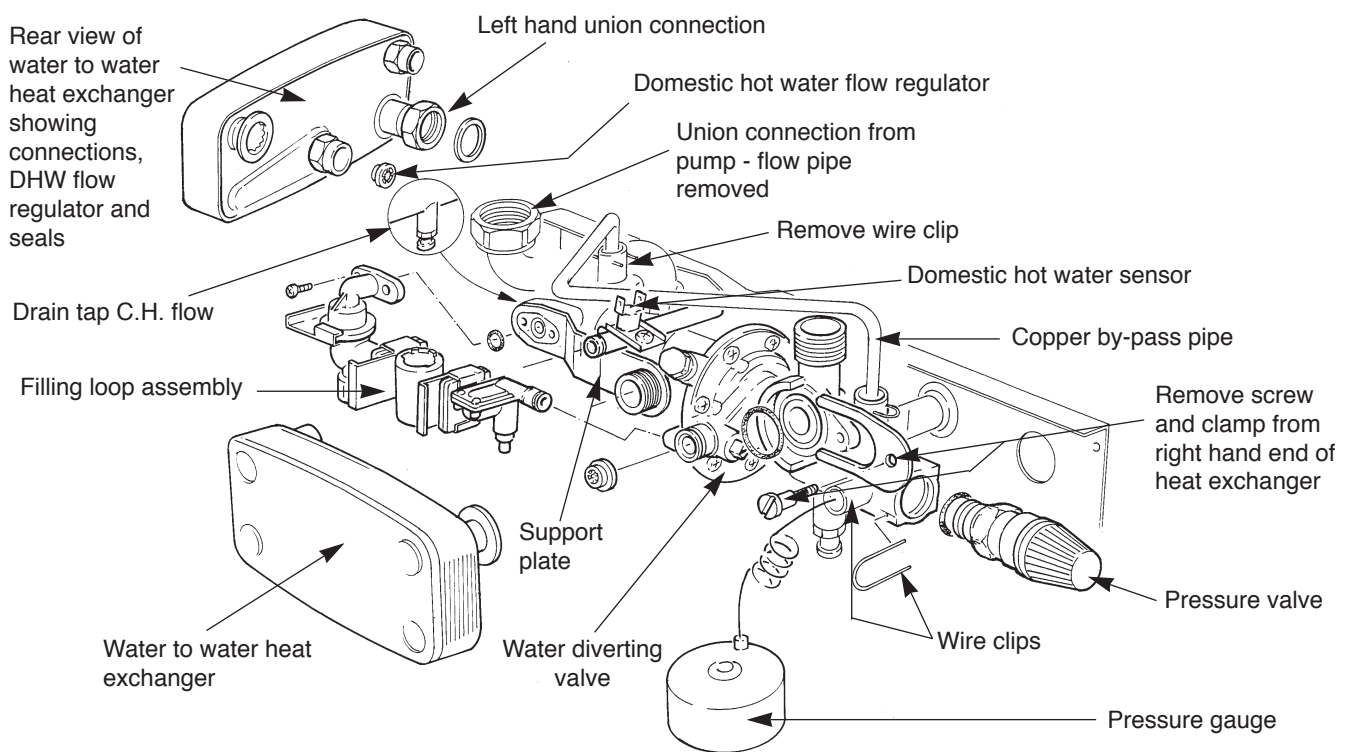

18. Water Diverting Valve Micro Switch Assembly.

See figs. 37 and 40.

Check that the electricity supply to the appliance is turned off. Hinge down the fascia panel into the Servicing Position as described in Section 13.3 (c).

To access the micro switch remove the bottom panel as described in Section 13.3 (d).

Using a pair of fine nosed pliers, pull the circlip off and remove the micro switch assembly from the valve. Pull off the black plastic cover and carefully ease the connections off the terminals.

Withdraw the switch assembly from the appliance and discard. Fit the replacement micro switch assembly in the reverse order. Polarity is not important.

Reassemble the appliance in the reverse order.

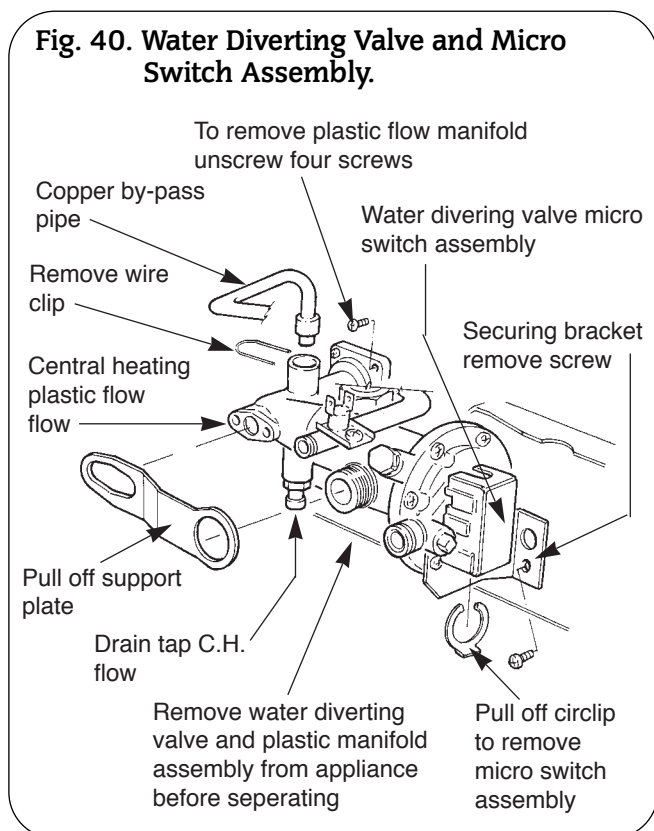

19. Water Diverting Valve. See figs. 18, 37, 39 and 40.

Check that the electricity supply to the appliance is turned off. Drain the central heating and domestic hot water circuits as described in Sections 14.2 (a) and (b).

Hinge down the fascia panel into the Servicing Position as described in Section 13.3 (c).

Remove the bottom panel, filling loop, water to water heat exchanger and micro switch assembly as described in Section 13.3 (d), and Sections 14.3 (16), (17) and (18).

Pull off the support plate locating the water diverting valve to the central heating plastic flow manifold on the left hand side of the appliance.

Remove the wire clip securing the copper by-pass pipe to the flow manifold.

Retain the support and plate and wire clip.

Carefully ease the by-pass pipe out of the manifold and allow the pipe to swing forwards to clear the manifold connection.

Remove the screw securing the bracket, located at the right hand end of the water diverting valve, to the appliance casing.

Remove the four screws located at the left hand side securing plastic manifold to the appliance.

Remove the water diverting valve and plastic manifold assembly clear of the appliance.

Ease the water diverting valve out of the plastic manifold.

Remove the securing bracket from the valve and the water filter from the valve cold water inlet.

Retain the plastic manifold, fixing screws, support bracket and water filter.

Discard the water diverting valve.

Reassemble the original support bracket, water filter and new 'O' ring seals to the replacement valve.

Lubricate the 'O' ring seal and push the plastic flow manifold onto the valve.

Reassemble the water diverting valve and plastic manifold assembly to the appliance in the reverse order.

Ensure all 'O' ring seals and fibre washers are renewed and replaced correctly and the 'O' rings are lubricated.

Reassemble the appliance in the reverse order.

Open the valves and fill and re-pressurise the system as described in Section 11.1.

20. Inlet Water Filter. See figs. 18,37,39 and 40.

Check that the electric supply to the appliance is turned off.

Drain the central heating and domestic circuits as described in Sections 14.2 (a) and (b).

Hinge down the fascia panel into the servicing position as described in Section 13.3 (c).

Follow the procedures as described in Section 14.3 (19) and remove the water diverting valve from the appliance.

Remove the water filter from the cold water inlet.

Discard or clean the filter.

Fit the replacement filter (push fit) in the reverse order.

Reassemble the appliance in the reverse order following the procedure described in Section 14.3 (19).

Open the valves and fill and re-pressurise the system as described in Section 11.1.

21. Domestic Hot Water Flow Regulator. See fig. 39.

Check that the electricity supply to the appliance is turned off.

Drain the central heating and domestic hot water circuits as described in Sections 14.2 (a) and (b).

Hinge down the fascia panel into the Servicing Position as described in Section 13.3 (c).

Remove the water to water heat exchanger assembly as described in Section 14.3 (17).

The hot water plastic flow restrictor is housed in the cold water inlet to the heat exchanger and is a push fit. Remove the flow regulator and discard.

Fit the replacement flow regulator with the direction of flow indicated on fig. 39.

Reassemble in the reverse order ensure all the fibre washers and 'O' rings are in place.

Reassemble the appliance in the reverse order.

Open the valves and fill and re-pressurise the system as described in Section 11.1.

22. Expansion Vessel. See figs. 32, 37, 38 and 39.

Check that the electricity supply to the appliance is turned off.

Drain the central heating and domestic hot water circuits as described in Sections 14.2 (a) and (b).

Hinge down the fascia panel into the Servicing Position as described in Section 13.3 (c).

Remove the air pressure switch, gas to water heat exchanger, circulating pump, filling loop and water to water heat exchanger as described in Section 14.3 (2), (5), (14), (16) and (17).

Unscrew the union connection on top of the water diverting valve and remove the flow pipe.

Pull out the wire clip from each end of the copper by-pass pipe and remove the pipe.

Reach under the inner casing and remove the securing clip from the right hand pipe connection.

Ease the pipe out of the connection.

From inside the inner casing release the rear pipe from the push-fit location. Release the sealing grommet from the base of the inner casing.

Feed the pipe and sealing grommet clear of the inner casing. Retain all components and securing clips removed.

Cut the plastic strap securing the expansion vessel to the appliance casing. Discard the strap. Remove the expansion vessel clear of the appliance. Disconnect the pipe from the expansion vessel. Retain the pipe and discard the expansion vessel.

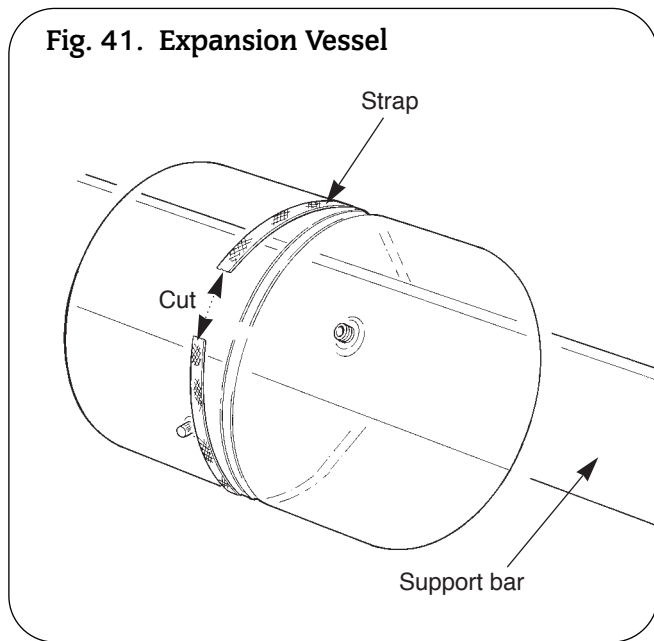

Reassemble the expansion vessel in the reverse order. Ensure all the fibre washers and 'O' rings are in place and all securing clips are replaced correctly. Reassemble the appliance in the reverse order. Open the valves and fill and re-pressurise the system as described in Section 11.1.

23. Control Board. See figs. 27 and 42. Check that the electricity supply to the appliance is turned off. Remove the three screws fixing the fascia bottom panel to the fascia. Remove the fascia bottom panel. Retain the panel and screws.

Carefully pull off all the connectors. Disconnect the mains supply lead at terminal ST 12 and the earth connection at the back. Pull off the three plastic control knobs. Take care not to damage the knobs when pulling off. Retain the knobs. Hinge down the fascia panel into the Servicing Position as described in Section 13.3 (c). Remove the plastic water cover. Remove the four corner screws on the back of the fascia and separate the metal back panel from the plastic fascia. Ease off the two spark electrode lead connections. Release the plastic catch at each of the four mounting posts pulling the control board forwards approximately 3mm to prevent the plastic catch from returning. Pull the board off the remainder of the mounting posts until it is free.

Unplug the transformer from rear of the board. Discard the control board retain the transformer. Plug in the transformer to the replacement control board. The transformer will fit in one direction only. Locate the replacement control board over the four mounting posts and push back squarely until the plastic catch on the end of each post clicks into place. Reassemble in the reverse order and ensure:

- i) the spark electrode leads are re-connected. Polarity is not important.
- ii) the connectors are fitted to the correct terminals. Connectors are not interchangeable and will only fit the terminals from which they were removed.

Reassemble the fascia panel and fascia bottom panel in the reverse order. When replacing the control knobs ensure the knob with the shortest shaft is fitted to the left hand control position.

24. Transformer. See figs. 27, and 42. Check that the electricity supply to the appliance is turned off. Remove the control board as described in Section 14.3 (23). Unplug the transformer from rear of the board. Discard the transformer retain the control board. Plug in the replacement transformer to the control board. The transformer will fit in one direction only.

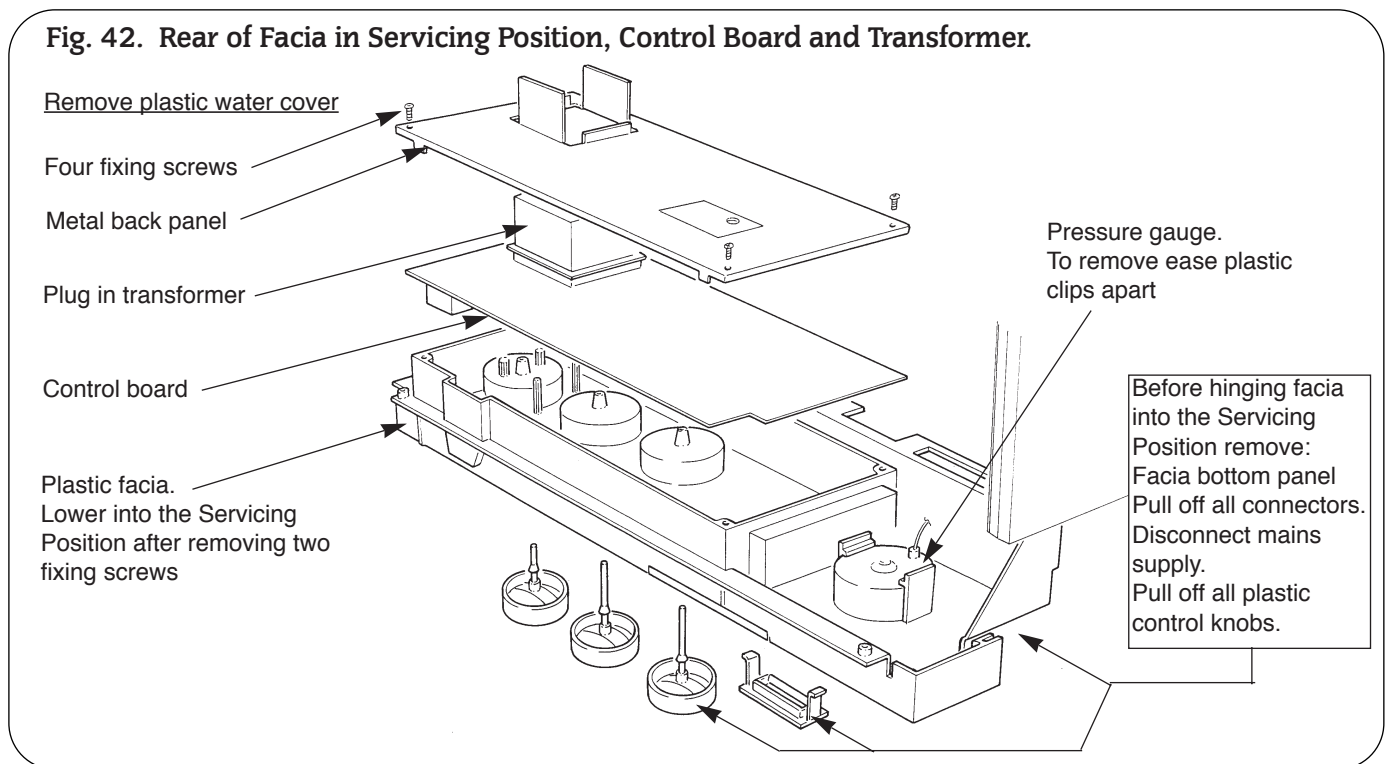

25. **Secondary Heat Exchanger.** See figs. 32, 33, 34, 35, 36, 37, 39, and 43.

Check that the electricity supply to the appliance is turned off.
 Drain the central heating circuit as described in Section 14.2 (a).
 The secondary high efficient heat exchanger is housed in a stainless steel box. The assembly is located inside and at the rear of the inner casing.

Fig. 43. Secondary Heat Exchanger

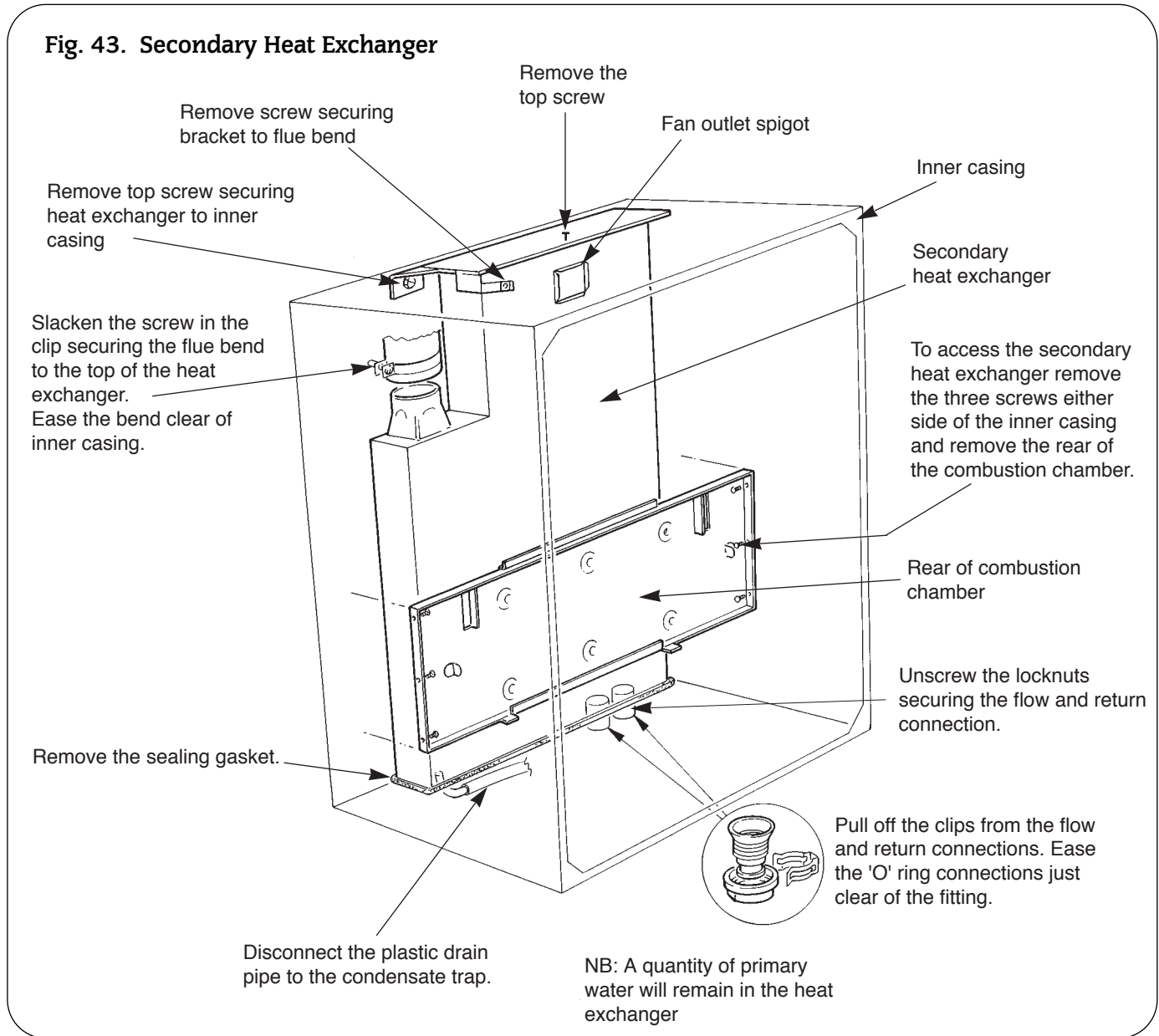

To access the assembly:

- i) Remove the inner casing cover, fan, flue hood assembly and disconnect the overheat thermostat as described in Section 13.3 (b), (e), (f) and Section 14.3 (4).
- ii) Remove the combustion chamber front and sides assembly and unhook the securing rods out of the locations in the inner casing as described in Section 13.3 (g).
- iii) Remove the gas to water heat exchanger, rear fibre insulation pad and burner assembly as described in Section 14.3 (5), (6) and (7).
- iv) Unscrew the three screws either side of the inner casing securing the rear of the combustion chamber to the inner casing and remove.
- v) Slacken the screw in the clip securing the flue bend to the top of the heat exchanger. Ease the bend out of the appliance.
- vi) Remove gas valve section 14.3 (c).
- vii) Remove the screw located on top of the inner casing.

Retain all components removed from the appliance.

To remove the assembly:

- i) Remove the top screw securing the heat exchanger to the inner casing. Retain the screw.
- ii) Pull off the two clips securing the flow and return pipes to the heat exchanger located under the inner casing. Ease the 'O' ring connections just clear of the fittings.
- Warning:** A quantity of primary water will remain in the heat exchanger and pipework.
- iii) Unscrew the two union lock nuts securing the flow and return connections to the inner casing.
- iv) Disconnect the plastic drain pipe to the condensate trap.
- v) Ease the assembly out of the locations in the base of the inner casing and clear of the appliance.

If a blockage is suspected the stainless steel box may be flushed out with clean water and reassembled.
 Alternatively discard the assembly and sealing gasket and replace with a new assembly.

Reassemble the appliance in the reverse order. Ensure all gasket seals and 'O' connections are made correctly. Open the valves fill and re-pressurise the system as described in Section 11.1.

26. Condensate Syphon.

See fig. 37, 43 and 44.

Check that the electricity supply to the appliance is turned off. Hinge down the fascia panel into the Servicing Position as described in Section 13.3 (c). Disconnect condensate drain pipe from condensate syphon. Unscrew the locknut securing the condensate syphon to the support bracket. Lift the trap clear of the bracket and discard. Reassemble in reverse order.

Fig. 44. Condensate Syphon

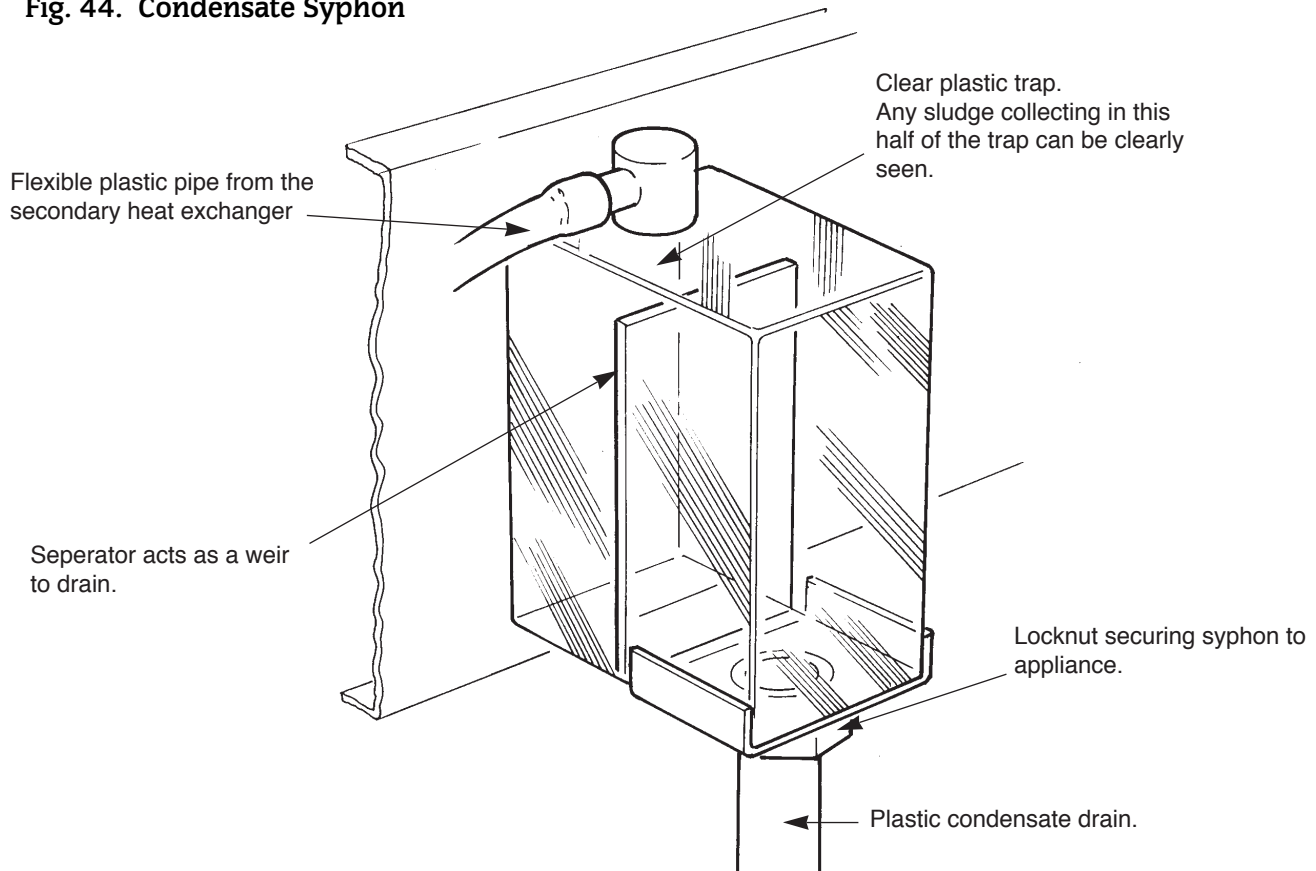

27. Pressure Gauge.

See figs. 37, 39 and 42.

Check that the electricity supply to the appliance is turned off. Drain the central heating and domestic hot water circuits as described in Sections 14.2. (a) and (b). Hinge down the fascia panel into the Servicing Position as described in Section 13.3. (c). Pull out the retaining clip and ease the capillary tube out of the CH return manifold. The pressure gauge is secured into the fascia with two plastic clips. Ease the clips apart and remove the pressure gauge clear of the fascia. Discard the pressure gauge and retain the clip. Reassemble the appliance in the reverse order.

Open the valves fill and repressurise the system as described in section 11.1.

15. Short Parts List

Key No.	G.C. No.	Part	Manufacturer's Reference	Qty	WHS Part No.
26	378 312	Gas Valve	Junkers Bosch, type CE 426	1	8 747 003 366 0
78	375 695	Burner – Natural Gas	Aeromatic, ref. AC 23/05 3582	1	8 716 142 602 0
80	173 091	Burner Injector – Natural Gas	Stereomatic, type 7, 4.5mm dia.	1	8 716 140 208 0
81	375 697	Spark Electrode Assembly	Bucclench, ref. BE/3462/SI	1	8 716 142 100 0
82	E01 612	Flame Sensor	Bucclench, ref. BE/3461/SI	1	8 716 120 345 0
95	299 515	Ignition Harness	Bucclench, ref. BE/3469/SI	1	8 716 120 229 0
61	299 352	Gas to Water Heat Exchanger	Giannoni, ref. PR22 323 003, spec. D2107	1	8 716 142 800 0
68	E00 716	Automatic Air Vent	Intermes, ref. 02.05.010	1	8 716 140 500 0
85	299 506	System Pressure Gauge	Cewal, spec. D2111	1	8 716 142 300 0
40	375 699	Pressure Relief Valve	Caleffi, ref. 312439	1	8 716 142 404 0
29	E04 572	Circulating Pump	Grundfoss	1	8 716 143 108 0
25	E04 568	Expansion Vessel	Zilmet	1	8 716 142 515 0
42	299 353	Water to Water Heat Exchanger	Giannoni, ref. PVW 12 E, spec. D2108	1	8 716 142 900 0
34	173 005	Diverter Valve	Giannoni	1	8 716 156 746 0
104	379 215	DHW Flow Restrictor	Type E – White 8 litre	1	8 716 141 054 0
105	178 416	Domestic Water Filter	MPM, V3326	1	8 716 148 400 0
109	E01 840	Filling Loop Assembly		1	8 716 120 320 0
84	E04 591	Circuit Board – RSF	Junkers Bosch, type Heatronic II AE	1	8 748 300 313 0
96	299 516	Transformer	ERA, ref. BV 066-0188.0	1	8 747 201 248 0
65	299 497	Fan Assembly – RSF		1	8 716 121 192 0
66		Air Pressure Sensing Probe – RSF	WHS, Drg. 010548	1	8 716 141 190 0
129	E04 598	Differential Air Pressure Switch – RSF		1	8 716 156 744 0
60	375 696	Thermister Sensor	Elmwood	2	8 716 142 384 0
62	173 015	Overheat Thermostat	Elmwood, ref. 2455 R - 98 - 789	1	8 716 142 303 0
133	299 354	Combustion Chamber Insulation Pack	WHS	1	7 716 192 204 0
134	299 355	Fibre Washer Pack	WHS	1	7 716 192 205 0
135	E04 651	'O' Ring Pack	WHS	1	7 716 192 239 0
136	299 357	Fuse Pack	WHS	1	7 716 192 206 0
78	173 012	Burner – LPG	Aeromatic, AC23/05 3583	1	8 716 142 646 0
80	E00 741	Burner Injector – LPG	Stereomatic, type 7, 2.7mm dia.	1	8 716 156 373 0
201	E04 617	Secondary Heat Exchanger	WHS	1	8 716 121 205 0

Accessories for 26CDi Xtra

G.C. No.	Part	WHS Part No.
E04 654	Standard 1M Flue Duct & Terminal	7 716 191 059
E04 655	2M FLue Duct & Terminal	7 716 191 060
299 361	Digital Single Channel Programmer	7 716 192 003
299 360	Mechanical Single Channel Programmer	7 716 192 002
E01 053	Digistat CD (Radio Controlled Room Thermostat)	7 716 192 006
E01 613	Wall Spacing Frame	7 716 192 111
	Pre-system Filling Loop	7 716 192 102
E01 614	Mini Expansion Vessel	7 716 192 105
299 275	Internal Flue Fixing Kit	7 716 191 018
	Vertical Flue Terminal Kit	7 716 191 070
	1 Metre Vertical Flue Extension Kit	7 716 191 071
E04 652	Gas Conversion Kit	7 716 192 238

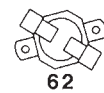
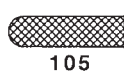
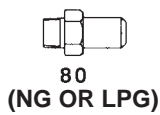
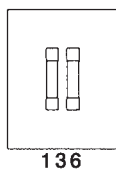
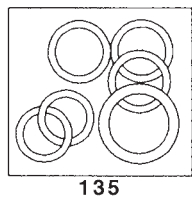
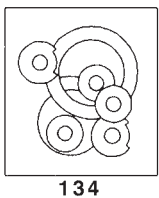
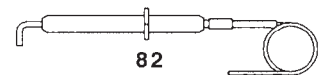
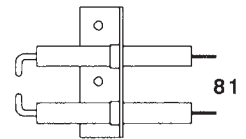
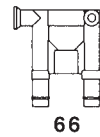
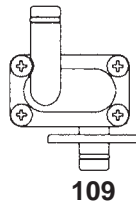
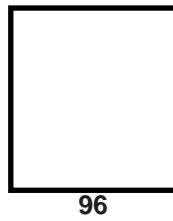
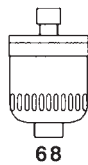
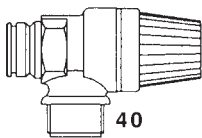
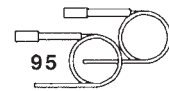
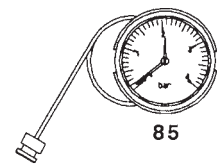
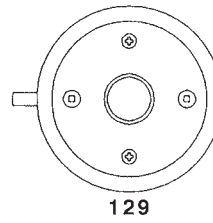
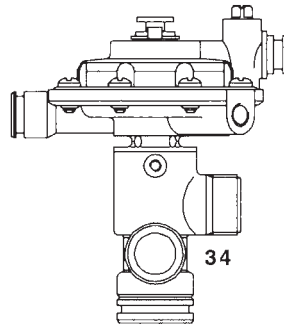
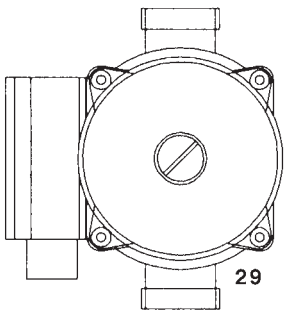
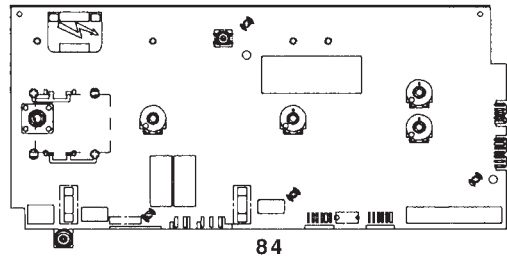
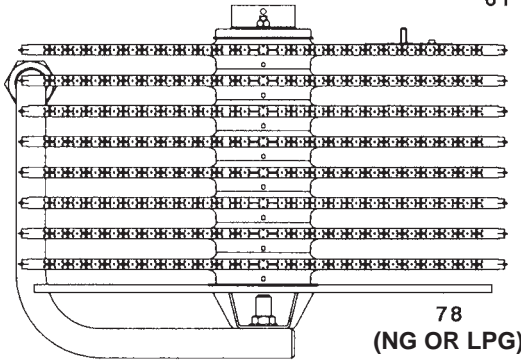
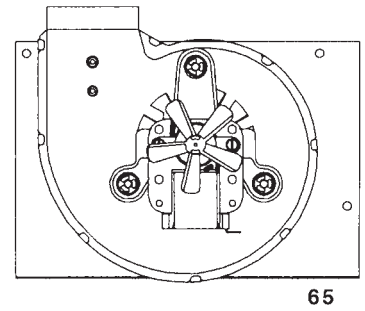
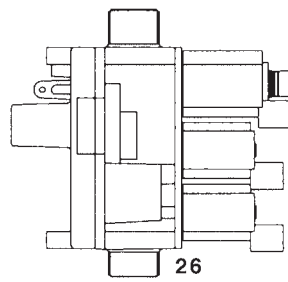
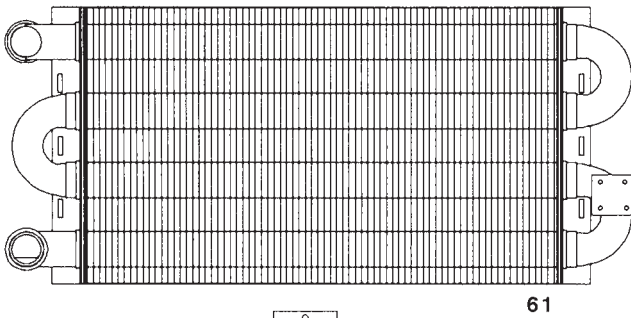
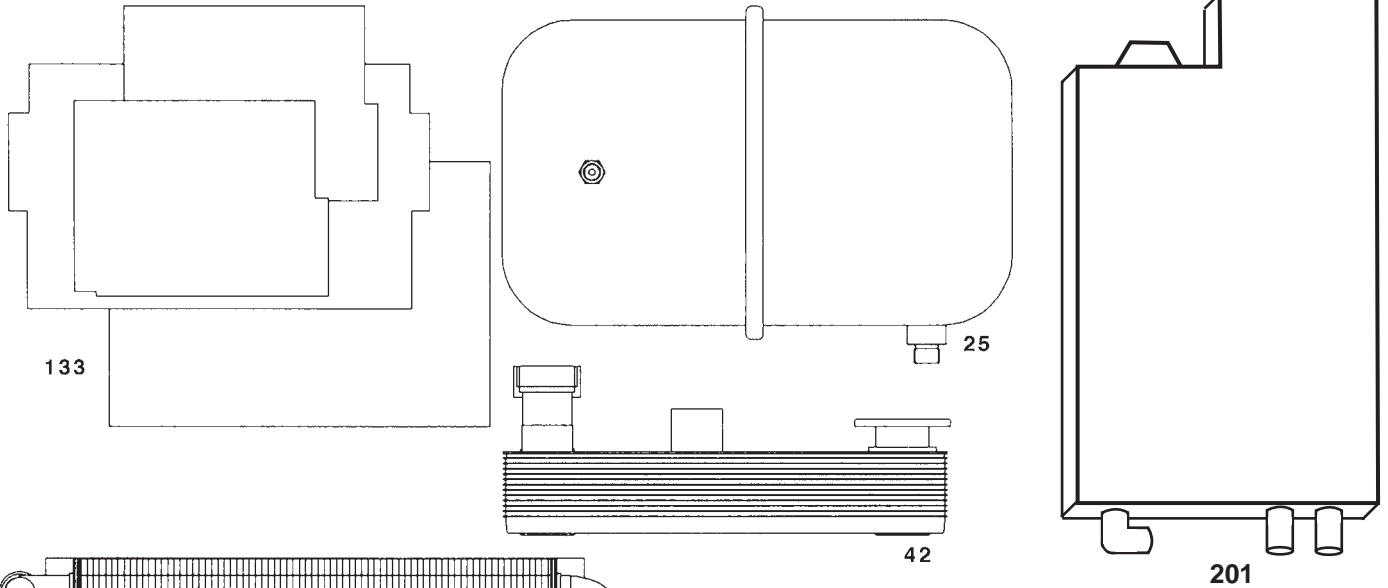

16. Operational Flow Diagrams

CENTRAL HEATING FUNCTION

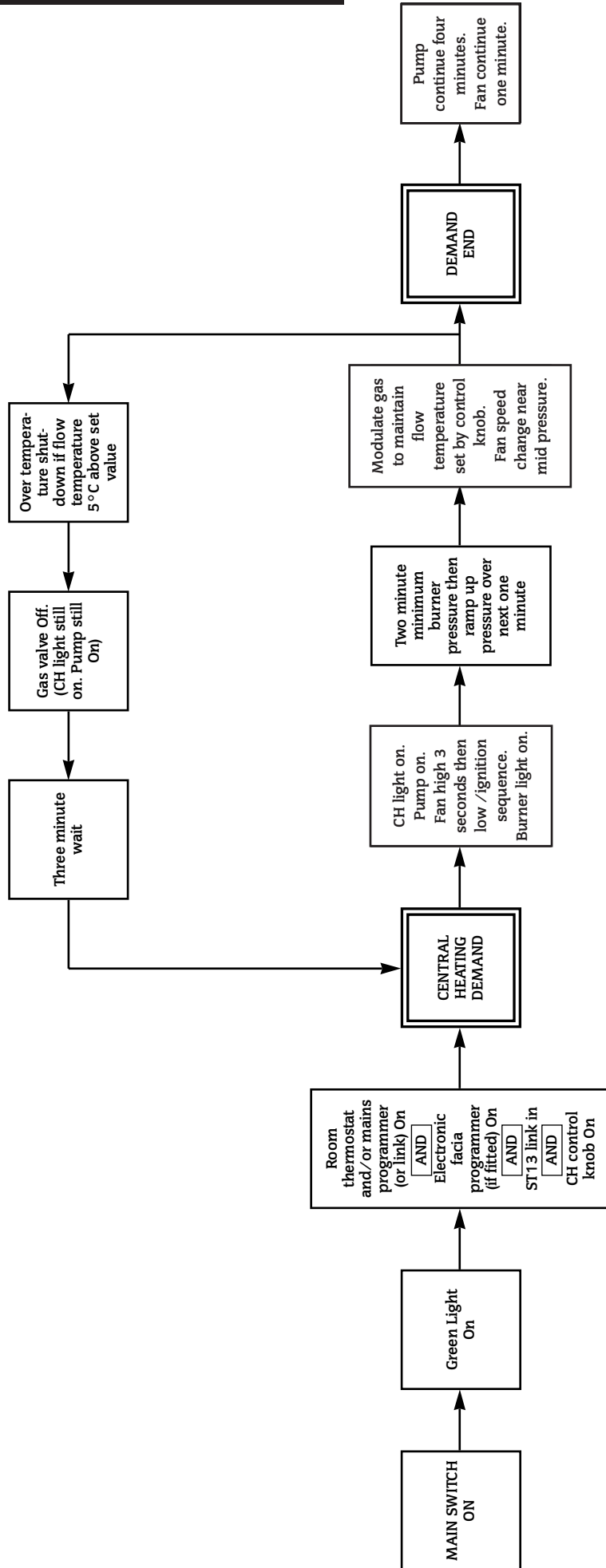

DOMESTIC HOT WATER FUNCTION

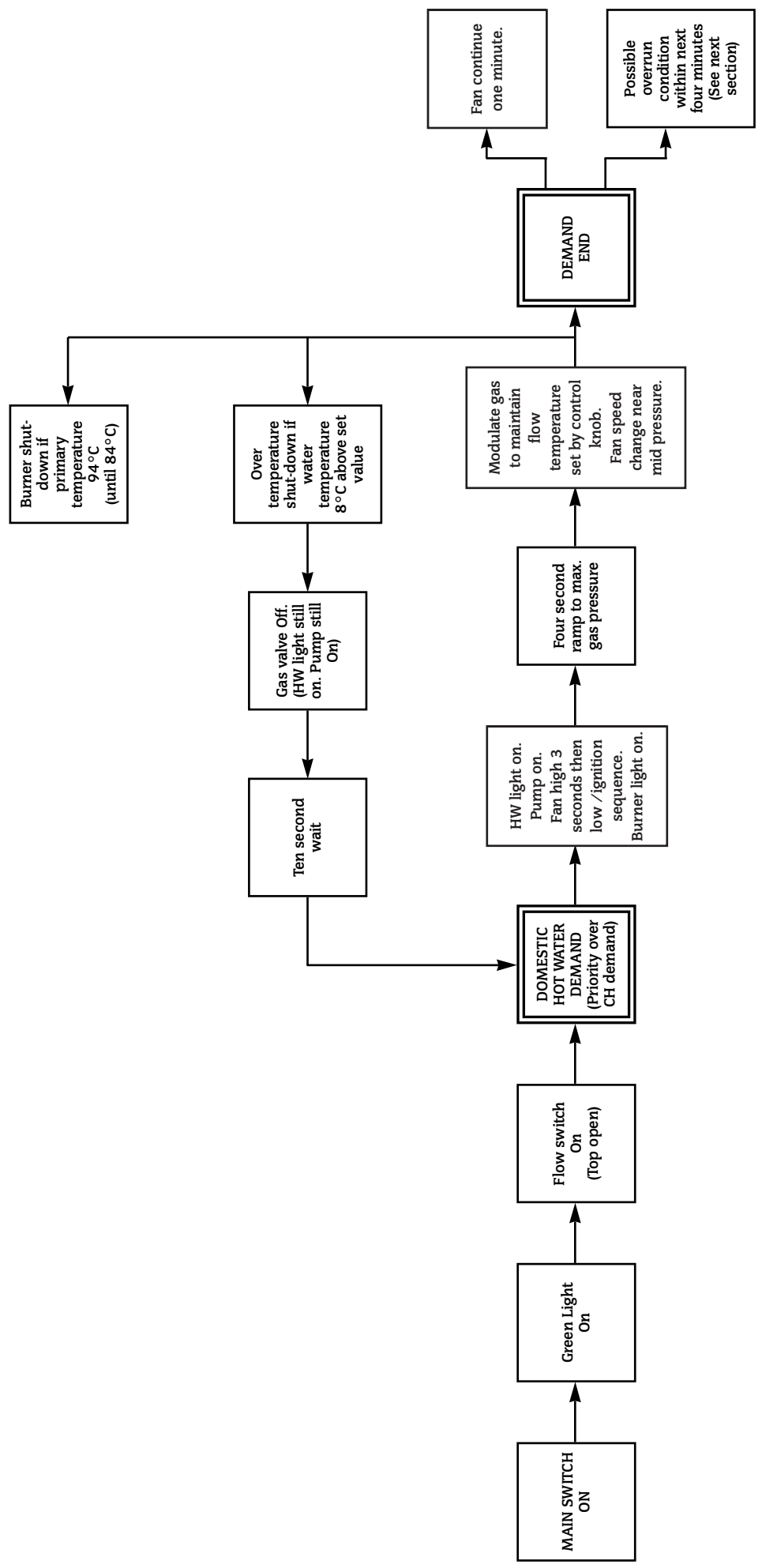

OVERRUN FUNCTION

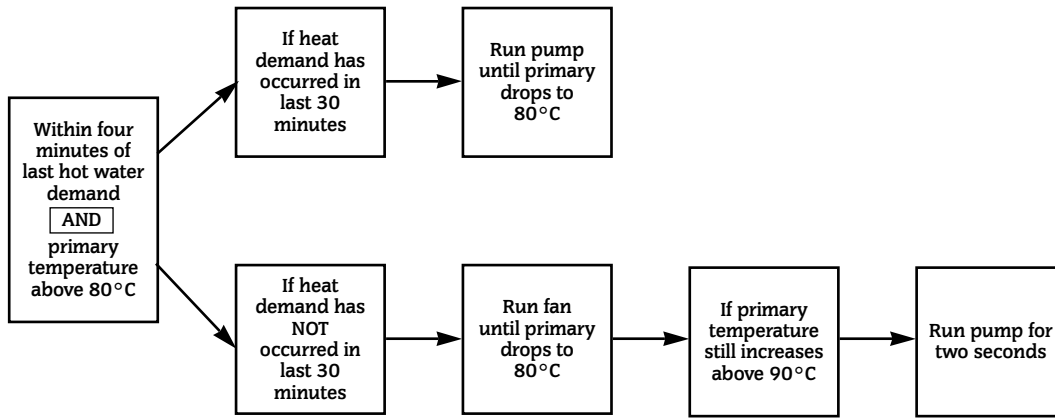

AUTOFROSTAT FUNCTION

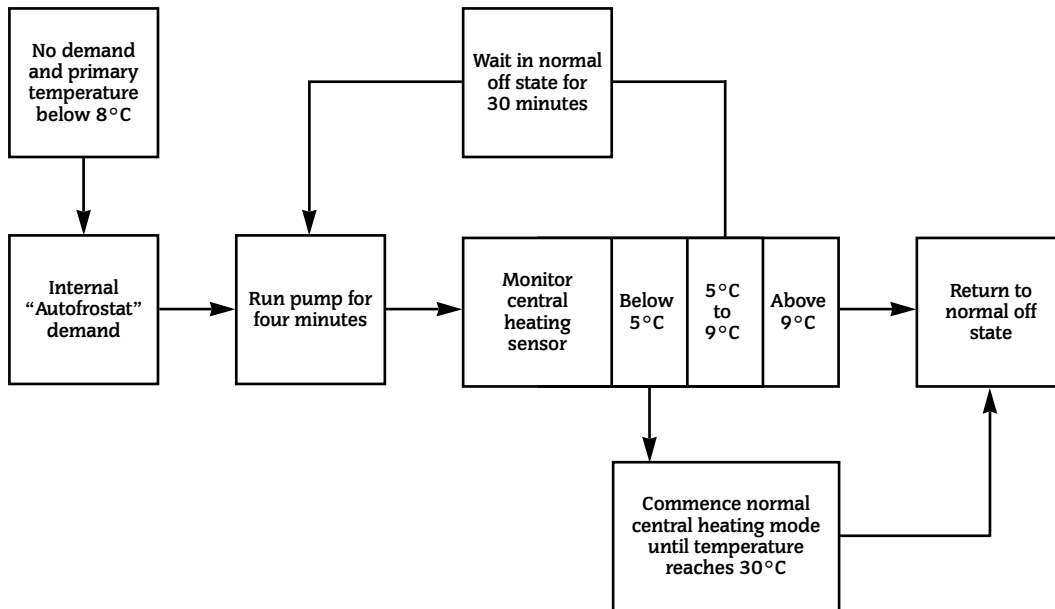

17. Fault Finding

Note: This fault-finding information is for guidance only. Worcester Heat Systems cannot be held responsible for costs incurred by persons not deemed to be competent.

The electronic control system for this boiler incorporates four lights on the facia. These are used to show normal operating status. But as a secondary function, by flashing, they can also be used to help provide fault diagnostics. Therefore, with individual or groups of lights being permanently off, on or flashing, every normal fault can be identified.

To use the fault finding system, select a box below which represents the light situation during your fault. Then refer to the appropriate following section. This fault-finding system assumes that the appliance has been operating correctly until the time of failure.

PRELIMINARY CHECKS

Preliminary electrical system checks are the first electrical checks to be carried out during a fault-finding procedure. On completion of the Service/Fault-Finding task which has required the breaking and remaking of electrical connections, check (a) EARTH CONTINUITY, (b) SHORT CIRCUIT CHECK, (c) POLARITY and (d) RESISTANCE TO EARTH.

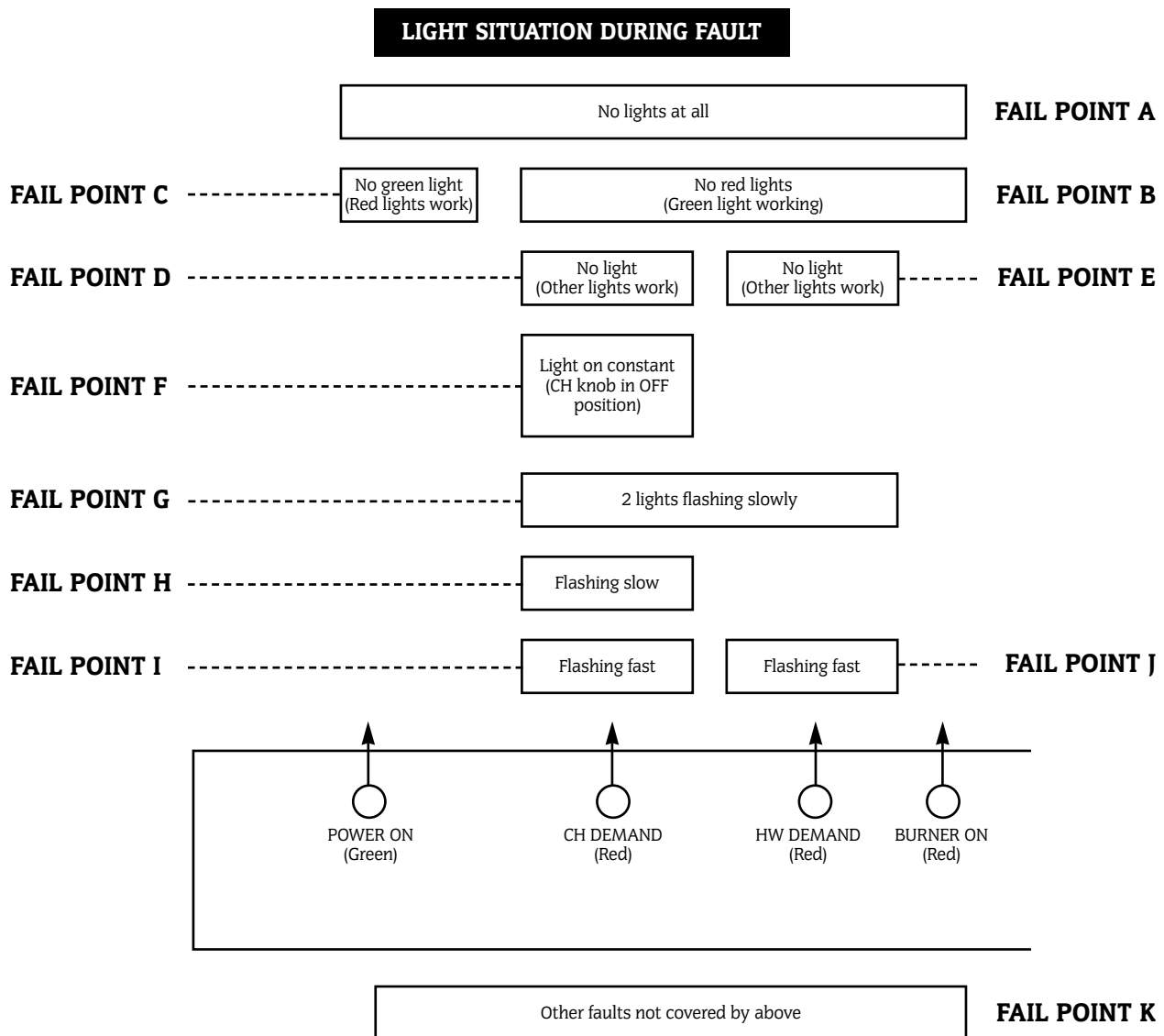

Note:

- Slow flash is once per second, fast flash is five times per second.
- Slow flash can only be cleared by using the facia reset button (press for at least one second).
- Fast flash is cleared by removing fault and/or main switch off/on.

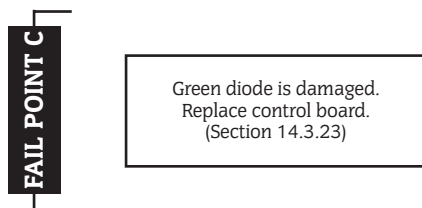
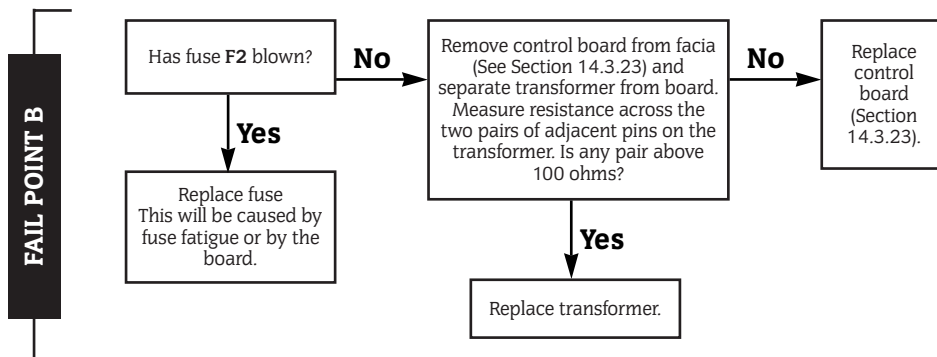
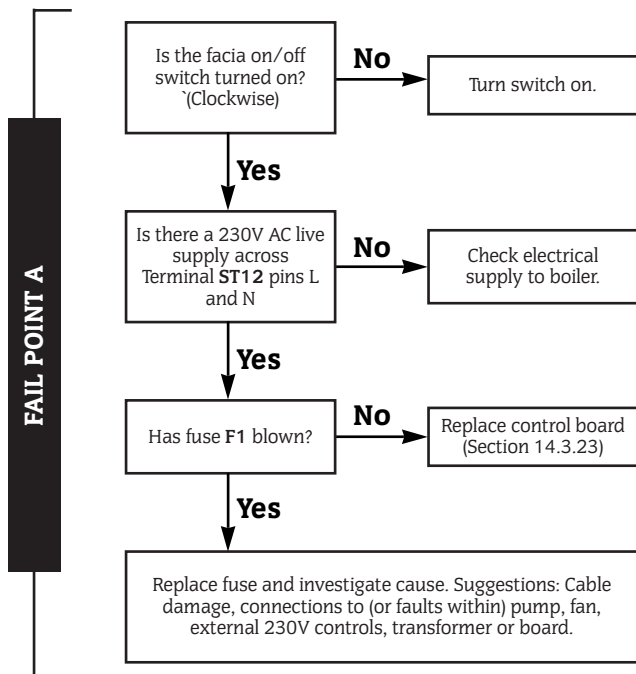

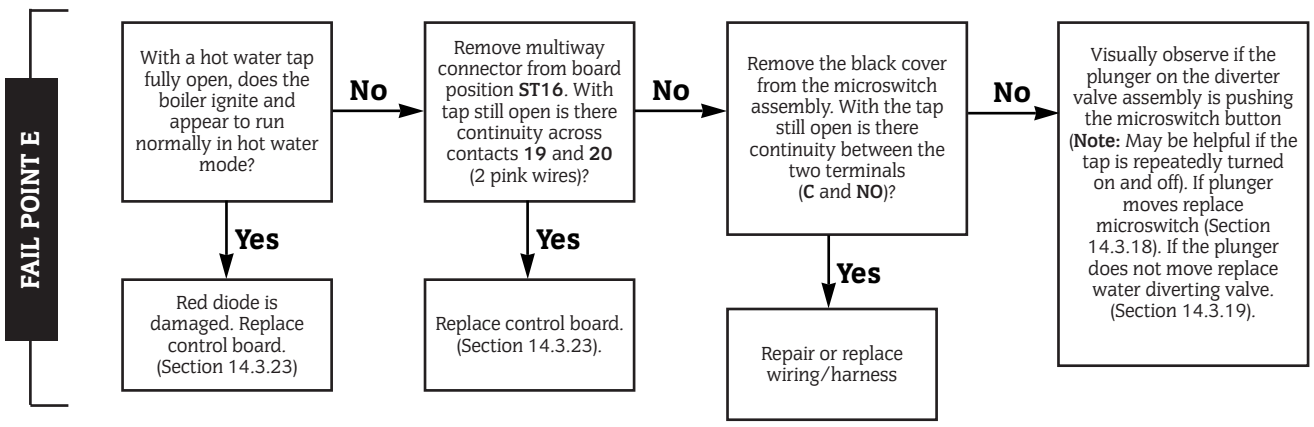
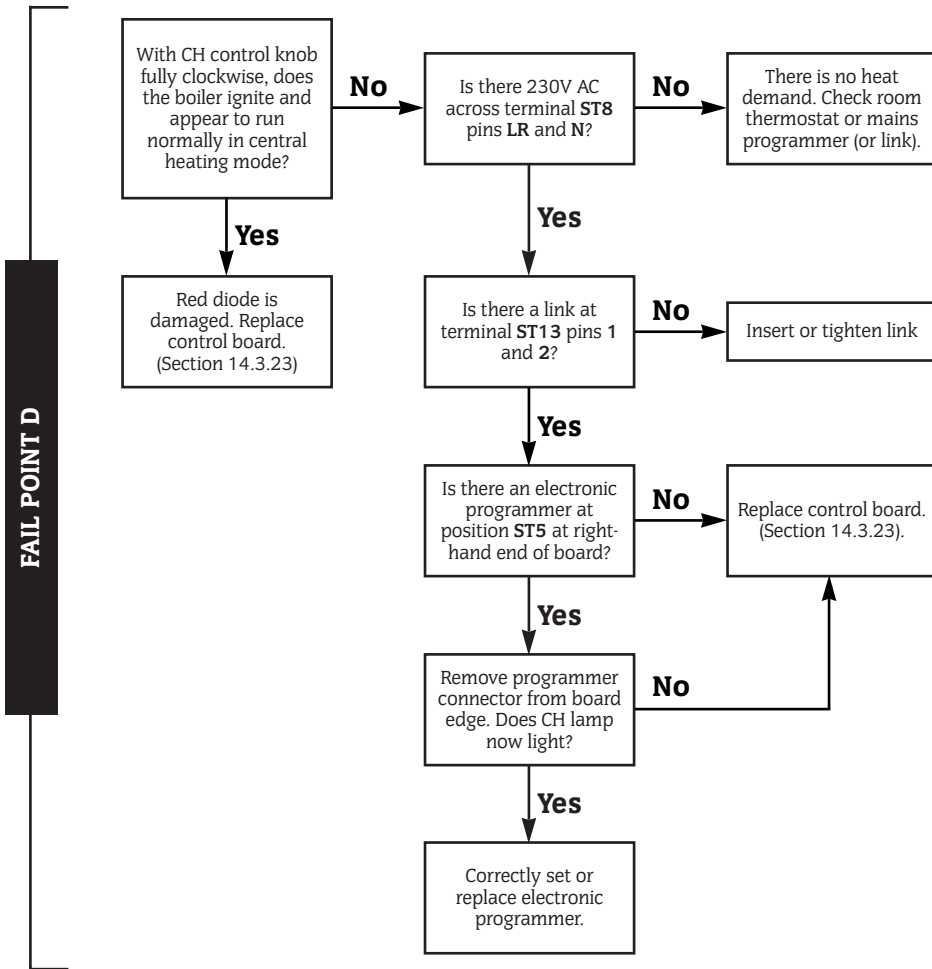

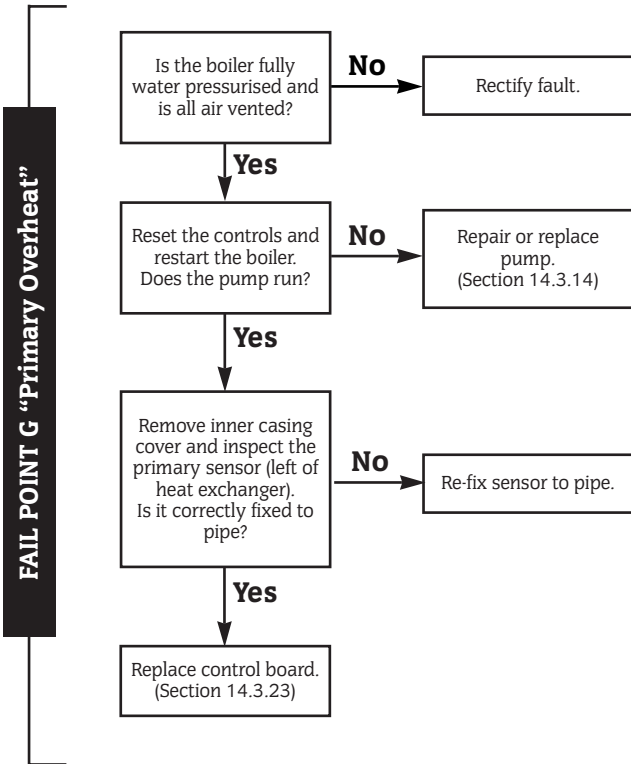
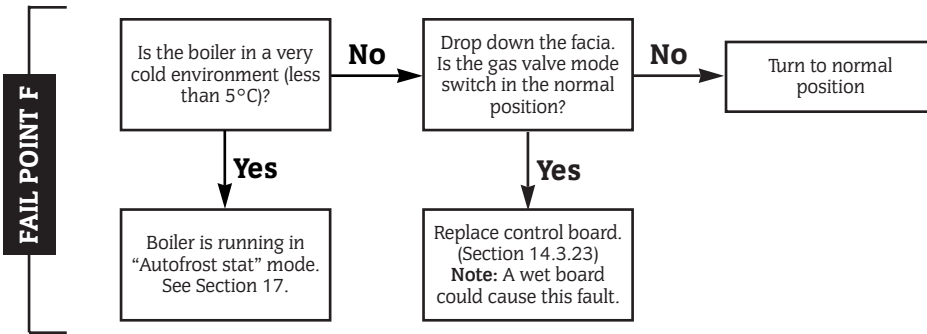

FAIL POINT H "Burner Lockout"

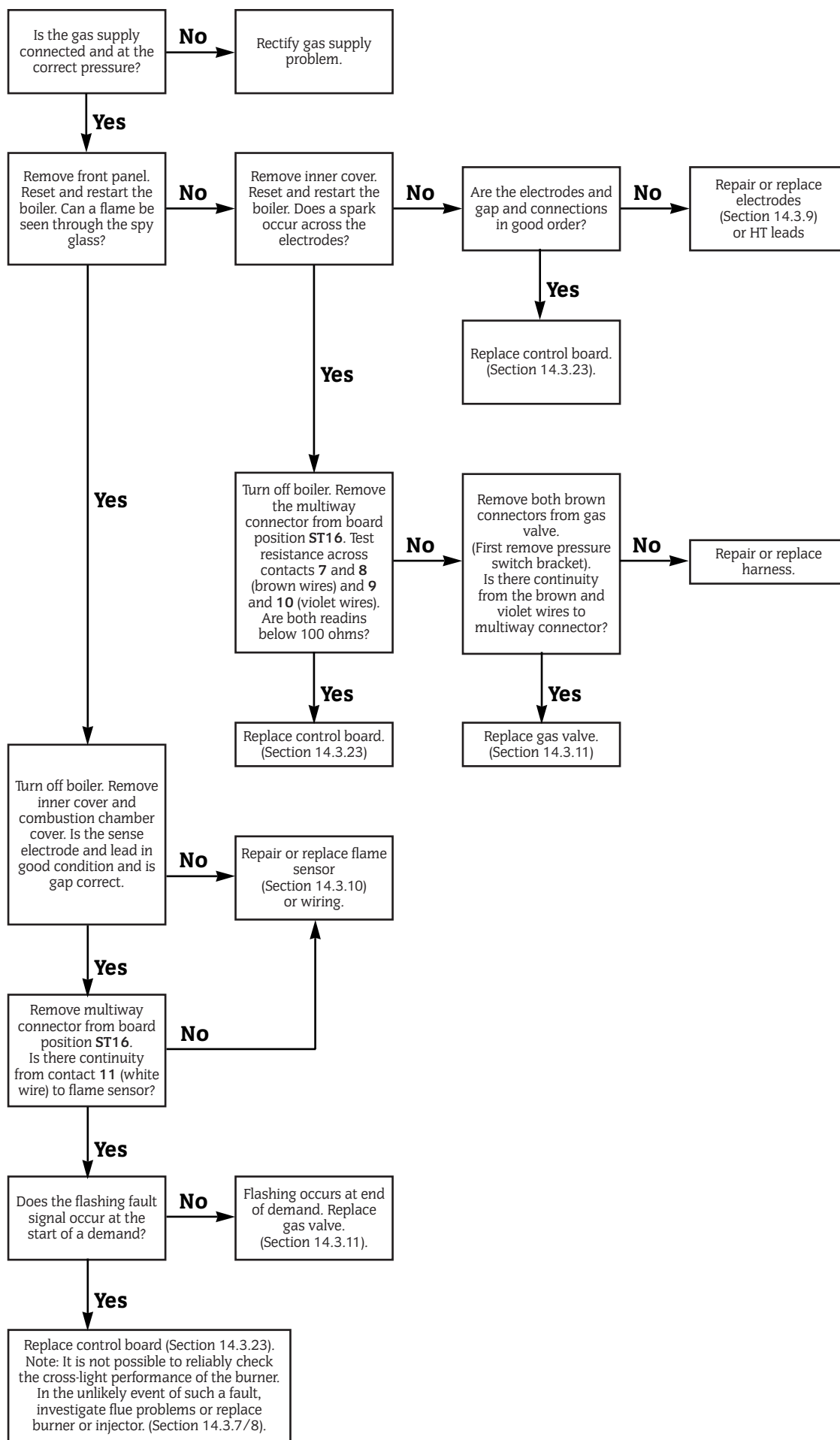

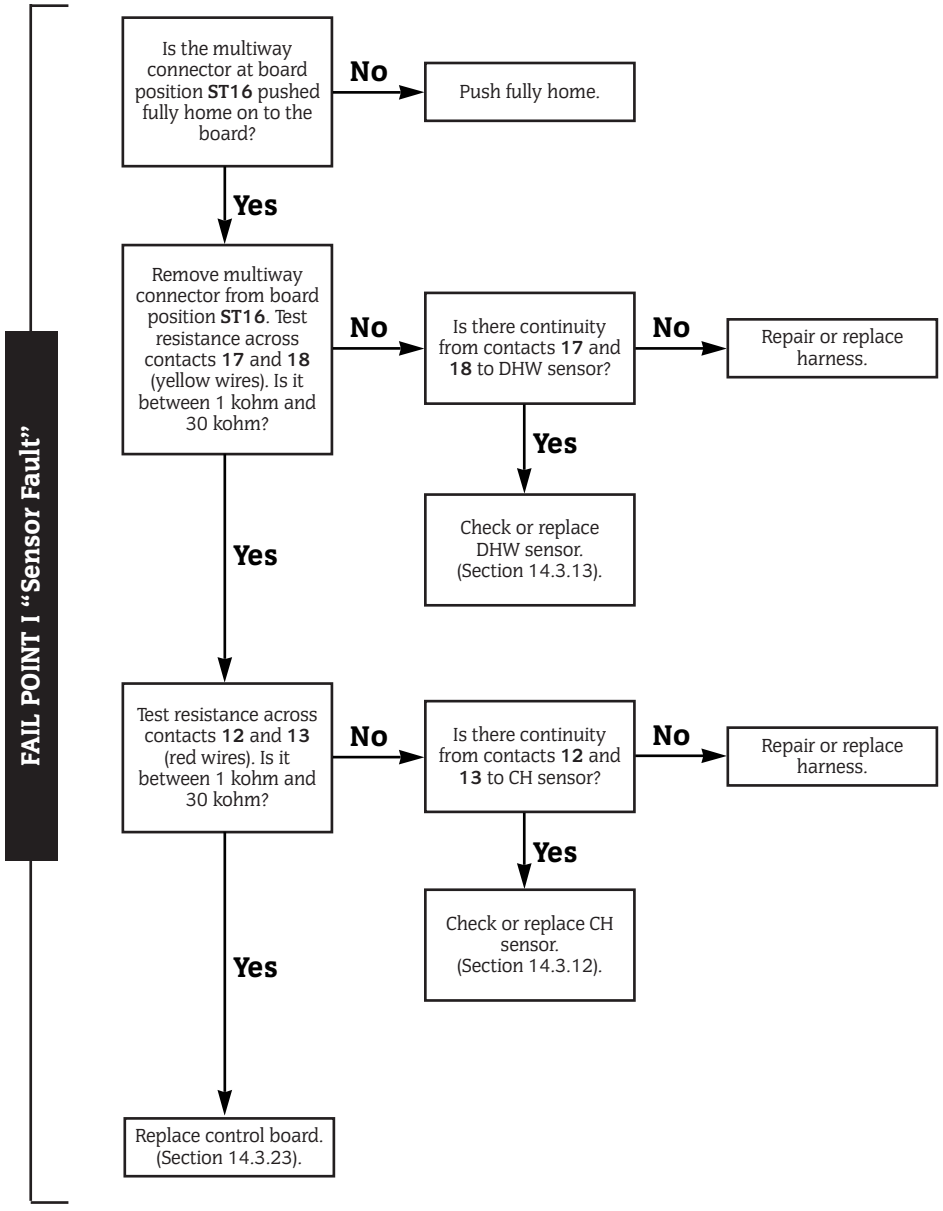

FAIL POINT J "Air Pressure Fault"

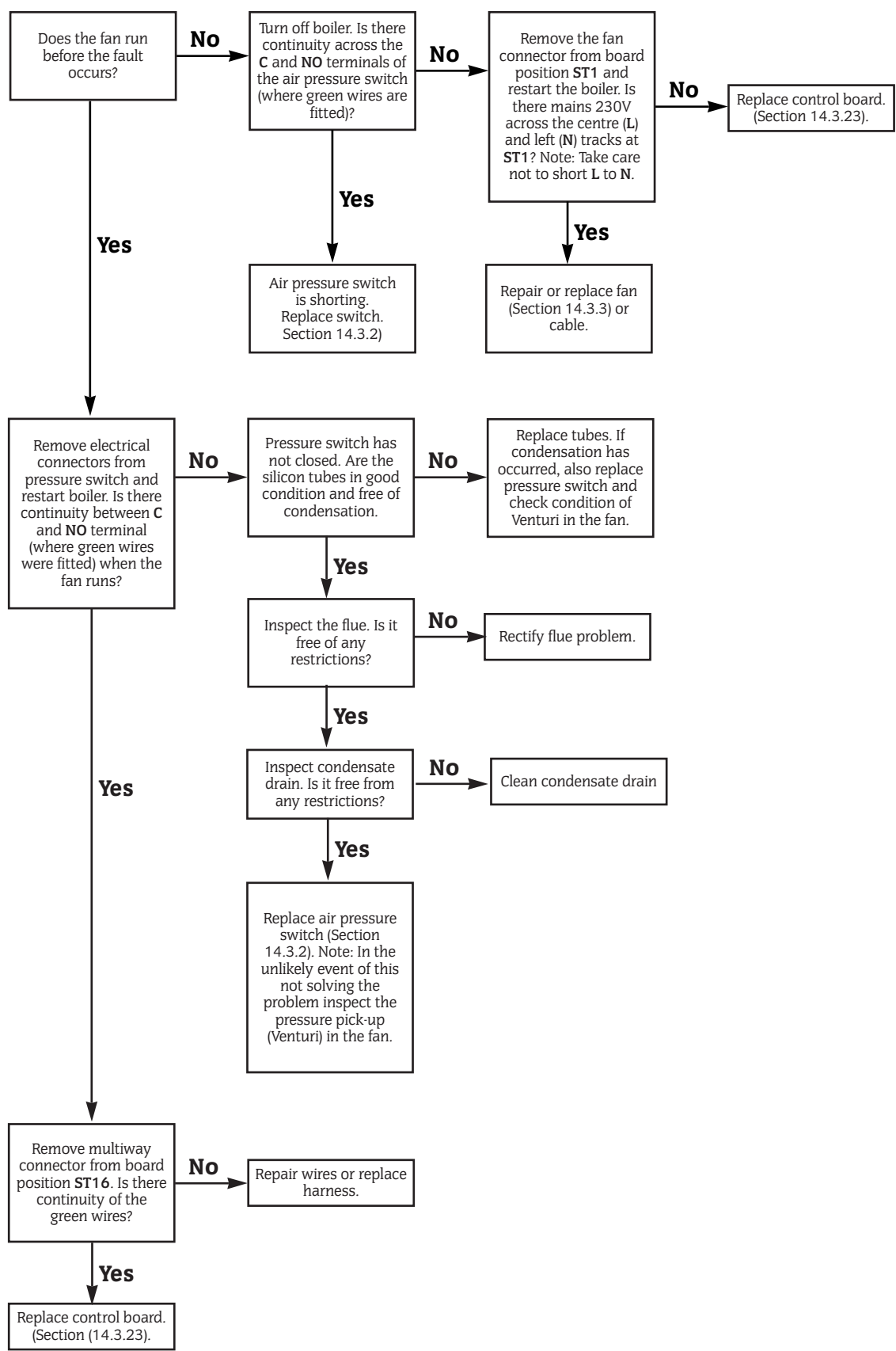

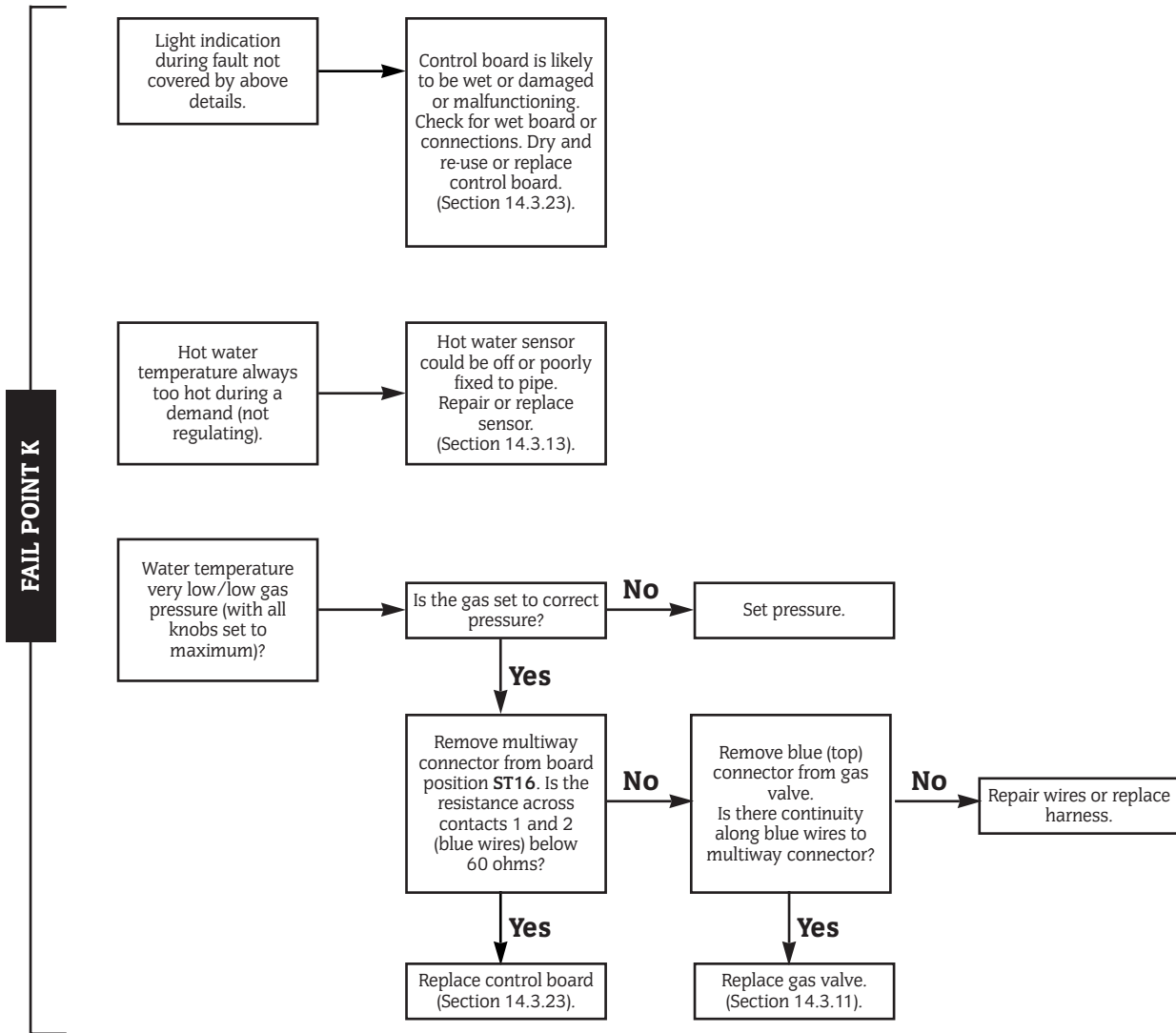



*Worcester Heat Systems Limited, Cotswold Way, Warndon, Worcester WR4 9SW.
Telephone: (01905) 754624. Fax: (01905) 754619.
Technical Helpline (0990) 266241*

This booklet is accurate at the date of printing but will be superseded and should be disregarded if specifications and/or appearances are changed in the interests of continued improvement.

All goods sold are subject to our official Conditions of Sale, a copy of which may be obtained on application.

PUBLICATION 8 716 145 159 Issue D 05/99