

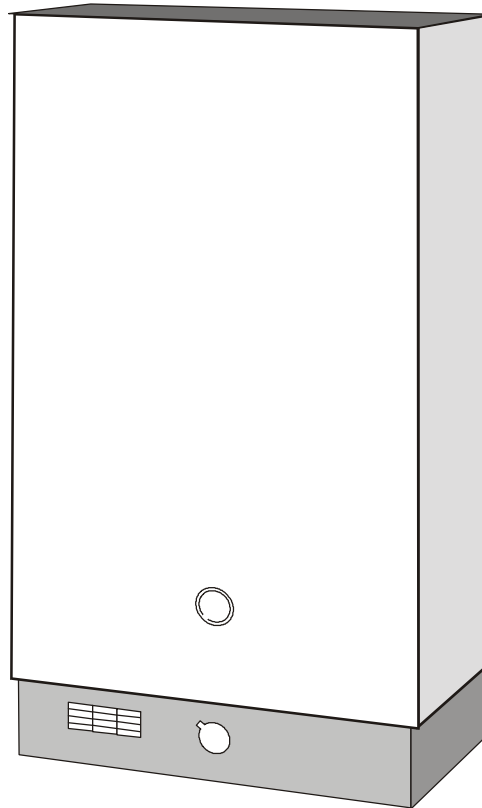

INSTALLATION AND SERVICE INSTRUCTIONS

Mersey Super Gas Fired Water Heater



MY95001A

G.C. NO.52476 38

NON SPOUTED MULTIPOINT MODEL

FOR USE WITH NATURAL GAS

THE GAS SAFETY (INSTALLATION AND USE) REGULATIONS 1984.

“In your own interest, and that of safety, it is law that all gas appliances are installed by competent persons, in accordance with the above regulations. Failure to install appliances correctly could lead to prosecution.”

Installation must be in accordance with the Building Regulations, Byelaws of the Water Undertaking, and I.E.E. Wiring Regulations. It should be in accordance also with any relevant requirements of the Local Gas Region and Local Authority and the relevant recommendations of the following British Standard Codes of practice: BS 6891, BS 5440:1:2 and BS 5546.

LEAVE THESE INSTRUCTIONS WITH THE USER FOR USE ON FUTURE CALLS

IMPORTANT
PLEASE READ THIS BOOK
BEFORE INSTALLING,
OPERATING OR
SERVICING THIS
APPLIANCE.



1. INTRODUCTION - Page 2

The Main Mersey Super is a room sealed instantaneous water heater designed to supply hot water to several outlets which may be situated in different rooms, but not necessarily at the same time.

The pilot is lit by a piezo spark igniter: no batteries or electricity are required. The main burners will automatically light when a domestic hot water tap is turned on and go out when the tap is turned off.

This appliance is not suitable for use with a swivel spout.

ENERGY CUT-OFF DEVICE

This appliance contains an Energy Cut-Off Device that will shut down the gas supply to the appliance if the water within the heat exchanger exceeds the anticipated temperature limit after the hot water tap has been turned off - See Page 21.

VENTILATION

Being a room sealed appliance, the Mersey Super does not require an air vent in the room or space in which it is installed. Where this appliance is installed in a compartment, air vents to the compartment at both high and low levels, should be provided for cooling.

Further guidance is given in BS 5440 Pt.2.

	Position of Air Vent	
	High	Low
In compartment which is ventilated to room	274 cm ² 42 in ²	274 cm ² 42 in ²
In compartment which is ventilated to outside	137 cm ² 21 in ²	137 cm ² 21 in ²

GENERAL

IMPORTANT: The area of wall covered by the appliance must be flat.

The clearances required around the Flue Terminal are shown on the Flue Template supplied with the Terminal Pack.

The appliance must be fitted on an external wall to allow the Flue Terminal to pass directly through the wall to the outside air.

If the appliance is to be installed into a "SEDUCT" the minimum duct required is 228mm (9in.) deep, 349mm (1 5/8in.) wide. This appliance may take the place of an existing appliance and will mount onto the original flue terminal of any of the following: AVON, BRISTOL, MEDINA, MEDINA D/L, MEDWAY, MERSEY, SEVERN 3, SEVERN 4, SEVERN 5 and TRENT.

2. TECHNICAL SPECIFICATIONS - Page 3

Finish	White stoved paint with contrasting chassis
Weight Packed	21.0 kg. (46.2 lb.)
Weight without Water	17.8 kg. (39.2 lb.)
Weight with Water	18.6 kg. (41.0 lb.)
Water Capacity	0.75 litre (0.17 gall.)
Input	30.3 kW (103,000 Btu/h.)
Maximum Output	22.7 kW (77,400 Btu/h.)
Flow Rates	6.5 l/mm at 50°C rise
Minimum pressure head requirement at water heater *	1 bar (14.6 psi) under flow conditions
Maximum pressure head	13 bar (189 psi)
Gas group	G 20
Burner injector (140ff)	1.2mm marking 120
Pilot injector	0.27mm marking A
Nominal burner pressure ** (maximum input)	12.5 mbar (5 in. w.g.)
Connections - Gas	15mm Copper Tail
- Water	15mm Compression
Balanced flues (telescopic) Wall thickness available	100mm - 150mm (4in - 6in) - Part No 31/1 0321 150mm - 230mm (6in - 9in) - Part No 31/1 0322 230mm - 380mm (9in - 15in) - Part No 31/1 0323 380mm - 610mm (15in - 24in) - Part No 31/1 0324
Flue Terminal Guard (Optional)	Part No 10/1 0262

Notes:

- * Additional external pipework and fittings may affect the resistance and must be taken into account on installation.
- ** The nominal burner pressure should be 12.5 mbar and will only be obtained if the appliance inlet pressure is correct at 20 mbar even when the appliance is running at full heat input. The meter should be capable of passing 1 00ft³/h of natural gas plus the requirements of any other gas appliances.

MINIMUM CLEARANCES

- Above 60mm
- Below 75mm
- Sides 5mm (Each)
- Front 220mm (To allow for removal of outer case)

For ease of servicing, allow as much clearance as possible below the appliance.

If the appliance is to be installed in a cupboard, the ventilation openings in the cupboard must NOT be blocked. DO NOT USE THE CUPBOARD FOR STORAGE.

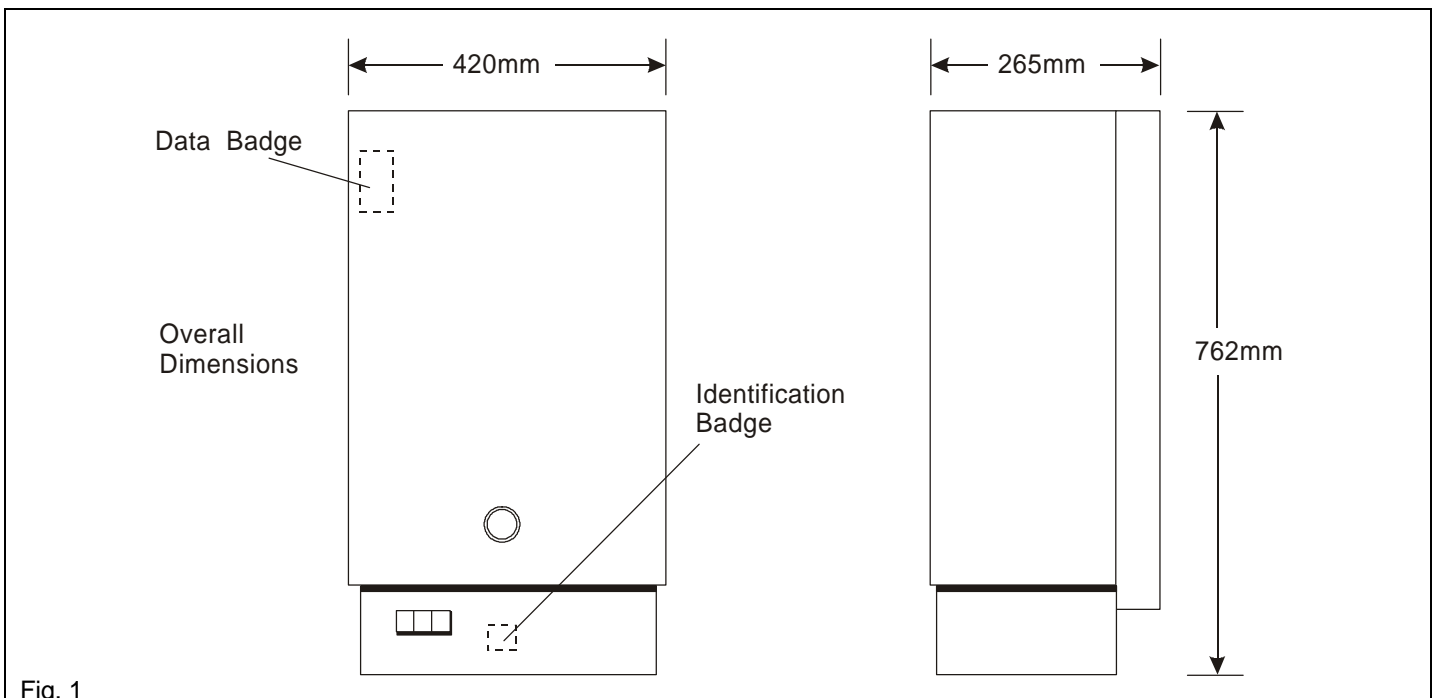
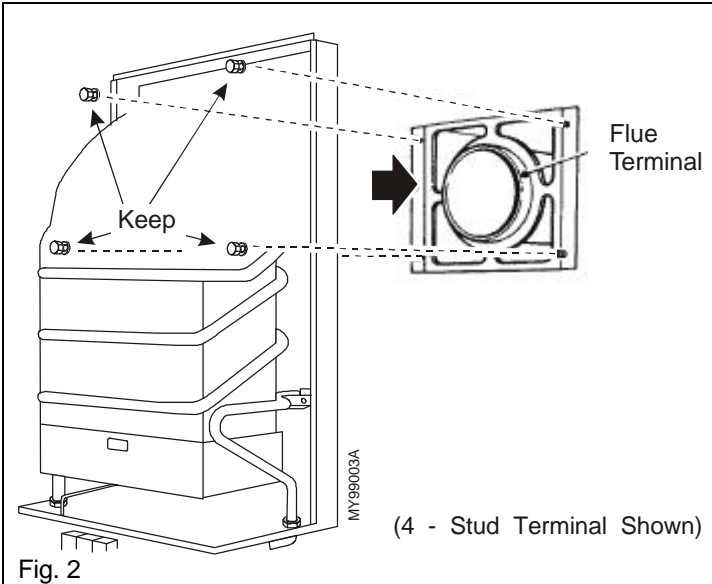

Fig. 1



A. LOCATION

1. If the appliance is to be fixed to a suitable existing terminal first isolate and remove the old appliance. Leave the flue terminal in place. Retain the fixing nuts and washers. Make good any damage to the brickwork or plaster around the terminal. Cut off the existing pipework at a convenient point below the appliance.
2. If installing a new flue terminal, guidance is given on the template sheet supplied with the terminal pack.

NOTE: Where the appliance is to be installed into a SEDUCT the minimum duct required is 228mm (9in) deep, 349mm (15 1/2in) wide.

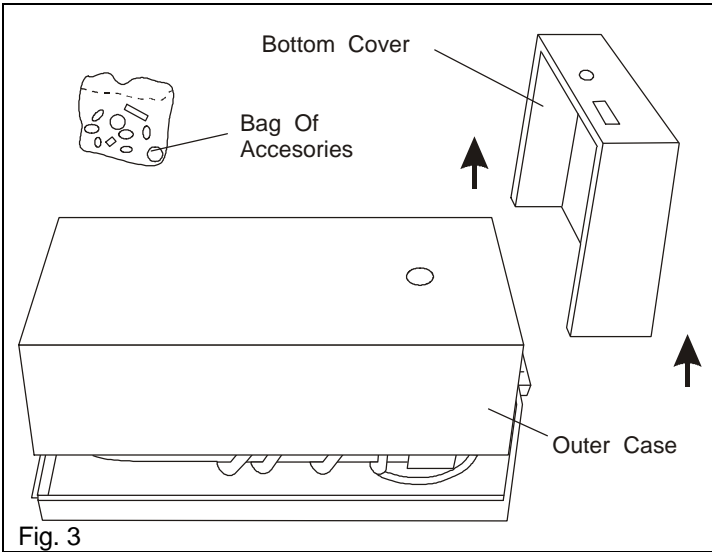

3. Where the building regulations require it, a flue terminal guard should be fitted symmetrically around the outer part of the flue terminal.
4. Unpack the water heater. Find the bags of accessories before discarding the packaging.
5. Slide off the bottom cover then remove the three screws securing the outer case and carefully lift it off.

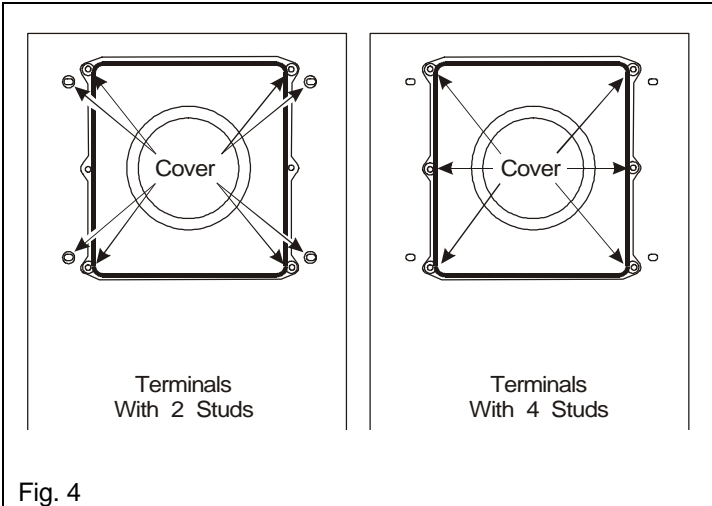

6. Use the self adhesive discs supplied to cover the unwanted fixing holes in the back of the new appliance as shown.

Fig. 4

7. Fit the flue terminal sealing strip (packed separately in the carton) into the recess around the flue aperture in the back of the appliance.
8. Lift the appliance into position, locating the flue outlet into the circular duct on the flue terminal.
9. Secure with the appropriate nuts and washers.

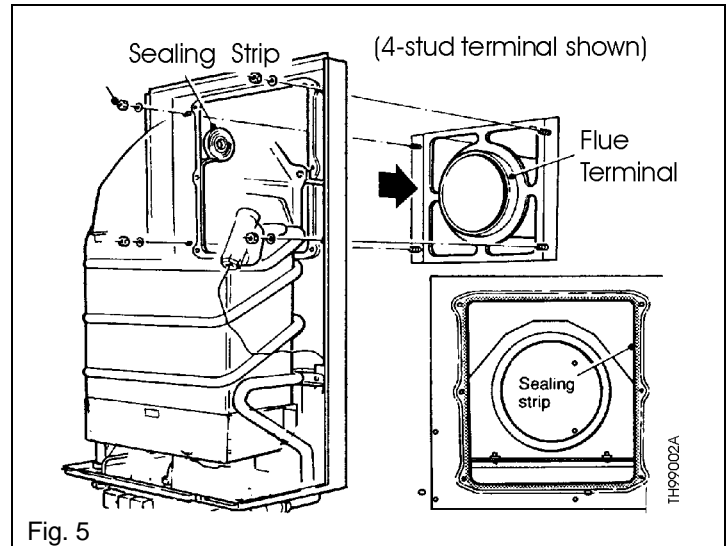

B. GAS CONNECTION

IMPORTANT: Blow out all foreign matter from the supply pipe before connecting to the gas service cock. 15mm copper pipe to BS 2871 may be used for a simple supply not exceeding 3 metres (10ft) from the gas meter. Where the installation contains many bends or the length is in excess of 3 metres (10ft), then the use of 22mm copper pipe is necessary.

1. Assemble the filter, 'O' ring and inlet tail to the gas inlet.
2. Depending on whether the main supply pipe is to be routed vertically or horizontally to the appliance, connect the gas service cock (stamped 'G') either directly to the gas inlet tail or within the supply pipe. **NOTE:** The service cock should be as close to the appliance as possible and the ON/OFF screw in an accessible position.
3. Ensure that the gas supply is turned OFF at the mains.
4. Connect to the gas supply.
5. Turn ON the gas supply and the gas service cock then test for gas soundness (BS 6891).

IMPORTANT: DO NOT TRY TO LIGHT THE APPLIANCE AT THIS STAGE. TO ALLOW THE MAIN BURNER TO IGNITE WITHOUT THE OUTER CASE SECURED IN POSITION IS A HAZARD.

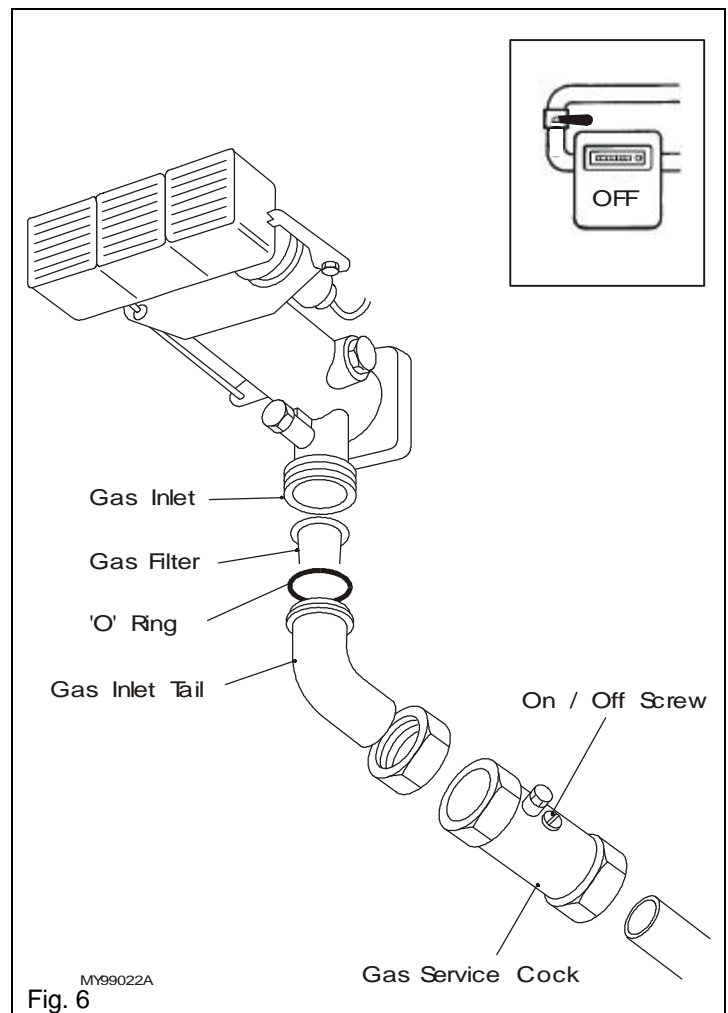

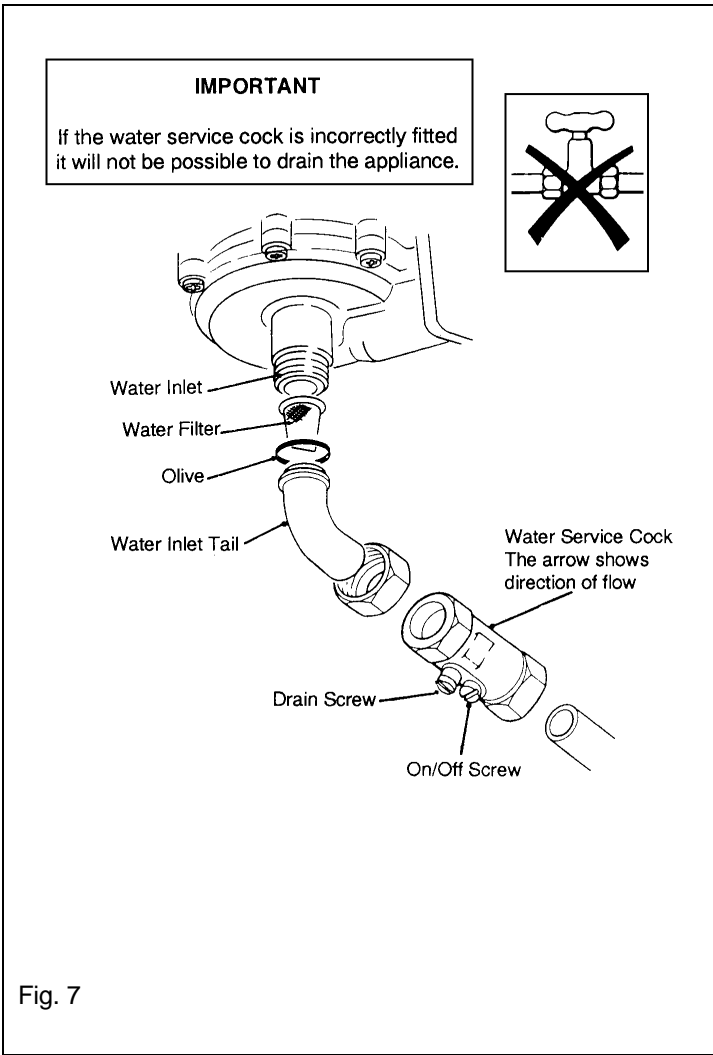

C. WATER CONNECTIONS

IMPORTANT: Flush out all foreign matter from the supply pipe before connecting to the service cock.

1. Assemble the filter, olive and inlet tail to the water inlet.
NOTE: The inlet tail need not be used as a vertical supply can be routed directly onto the water inlet.
2. Depending on whether the main supply pipe is to be routed vertically or horizontally to the appliance, connect the water service cock either directly to the water inlet tail or within the supply pipe. NOTE: The service cock should be as close to the appliance as possible and the ON/OFF screw in an accessible position.
3. Ensure that the mains water supply is turned OFF.

IMPORTANT: When routing the supply pipe to the appliance, ensure that it can be lowered by approx 25mm to allow for disconnection when servicing.

4. Connect the hot water supply pipes to the water outlet - 15mm compression.
5. Turn ON the mains water supply, turn ON the water service cock and open all the hot water outlets to allow water to flow. Purge the air from the system by closing the hot water outlets starting with the lowest level and ending with the outlet at the highest level.
6. Check for water leaks and remedy if found.

IMPORTANT: DO NOT TRY TO LIGHT THE APPLIANCE AT THIS STAGE.

D. LINT FILTER

This appliance has a lint filter fitted around the base of the pilot tube.

Ensure that the filter gauze is located inside both end caps and that the complete assembly is correctly seated over the union nut at the base of the pilot tube.

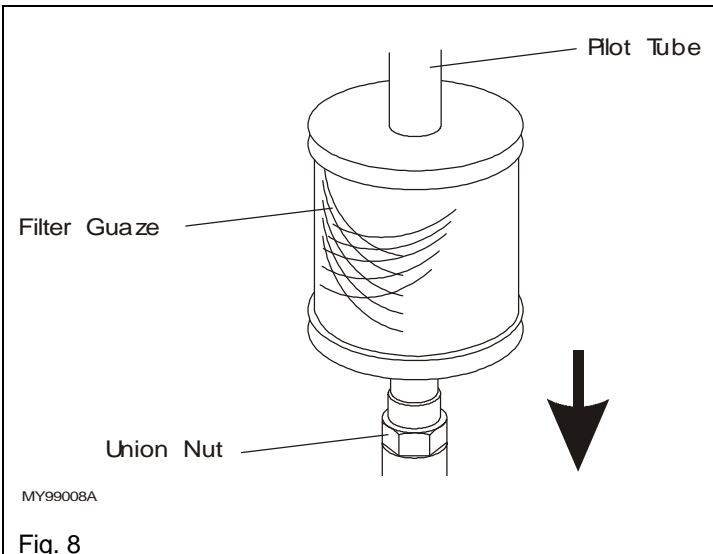

4. COMMISSIONING - Page 7



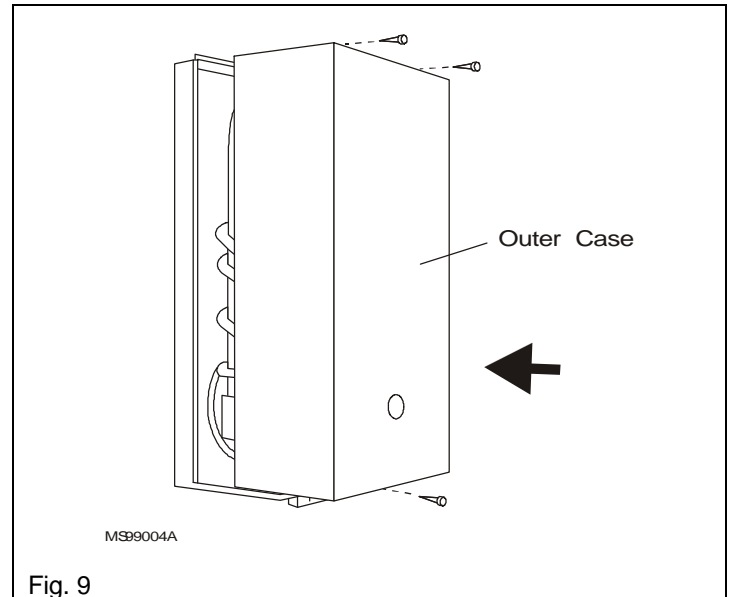

WARNING: The outer case of this appliance is not merely a cosmetic device. It is a functioning component in the air supply to the burner and **MUST BE** replaced with great care **NOW**, before any attempt is made to light the burners. **TO ALLOW THE MAIN BURNER TO IGNITE WITHOUT THE CASE IN POSITION IS A HAZARD.**

1. Refit the outer case ensuring it is correctly seated then secure (3 screws).

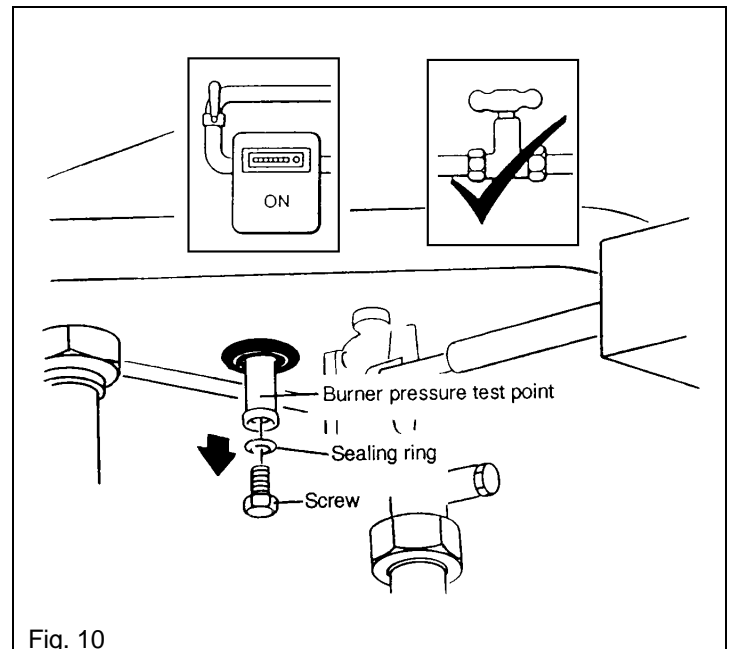

2. Ensure that the gas and water supplies are turned ON.
3. Ensure that all hot water outlets are closed.
4. Remove the screw and sealing ring from the burner pressure test point and attach a pressure gauge.



5. Fully depress and hold the ON button  and repeatedly press and release the IGN button  until the pilot is lit. The pilot flame can be observed through the pilot viewing window.
6. Hold the ON button  in for a further 10 seconds after the pilot is lit, then release. If the pilot goes out, repeat the lighting operation keeping the ON button  depressed a little longer.
7. Test for gas soundness using a suitable leak detection fluid on all external gas joints.
8. Open a hot water outlet and the burner will ignite. Allow the water to run for a few minutes then check the burner pressure - it should be 12.5 mbar (5 in w.g.), if the pressure is not correct see the **FAULT FINDING** section.

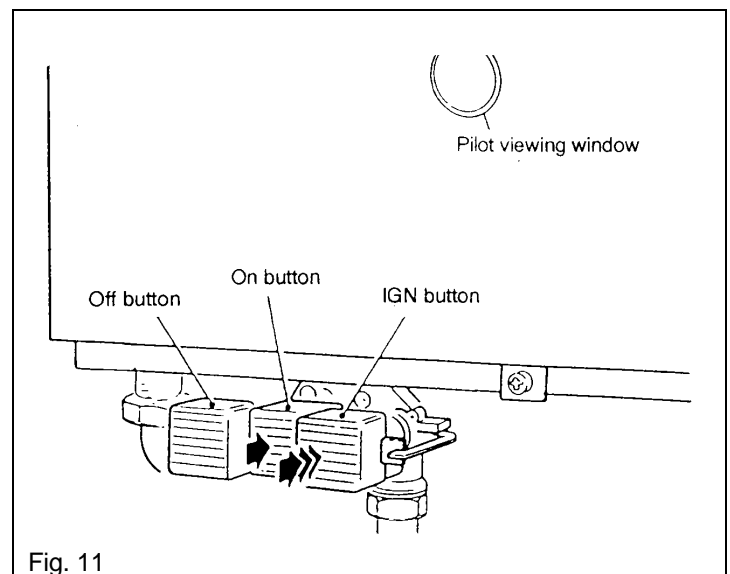

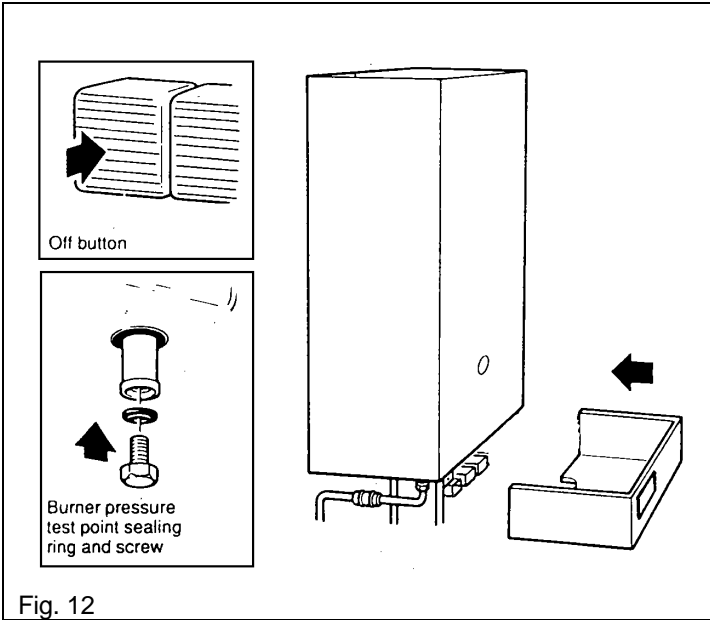

- NOTE: If a gas rate check is required, the gas consumption after 3 minutes running should be approximately 48.5 l/mm (1.7³/min).
9. Turn OFF the hot water outlet and press the OFF button '●' on the appliance. Remove the pressure gauge and replace the screw and sealing ring.
 10. Relight the pilot. Turn ON a hot water outlet and check for gas soundness at the pressure test point.
 11. Turn OFF the hot water outlet. Slide the bottom cover onto the appliance.

Fig. 12

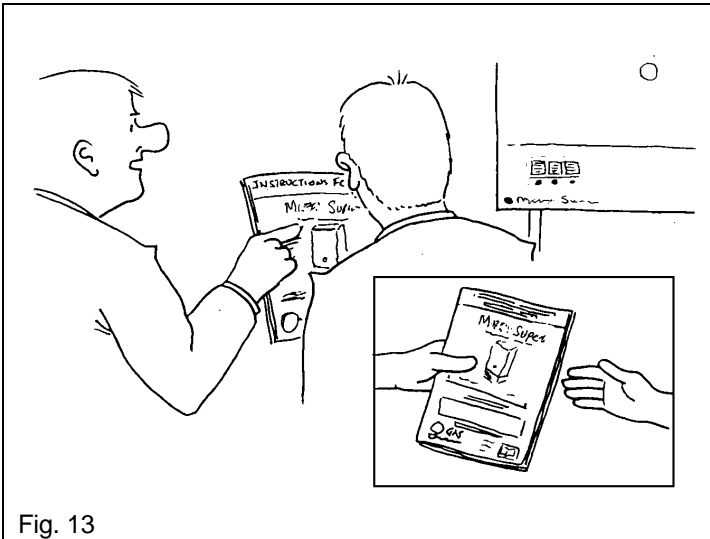

- Explain to the user how to operate the appliance.
- see the "Instructions for Use" booklet.
- Show the user the position of the Identification Badge.
- HAND OVER THE "INSTRUCTIONS FOR USE" TO THE USER.**
- LEAVE THESE "INSTALLATION AND SERVICE" INSTRUCTIONS WITH THE USER FOR USE ON FUTURE CALLS.**
- ADVISE THE USER THAT FOR CONTINUED EFFICIENT AND SAFE OPERATION OF THE APPLIANCE, IT IS IMPORTANT THAT SERVICING IS CARRIED OUT AT INTERVALS RECOMMENDED BY THE LOCAL BRITISH GAS REGION OR C.O.R.G.I. REGISTERED INSTALLER.**

Fig. 13

5. SERVICING - Page 8

To ensure continued efficient operation of the appliance, it is recommended that it is checked and serviced as necessary at regular intervals. The frequency of servicing will depend upon the particular installation conditions and usage, but in general once per year should be adequate.

IMPORTANT: It is the law that any service work must be carried out by competent persons such as British Gas or other c.o.r.g.i. registered personnel.

NOTE: In hard water areas, scale may build up on the push rod ,seals and on the underside of the diaphragm housing. They may require regular descaling and regreasing.

Operate the appliance noting any faults in the component units. Carry out the servicing procedure then correct any other faults by reference to 'Replacement of Parts', in which section you will find details of how to dismantle and reassemble the following detailed components. Check that the burner ignition is smooth and quiet when a hot tap is opened. The burner ignition has been factory set and should not need adjustment. However, if adjustment is required a slow ignition screw is fitted to the appliance and is situated above the cap screw in the water governor body (fig. 16). The screw is factory set 2 full turns out (anti-clockwise) from the fully in position. Turning the screw clockwise delays the ignition, anti-clockwise advances the ignition.

WARNING: NEVER OPERATE THIS APPLIANCE WITH THE OUTER CASE REMOVED.

1. Check the piezo unit, flame safety device and thermocouple, clean or replace if necessary.
2. Remove the burner assembly and clean using a soft brush or vacuum cleaner.
3. Check the pilot injector and clean or replace if necessary. Also clean the lint filter.
4. Remove the water governor assembly complete with push rod. Replace the seals if necessary. Descale and regrease the push rod, washers and diaphragm housing using Dow Corning 111 silicone grease.
5. Check for water and gas soundness. Replace 'O' rings, sealing washers and gaskets where required.
6. Clean any deposits off the heating unit by washing or brushing. Descale the heating unit if required.

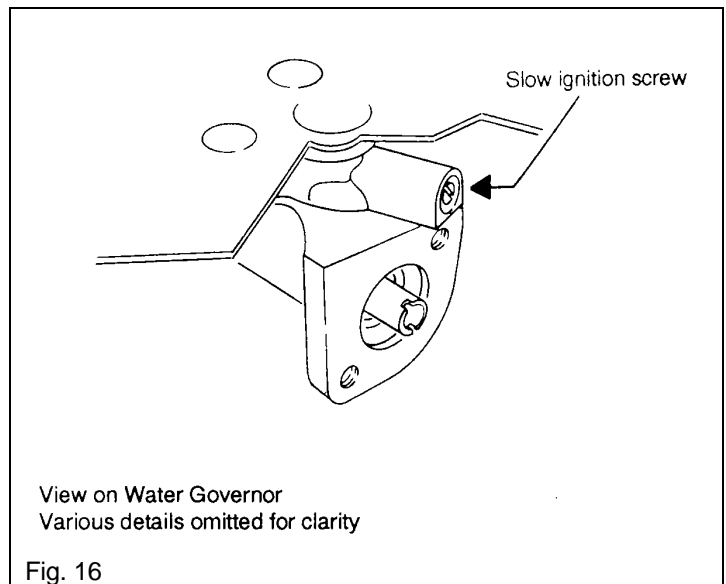
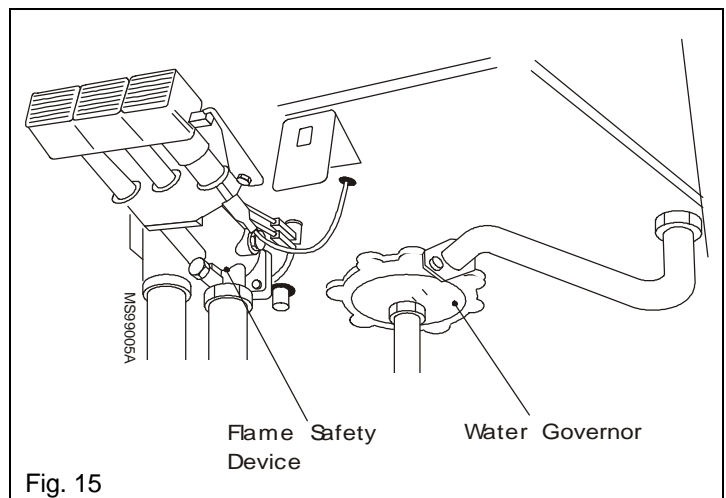
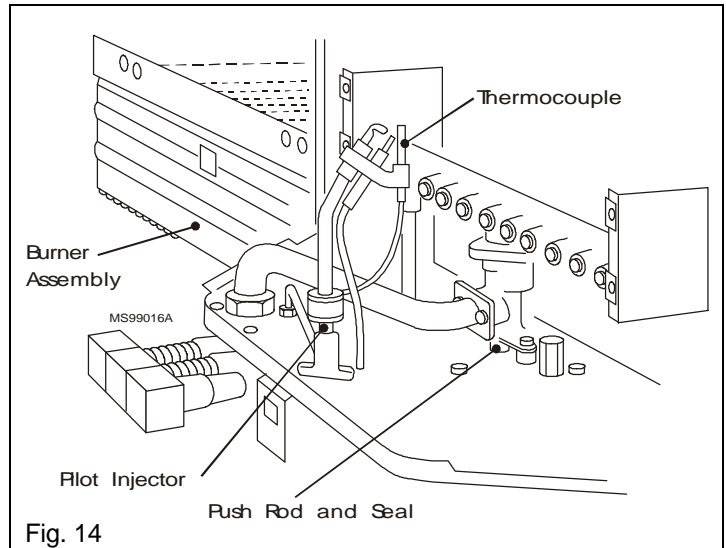

6. REPLACEMENT OF PARTS - Page 10

IMPORTANT: THE FOLLOWING WORK SHOULD ONLY BE CARRIED OUT BY A COMPETENT SERVICE ENGINEER. E.G. BRITISH GAS OR CORGI REGISTERED PERSONNEL

1. IF WATER IS DRAINED FROM THE SYSTEM DURING SERVICING, TURN ON ALL HOT TAPS TO PURGE AIR FROM THE WATER SYSTEM. TURN THEM OFF IN SEQUENCE, STARTING WITH THE TAP AT THE LOWEST LEVEL.
2. WHEN REPLACING ANY PARTS, RE-ASSEMBLE IN REVERSE ORDER UNLESS OTHERWISE STATED.

This chart shows the steps to be taken in order access a specific part or perform a particular function. Use this chart in conjunction with the detailed procedures on the following pages.

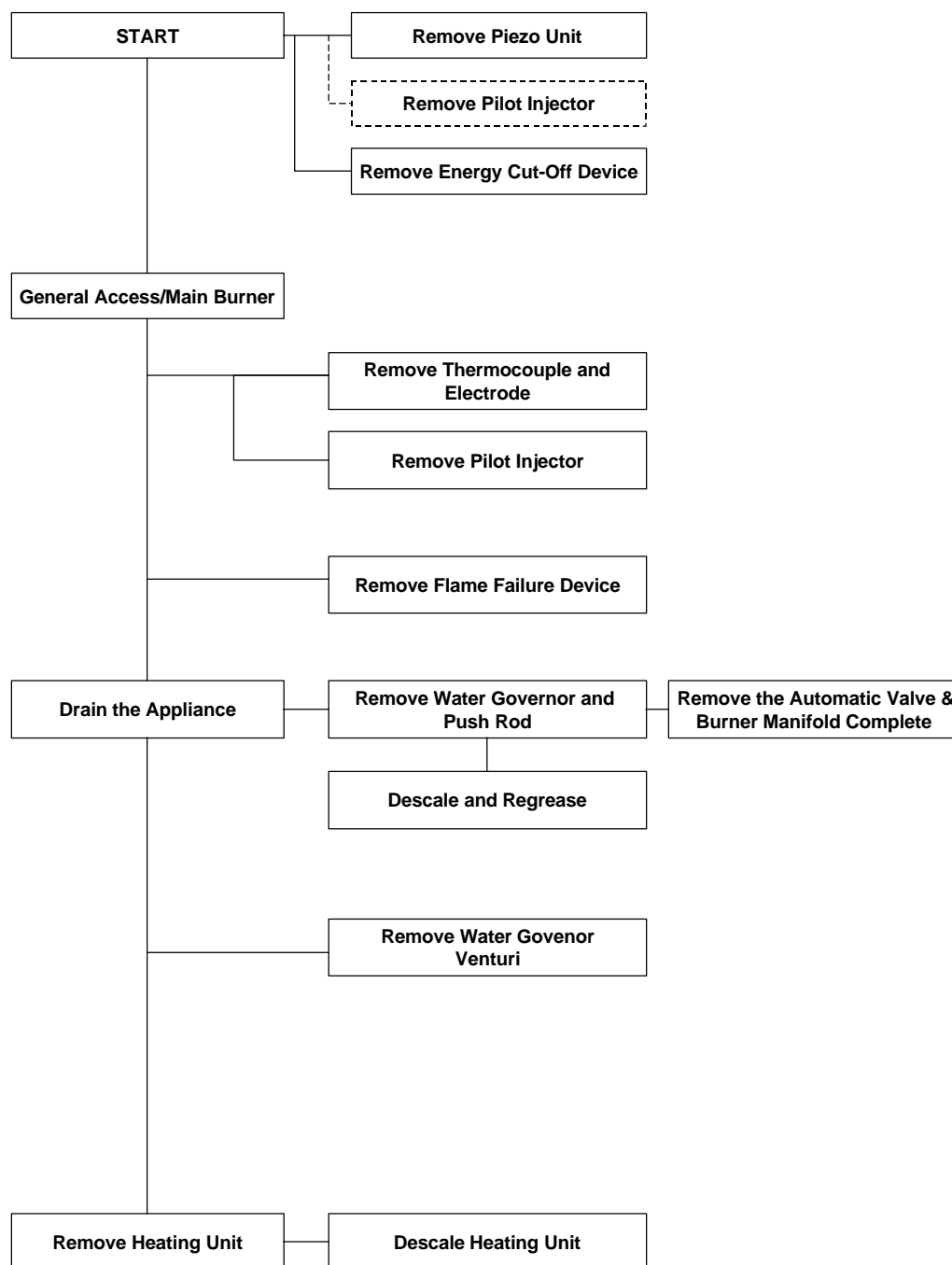

6.1. PIEZO UNIT

It will NOT be necessary to remove the outer case.

- a. Slide out the bottom cover.
- b. Disengage the electrode lead from the piezo unit.
- c. Remove or loosen and pull aside the spark button retainer, taking care not to lose the shakeproof washer.
- d. Pull off the button and unscrew (anti-clockwise) the piezo from its housing

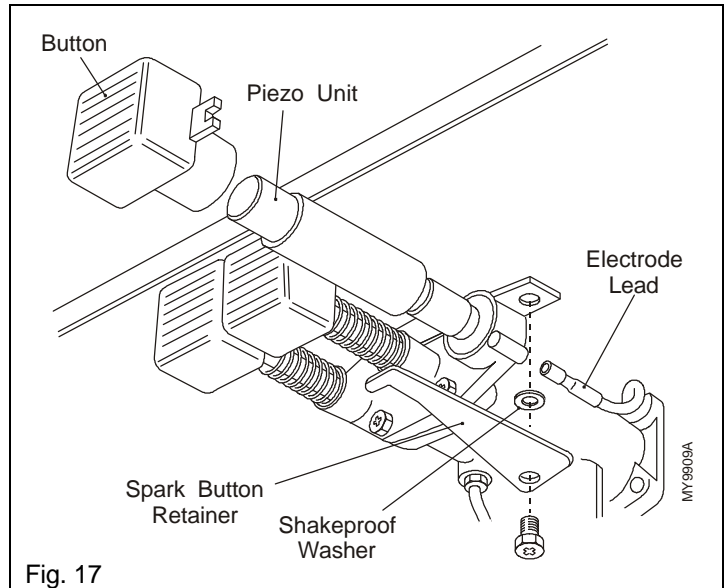

Fig. 17

6.2. GENERAL ACCESS/MAIN BURNER

- a. Turn OFF the gas and water supplies at the service cocks.
- b. Slide out the bottom cover.
- c. Remove the 3 fixing screws and pull off the outer case.

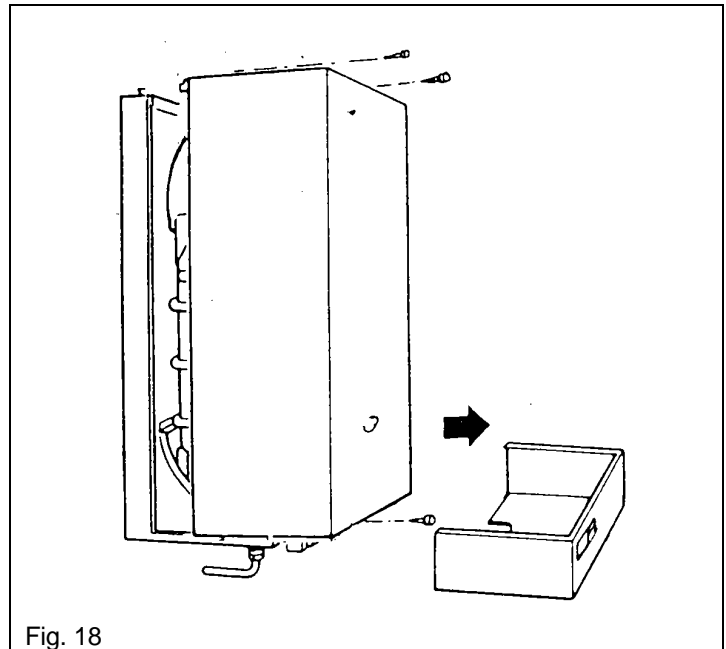

Fig. 18

- d. Remove 4 fixing screws from the burner assembly (2 each side).
- e. Remove 2 screws securing the front to the heating unit.
- f. Pull the burner assembly slightly forwards to clear the injectors, then pull apart and withdraw taking care not to snag the pilot assembly.

NOTE: If required, the burner assembly can be dismantled and the burner bars replaced individually. On re-assembly ensure that the burner inlets locate in the 14 holes.
 NOTE: On re-assembly of the burner assembly take care not to snag the pilot assembly. Ensure the front face of the assembly has located on the two studs on the heating unit.

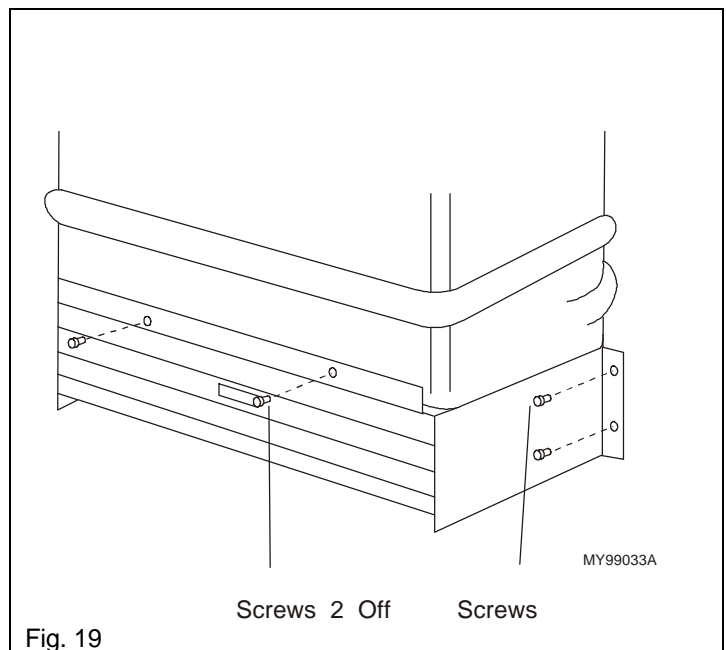
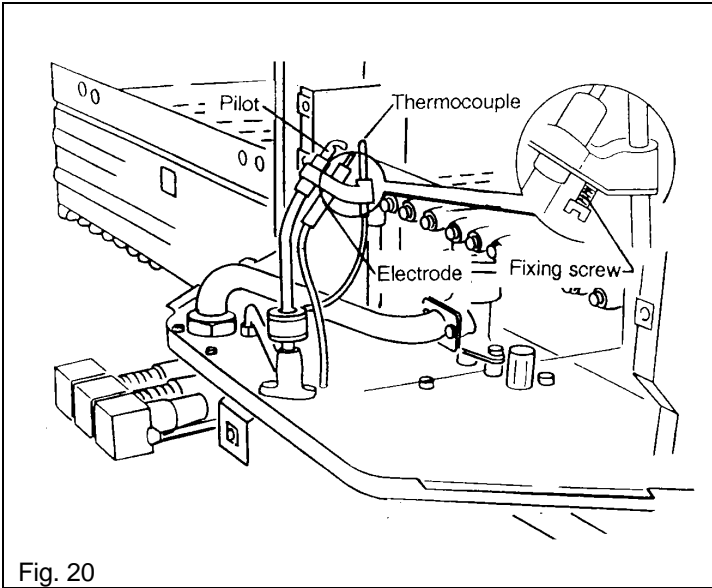

Fig. 19



6.3. THERMOCOUPLE AND SPARK ELECTRODE

- a. Gain general access - see 6.2.
- b. Remove the fixing screw and bracket then lower the spark electrode.
- c. Disconnect the nut securing the thermocouple to the interrupter at the chassis base.
- d. Disconnect the electrode lead from the back of the piezo unit, pull the lead up through the grommet and remove.
- e. On re-assembly, ensure that the pilot tube bends towards the rear of the appliance. (The thermocouple will be vertical and nearest the burner manifold).

Fig. 20

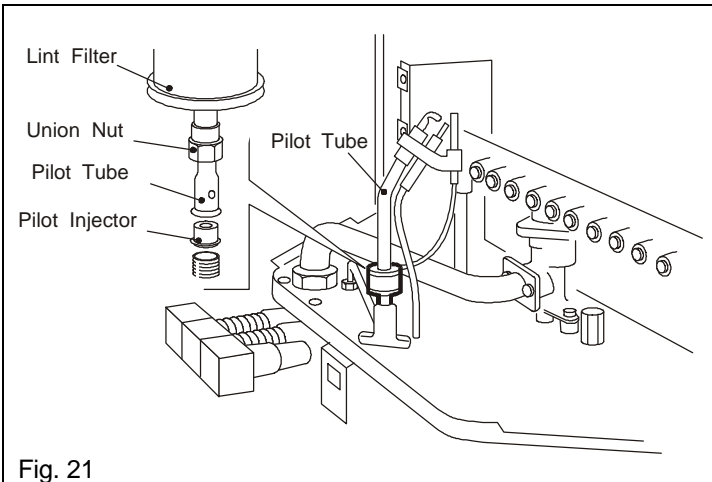

6.4. PILOT INJECTOR

- a. Gain general access - see 6.2.
 - b. Lift up the lint filter, disconnect the union nut and carefully lift up the pilot tube taking care not to lose the pilot injector.
 - c. On re-assembly ensure the pilot injector is correctly seated (taper side down) and that the lint filter is correctly assembled and located on the union nut.
- NOTE: The lint filter can be cleaned if required.

Fig. 21

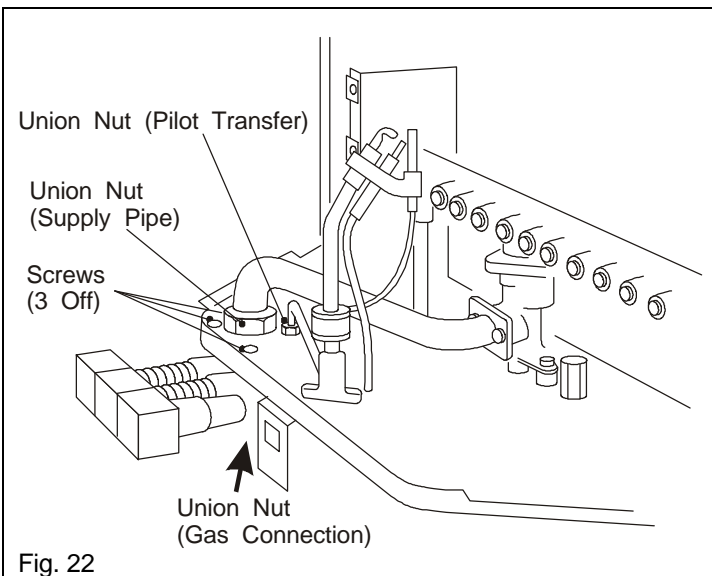

6.5. FLAME SAFETY DEVICE

- a. Gain general access - see 6.2.
- b. Disengage the electrode lead from the piezo unit.
- c. Release the thermocouple from the back of the flame safety device.
- d. Release the union nuts above and below the flame safety device.
- e. Release the union nut securing the pilot transfer tube to the flame safety device.
- f. Remove the 3 screws securing the flame safety device to the chassis base and carefully withdraw the unit.
- g. Re-assemble in reverse order.

Fig. 22

- h. Test for gas soundness as follows:-
 - Ensure the water service cock is in the OFF position. This will ensure water cannot flow and open the automatic valve.
 - Turn ON the gas, purge and light the pilot, this will pressurise the burner supply pipe.
 - Test the gas supply to flame safety device and burner supply pipe above the flame safety device for gas soundness using leak detection fluid.
- i. Re-assemble remaining parts and ensure the water service cock is in the ON position.

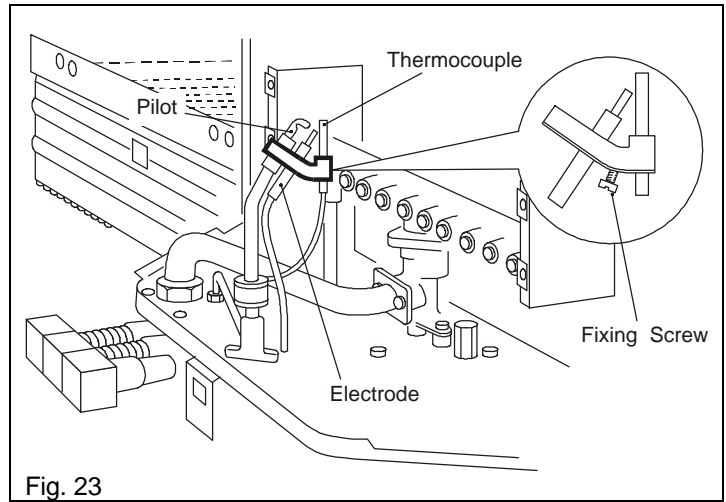

Fig. 23

6.6. TO DRAIN THE APPLIANCE

- a. Ensure that the gas and water service cocks are turned OFF.
- b. Open a hot water outlet.
- c. Have a suitable container to hand . Remove the drain screw from the water service cock and allow the water to drain.

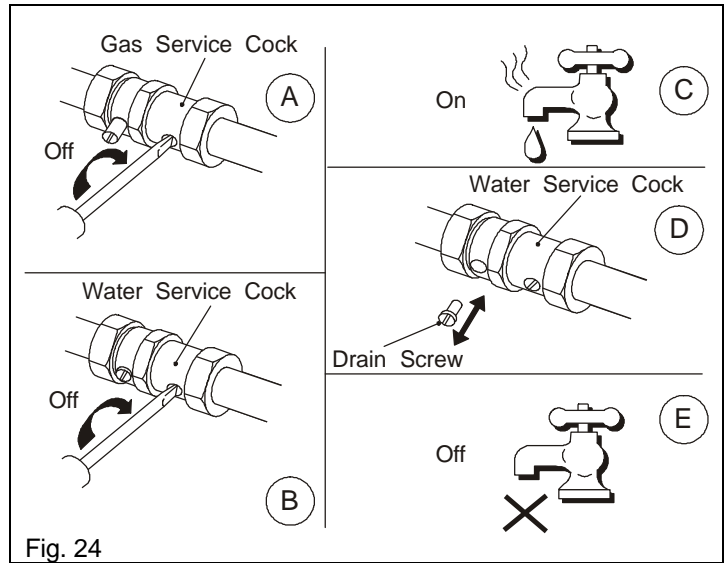

Fig. 24

6.7. WATER GOVERNOR

- a. Gain general access - see 6.2.
- b. Drain the appliance - see 6.6.
- c. Release the inlet water connection and lower the pipework to clear the inlet.
- d. Release the union nut and clamping plate then remove the feed pipe. Replace the 'O' ring.

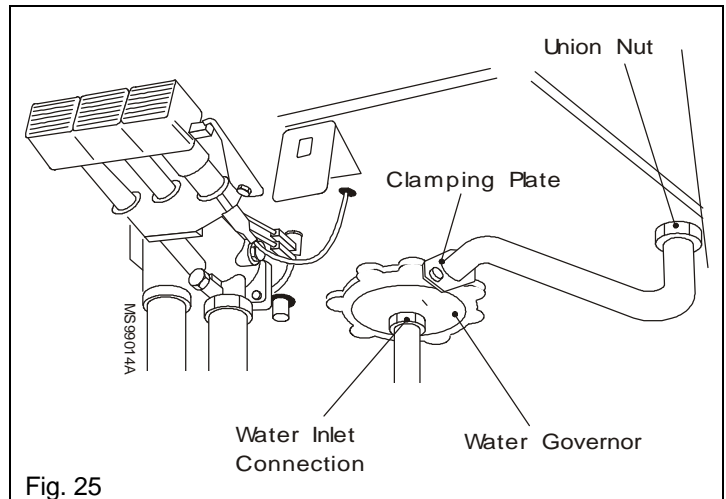
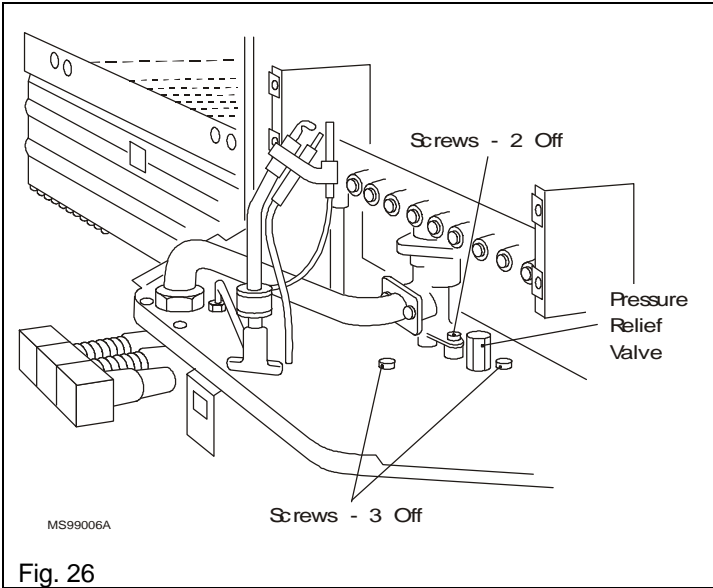
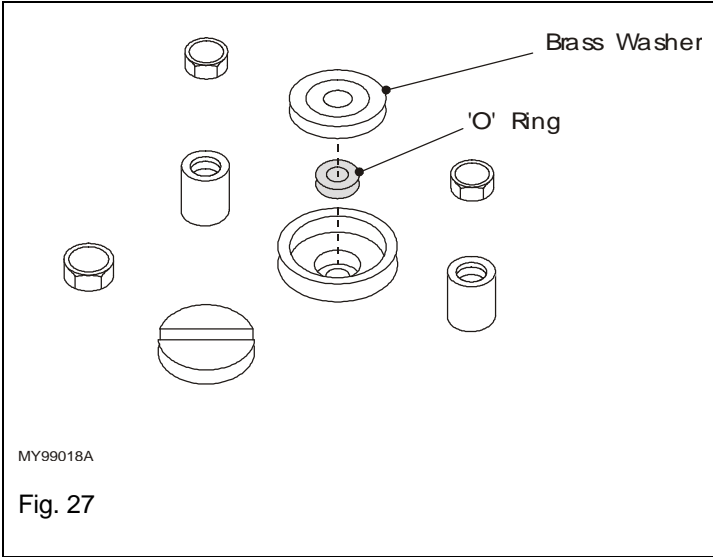

Fig. 25



- e. Remove 2 screws above the chassis base securing the governor to the automatic valve.
- f. Remove 3 screws above the chassis base securing the governor to the chassis base.
- g. Carefully withdraw the governor complete with pressure relief valve, TAKE CARE NOT TO BEND THE PUSH ROD. IF THE ROD IS BENT, A NEW ONE MUST BE FITTED.
- h. Remove the push rod.
- i. Remove 6 screws and separate the two halves of the water governor.

DESCALE AND REGREASE



- j. Remove both the brass washer and 'O' ring from the top opening. Clean the washer.
- k. Clean the top opening then pack with a silicone grease such as Dow Corning 111. Fit a new 'O' ring and re-fit the brass washer.
- l. Hold the thrust plate, remove the fixing nut and lift out the diaphragm assembly. Clean or renew as required. On re-assembly, tighten the fixing nut finger tight plus a 1/4 turn only.
- m. Check and if necessary replace the transfer port 'O' ring.
- n. Ensure the diaphragm assembly is correctly seated then re-assemble the two halves of the governor. Insert the 6 screws and secure finger tight. Fully tighten all 6 screws in the order shown.
- o. Clean, regrease and re-fit the push rod or replace with a new one.

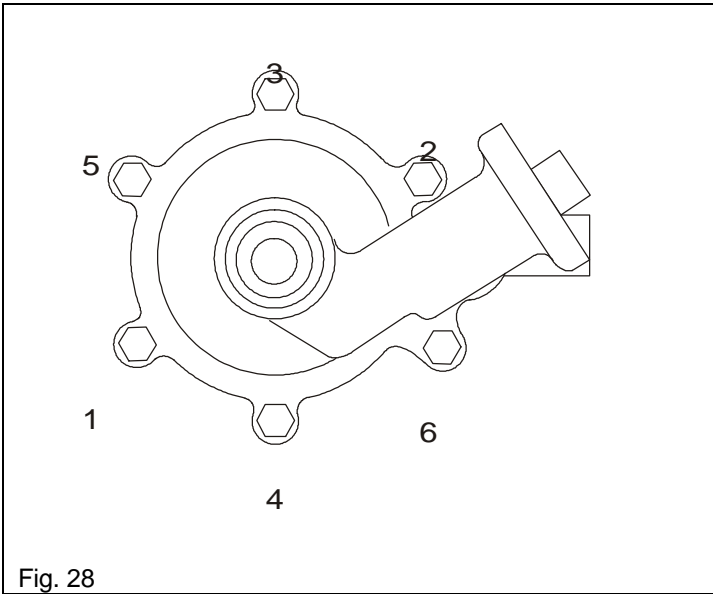
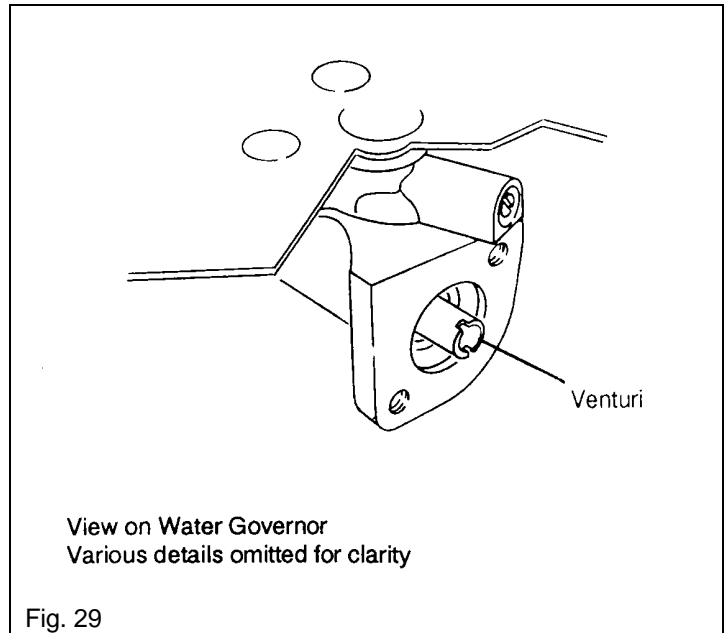

Fig. 28

6.8. WATER GOVERNOR VENTURI

- a. Gain general access - see 6.2.
- b. Drain the appliance - see 6.6.
- c. Release the union nut and clamping plate then remove the feed pipe.
- d. Using a large flat bladed screwdriver that will engage both slots, remove the venturi.
- e. Clean and re-fit.



6.9. AUTOMATIC VALVE AND BURNER MANIFOLD COMPLETE

- a. Gain general access - see 6.2.
- b. Drain the appliance - see 6.6.
- c. Remove the water governor - see 6.7.
- d. Release the union above the flame safety device. Do not lose the 'O' ring.
- e. Release the retaining plate (2 screws) and remove the burner supply pipe. Do not lose the 'O' ring.
- f. Prise the manifold location brackets apart and carefully lift out the complete assembly.

IMPORTANT: The automatic valve and burner manifold are only available as a combined assembly. Retain all screws and 'O' rings from the old assembly or renew.

NOTE: On re-assembly slide the pressure test point extension tube through the grommet before locating the manifold against the location brackets.

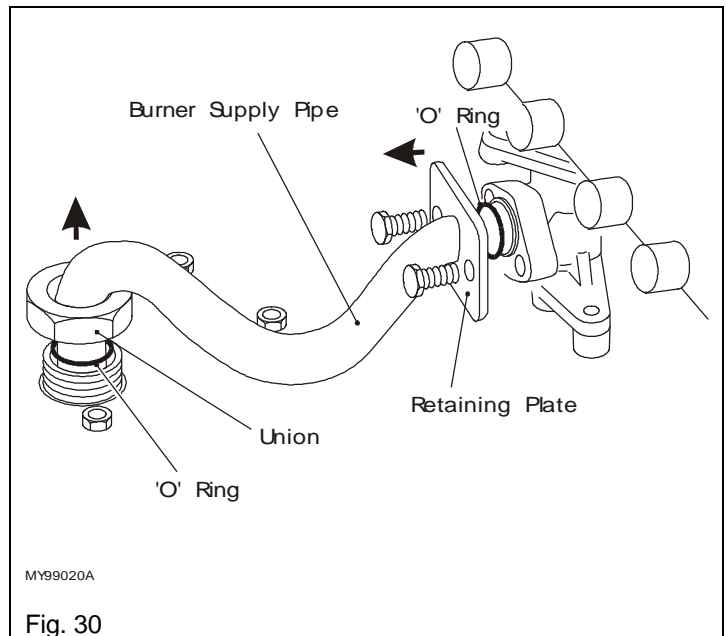

- g. Re-fit the water governor.
- h. Re-connect the burner supply pipe.
- i. Test for gas soundness as follows:-
 - Ensure the water service cock is in the OFF position, this will ensure that water CANNOT flow and open the automatic valve.
 - Turn ON the gas, purge and light the pilot, this will pressurise the burner supply pipe.
 - Test the burner supply pipe joints for gas soundness using leak detection fluid.
- j. Re-assemble remaining parts and ensure the water service cock is in the ON position.

IMPORTANT: If the automatic valve and burner manifold complete is dismantled, it can only be tested for gas soundness under pressure AFTER blanking off all the injectors.

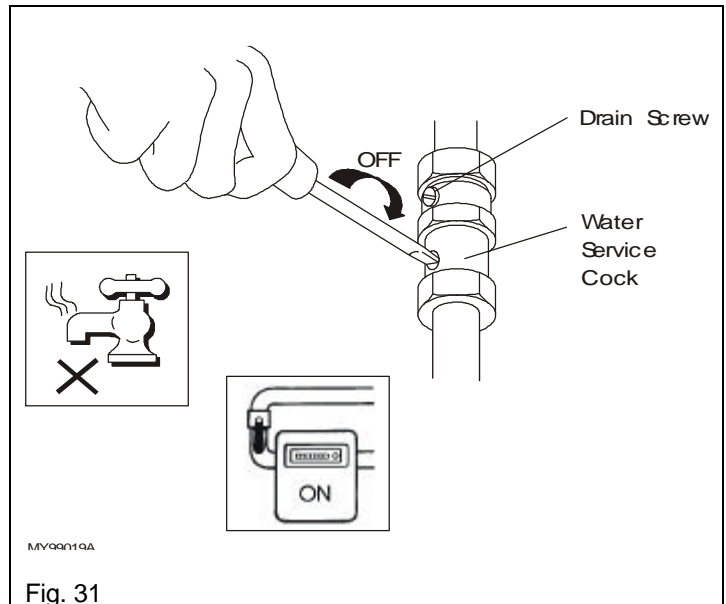

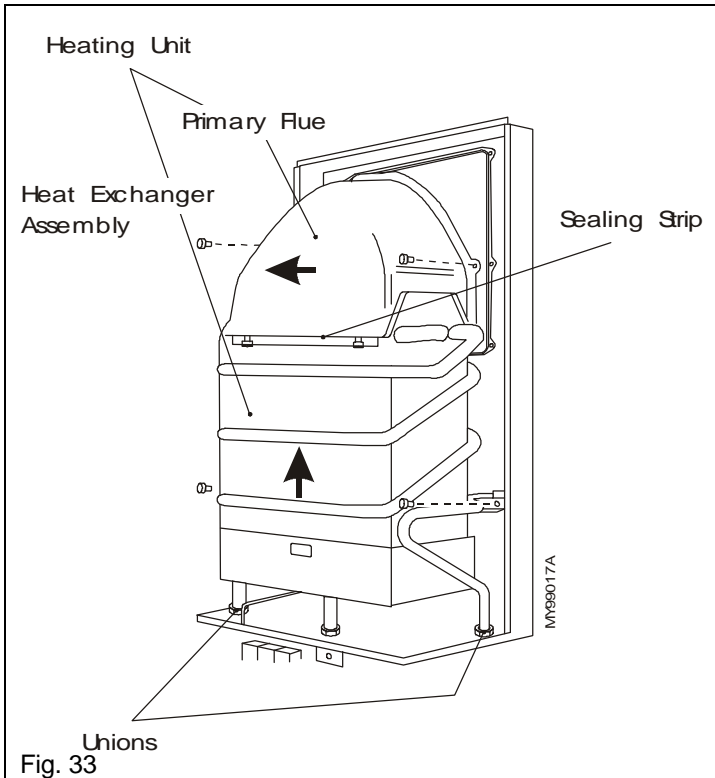

6.10. HEATING UNIT

- a. Gain general access - see 6.2.
- b. Drain the appliance - see 6.6.
- c. Remove the 2 screws securing the energy cut-off device to the heating unit (located top front left).
- d. Disconnect the 2 unions.
- e. Remove 4 screws securing the unit to the chassis.
- f. Carefully pull the unit from the top and lift. DO NOT lose the 'O' rings and washers.
- g. Remove the primary flue, secured by 4 screws (2 front, 2 rear).

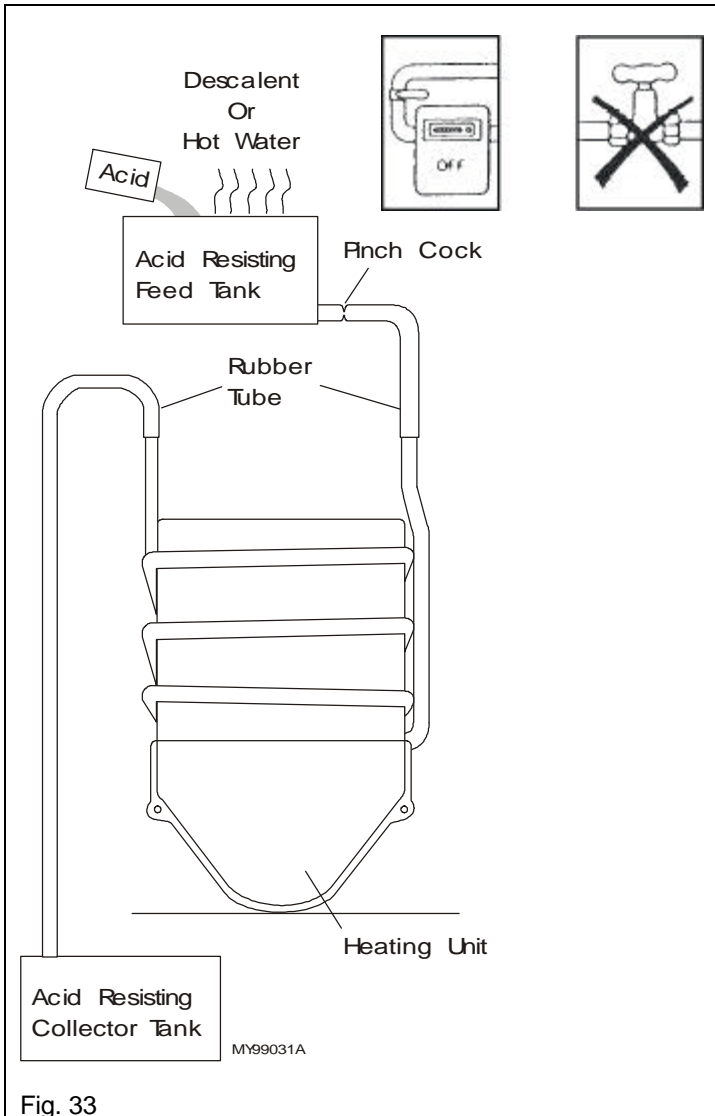

6.11. DESCALING THE HEATING UNIT

WARNING: ACID/WATER SOLUTION MUST BE USED WITH EXTREME CAUTION. TAKE CARE NOT TO SPLASH ONTO SKIN OR INTO THE EYES. WASH ANY AFFECTED AREAS WITH LARGE AMOUNTS OF COLD WATER AND SEEK MEDICAL ADVICE. CARRY OUT THE FOLLOWING OPERATION OUT OF DOORS. ACID/WATER SOLUTION CAN DAMAGE FURNISHINGS ETC.

- a. Gain general access - see 6.2.
- b. Drain the appliance - see 6.6.
- c. Remove the heating unit - see 6.10.
- d. Invert the heating unit on a suitable bench or table.
- e. Using rubber tube and acid resisting tanks, assemble as shown in fig.33.
- f. Fill the upper container with a proprietary brand of descalent or a solution of 10 parts water to 1 part hydrochloric acid. The water should preferably be hot, then add ACID to WATER, not water to acid.
- g. Adjust the pinch cock and allow the fluid to slowly pass through the heating unit into the collecting tank.
- h. Continue the process until the fluid ceases to bubble. It may be necessary to replenish the solution.
- i. Disconnect and thoroughly wash out the heating unit with clean water.

6.12. PILOT VIEWING GLASS AND SEAL

- a. Complete steps a., b. and c. of section 6.2.
- b. The viewing glass and seal are fixed to the inside of the outer case by 2 metal tabs. Bend back the tabs and remove the glass and seal. Secure the new glass and seal to the outer case by bending over the 2 spare straight tabs.

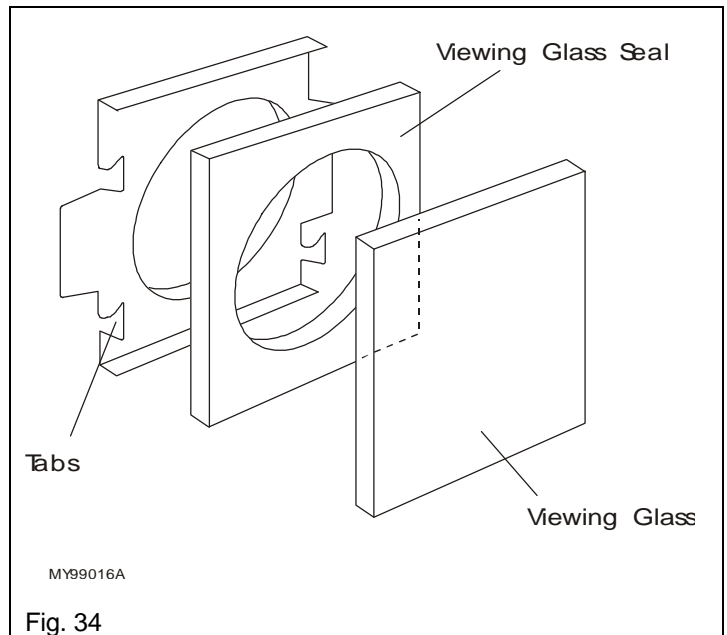

6.13. ENERGY CUT-OFF DEVICE

- a. Gain general access - see 6.2.
- b. Disconnect the energy cut-off leads from the interrupter located on the underside of the chassis.
- c. Remove the 2 screws securing the energy cut-off device to the heating unit (located top front left).
- d. Pull the leads complete with grommets up through the chassis base.
- e. Fit the new energy cut-off device which comes complete with grommets.

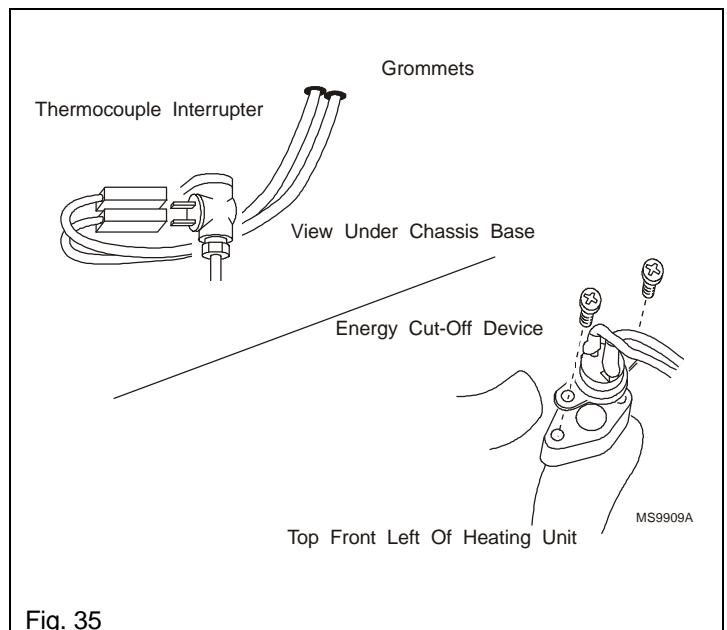

7. FAULT FINDING - Page 18

SYMPTON	POSSIBLE CAUSE	SOLUTION
PILOT WILL NOT LIGHT	1. Gas not turned on.	1. Turn on the gas at the gas service cock and/or the main gas line.
	2. Air in gas line.	2. Purge the air line by depressing and holding the centre ON button, this may take 2-3 minutes.
	3. Incorrect pilot lighting procedure.	3. Follow the lighting instructions located on the bottom cover or refer to the "Instructions for Use".
	4. Electrode lead not connected to the rear of the spark igniter.	4. Re-connect the electrode lead.
	5. Incorrect spark gap.	5. The gap between the electrode tip and the pilot hood should be 3-4mm.
	6. Current tracking to earth.	6. Check the electrode lead is routed clear of all metal parts.
	7. Pilot injector blocked.	7. Clear injector by blowing through or replace with pilot injector Part No 19/12690. Also clean the lint filter located at the base of pilot tube.
	8. Faulty components.	8. Replace any faulty components found. Piezo Unit - Part No 10/11935. Electrode Assembly - Part No 10/17493.
	9. No gas to the appliance.	9. Call in your local British Gas Region.
PILOT LIGHTS BUT WILL NOT REMAIN ALIGHT	1. Thermocouple connections loose.	1. Tighten the connections.
	2. Pilot flame soft' or too small to heat the thermocouple tip.	2. Pilot injector partially blocked, clear by blowing through or replace. Check the gas inlet pressure is correct - 20 mbar. Also clean the lint filter located at the base of the pilot tube.
	3. Thermocouple worn out or damaged.	3. Replace the thermocouple - Part No 10/17461.
	4. Faulty magnet unit in the flame safety device.	4. Replace flame safety device- Part No 10/13477.
	5. Energy cut-off device connections loose.	5. Tighten connections.
	6. Energy cut-off device may be faulty.	6. Check for continuity and replace if necessary - Part No 10/17792.

SYMPTON	POSSIBLE CAUSE	SOLUTION
PILOT LIT BUT MAIN BURNER WILL NOT LIGHT ON WATER FLOW	<ol style="list-style-type: none"> 1. Gas inlet pressure low. 2. Low water flow caused by blocked water filter. 3. Faulty diaphragm. Will also cause a high water rate 4. Automatic gas valve push rod jammed. May also cause a high water rate. 5. Slow ignition screw incorrectly set. Will also cause a high water rate. 	<ol style="list-style-type: none"> 1. Call in your local British Gas Region 2. Clean the debris from the filter. 3. Replace the Diaphragm Assembly - Part No 10/17572. 4. Dismantle clean and regrease using Dow Corning 111 silicone grease. Handle the push rod with care, do not bend. 5. See Fig. 16 for the position of the screw. Turning the screw clockwise delays the ignition, anti-clockwise advances the ignition. The screw should be set 2 full turns out (anti clockwise) from the fully in position. When correct the burner ignition should be smooth and quiet when a hot water outlet is opened.
NO OR LOW WATER FLOW RATE	<ol style="list-style-type: none"> 1. Blocked water filter. 2. Heat exchanger blocked with lime. 3. Loss of service water main pressure. 	<ol style="list-style-type: none"> 1. Clean the debris from the filter. 2. Descale or replace - Part No 10/17558. 3. Contact your Local Water Authority.
HIGH WATER FLOW RATE	See LOW WATER TEMPERATURE	
HIGH WATER TEMPERATURE	<ol style="list-style-type: none"> 1. Automatic gas valve push rod sticking. Water rate will be normal. 	<ol style="list-style-type: none"> 1. Dismantle clean and regrease using Dow Corning 111 silicone grease. Handle the push rod with care, do not bend.

SYMPTOM	POSSIBLE CAUSE	SOLUTION
LOW WATER TEMPERATURE	<ol style="list-style-type: none"> 1. Gas pressure too low. 2. Faulty diaphragm. Will also cause a high water rate. 3. Automatic gas valve push rod sticking. May also cause a high water rate 4. Slow ignition screw incorrectly set. Will also cause a high water rate. 	<ol style="list-style-type: none"> 1. Check and clean gas filter, also check gas inlet pressure. 2. Replace the Diaphragm Assembly - Part No 10/17572. 3. Dismantle clean and regrease using Dow Corning 111 silicone grease. Handle the push rod with care, do not bend. 4. See Fig.16 for the position of the screw. Turning the screw clockwise delays the ignition, anti-clockwise advances the ignition. The screw should be set 2 full turns out (anti clockwise) from the fully in position. When correct the burner ignition should be smooth and quiet when a hot water outlet is opened.
NOISY HEATER	<ol style="list-style-type: none"> 1. Heat exchanger scaled. Ultimately this will cause the heat exchanger fins to discolour and buckle. 2. Noisy ignition could be caused by incorrect setting of the slow ignition screw. 3. Reduced pilot rate caused by dirt. 4. Burner aeration ports and main flame ports blocked. 	<ol style="list-style-type: none"> 1. Descale or replace - Part No 10/17558. 2. See Fig. 16 for the position of the screw. Turning the screw clockwise delays the ignition, anti-clockwise advances the ignition. The screw should be set 2 full turns out (anti-clockwise) from the fully in position. When correct the burner ignition should be smooth and quiet when a hot water outlet is opened. 3. Clear injector by blowing through or replace with pilot injector Part No 19/12690. Also clean the lint filter located at the base of pilot tube. 4. Carefully clean the burners with a vacuum cleaner.

SYMPTOM	POSSIBLE CAUSE	SOLUTION
SMELL OF COMBUSTION PRODUCTS	1. Faulty case or terminal seal.	1. Check that the outer case seal - Part No 10/17501 and terminal seal - Part No 31/12299 are in good condition, replace if necessary. Ensure the outer case is correctly positioned.
	2. Failure to follow Instructions with regards to openable windows and doors.	2. Re-site the appliance.

SYMPTOM

UNEXPLAINED SHUT-DOWN OF THE APPLIANCE

This appliance contains an Energy Cut-Off Device which reacts when the water in the heat exchanger exceeds the anticipated temperature limit. Although it is intended to guard against failure of the automatic gas valve, it may be triggered inadvertently by other causes, especially during the summer months when the inlet water temperature is unusually high.

However, if the energy cut-off device reacts to a slowly closing automatic gas valve, the shut down of the appliance may be accompanied by noises from the heat exchanger and pipework. The pressure relief valve located on top of the water governor may also have vented water into the case. In this situation it is possible that STEAM will come out of the hot water tap when turned on.

POSSIBLE CAUSE	SOLUTION
Excessive resistance of push rod.	Exchange push rod and seals. Lubricate with Dow Corning III silicone grease and ensure free movement.

IMPORTANT NOTE

To ensure continued safe operation, we recommend that if the pressure relief valve has operated, it should be replaced immediately

8. SHORT SPARE PARTS LIST - Page 22

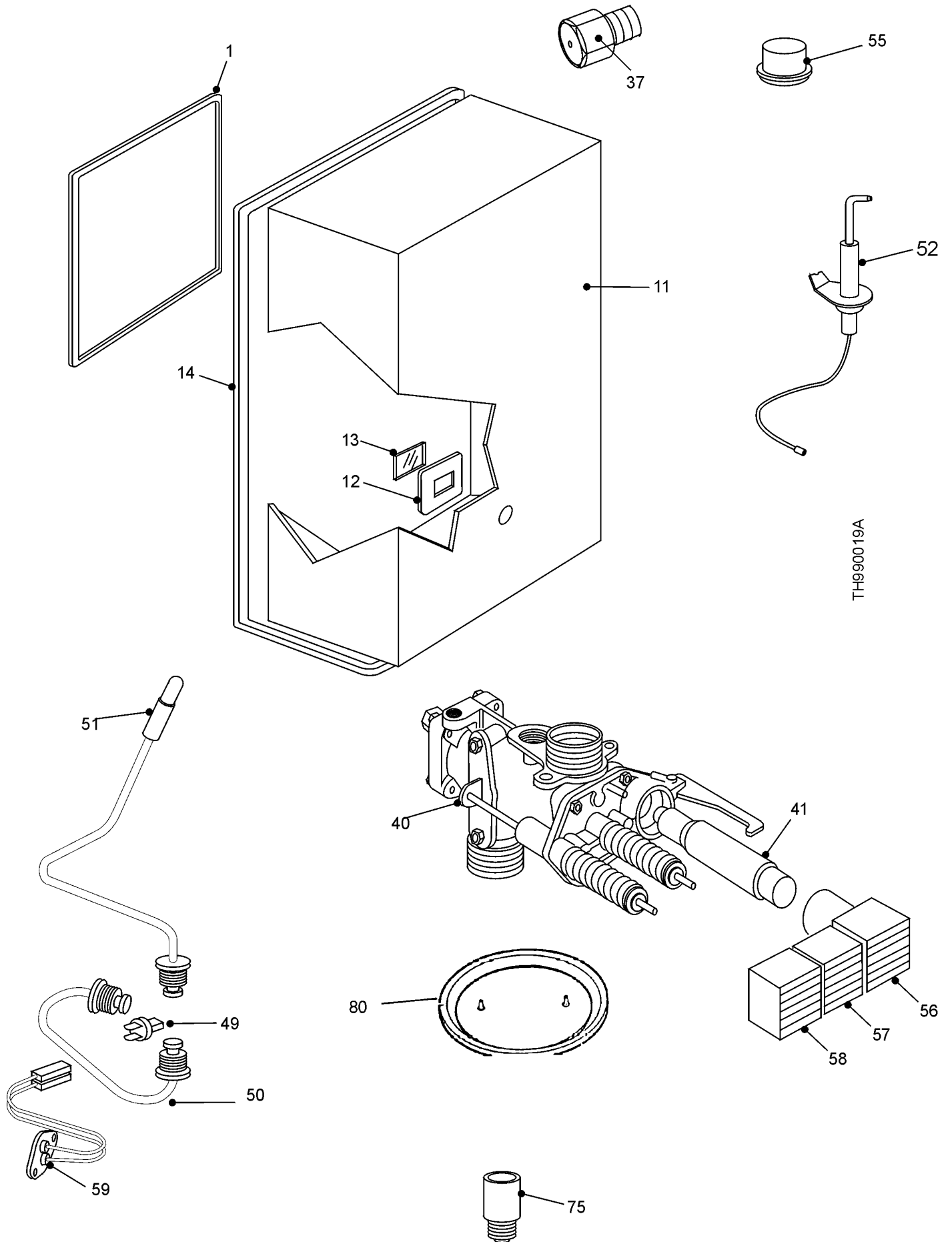

SHORT SPARE PARTS LIST - Page 22

Key No.	G.C. Part No.	Description.	No. Off.	Makers Part No.
1	284 957	Seal Pack - Chassis to Flue Terminal	1	31/12299
11	285 907	Case Assembly	1	10/17543
14	285 910	Case Seal - Self Adhesive Rubber	1	10/17501
12	285 908	Viewing Aperture Seal	1	10/17499
13	285 909	Viewing Aperture Glass	1	10/17500
37	285513	Injector N.G. 1.2mm	14	19/12196
40	285 678	Flame Safety Device Assembly	1	10/13477
51	285 930	Thermocouple - Special	1	10/17461
50	285 929	Thermocouple Connection - Special	1	10/17790
49	397 688	Interrupter Insert	1	10/13846
52	285 931	Electrode Assembly	1	10/17493
55	285 679	Pilot Injector - Special	1	19/12690
41	393 492	Piezo Unit- RV 1174	1	10/11935
56	285934	Igniter 'IGN' Button	1	10/17507
57	285 935	Starter 'ON' Button Assembly	1	10/17540
58	285 936	Stop 'OFF' Button Assembly	1	10/17541
80	285 955	Diaphragm Assembly	1	10/17572
59	285 937	Energy Cut-Off Device Assembly - includes grommets	1	10/17792
75	285 956	Pressure Relief Valve Assembly	1	10/17865

Back Page