

Installation Instructions - Flue Systems

Powermax HE
85, 115 & 150 Litre
Condensing Boilers with
Integrated Hot Water Storage

These instructions cover the installation of the following kits and their options:

- Concentric Flue - Horizontal Terminal, Page 5
- Twin Flue - Vertical Terminal, Page 10
- Twin Flue - Pitched Roof Terminal, Page 12
- Twin Flue - Mini Horizontal Terminal, Page 13

Contents

- General Flue Guidance, Pages 1 to 4
- Concentric Kit, Page 4
- Twin Flue Guidance, Pages 6 to 7
- Twin Flue Kits, Pages 8 & 9

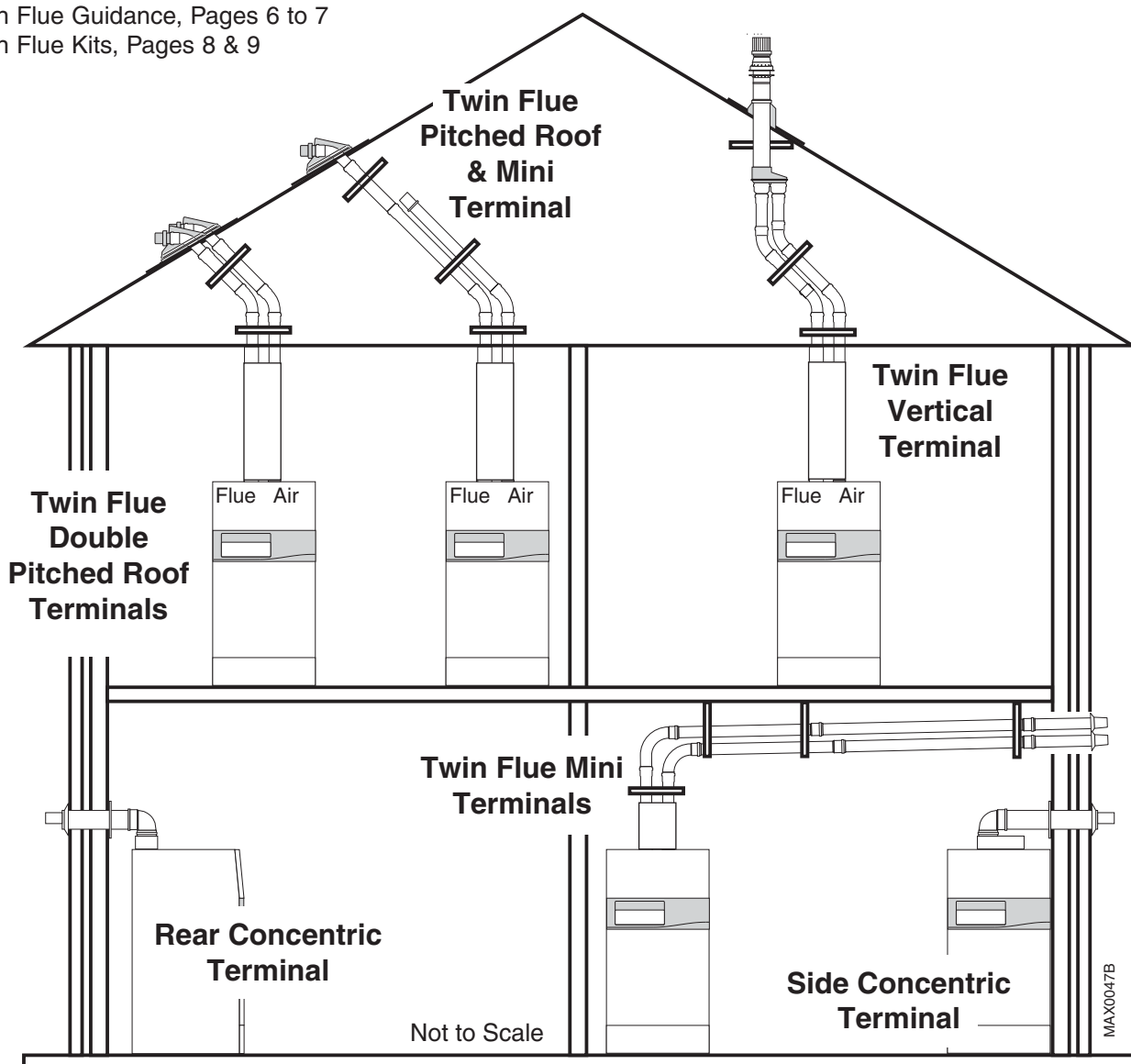

Fig. 1

Flueing

This is a “room sealed” condensing appliance. Flue systems are supplied in kits, or components can be ordered individually from Potterton. Only Powermax flue components (which are designed for condensing operation) can be used.

Flue Systems

All appliances are supplied to accept the Powermax 60 mm dia. twin flue system, however several flue system options are available.

Each system is room sealed and offers a choice of flue type and termination method, see Fig. 2.

- Concentric balanced flue with horizontal terminal
- Twin flue with vertical terminal *
- Twin flue with pitched roof terminal *
- Twin flue with horizontal mini terminal

Flue kits are available for each of the above options and each kit contains all of the components needed for connection to the appliance and terminal. Flue extension lengths and bends should be purchased separately, as required.

* These terminals must be ordered/specified separately.

Flue Protection

When using an extended flue system it is essential to fit protective ducting (such as that supplied in the extended flue kits) in order to prevent direct contact with the hot flue pipe, See Page 7.

General Requirements for Horizontal Flue Terminations

Detailed recommendations for flueing are given in BS5440: Part 1. The following notes give general guidance. The horizontal balanced flue terminal must be installed so that it is exposed to external air, preferably on a clear expanse of wall. Acceptable positions are indicated in Fig. 3. Avoid positions where the terminal is adjacent to projections; particularly immediately under a balcony, inside a re-entrant position, or immediately adjacent to a drain pipe. If the appliance is fitted under a ventilator or opening window, the terminal must be at least 300 mm from any part of the window or ventilator and in accordance with BS5440: Part 1.

The flue pipe must not be closer than 25 mm to combustible material. Additional clearance must be provided when passing the flue through timber walls. Advice on gas installations in timber framed buildings is contained in IGE technical publication IGE/UP/7 available from the Institution of Gas Engineers, 21 Portland Place, London W1N 3AF.

Guidance notes for Flue Installation

Read these Installation Instructions before installing the boiler. Before starting an installation, check that the correct flue kit has been supplied with the boiler.

Detailed recommendations for flue installations are given in BS 5440:1: 2000. The following notes are for general guidance only.

- a) The flue system must be constructed using only Powermax approved components.
- b) It is important that the position of the terminal allows free passage of air across it at all times.
- c) It is **ESSENTIAL TO ENSURE** that products of combustion discharging from the terminal cannot re-enter the building, or any other adjacent building, through ventilators, windows, doors, other sources of natural air infiltration, or forced ventilation / air conditioning.
- d) The minimum acceptable dimensions from the flue terminal to obstructions and ventilation openings are specified in Figs. 3 & 4 on Page 4 of these instructions.
- e) If the flue terminal discharges into a pathway or passageway check that combustion products will not cause nuisance and that the terminal will not obstruct the passageway.
- f) Where terminals are fitted within 850 mm of a plastic or painted gutter, or 450 mm of painted eaves, an aluminium shield at least 750 mm long must be fitted to the underside of the plastic or painted surface.
- g) Where installation will be in an unusual location, special procedures may be necessary. BS 6798 gives detailed guidance on this aspect.
- h) As the Powermax is a condensing appliance the flue duct must have a generous fall back to the boiler of nominally 2°.
- j) The efficient condensing operation of the Powermax HE will naturally give rise to condensation in the flue gases and **plumbing will occur in all but the most favourable atmospheric conditions**. Some condensate may also be discharged from the terminal. The terminal must, therefore, be **sited to avoid nuisance from either phenomenon**.
- k) Where the lowest part of the terminal is less than 2 m above the level of any ground, balcony, flat roof or place to which people have access, the terminal must be protected by a guard of durable material. A Terminal Guard, Part No. P210 is available from Potterton. The guard requires a flat wall surface of approximately 330 mm diameter, concentric with the terminal assembly.

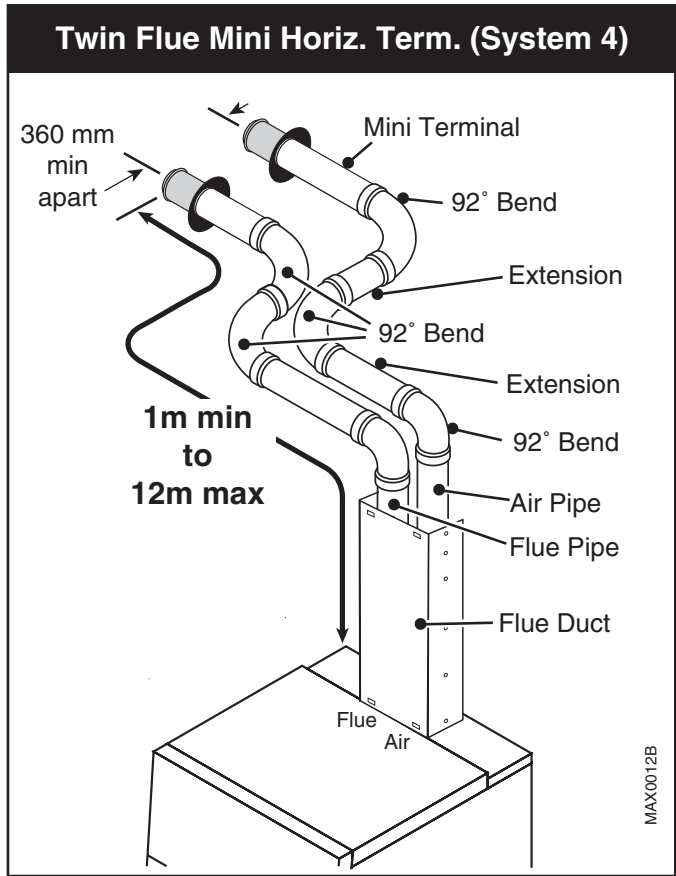
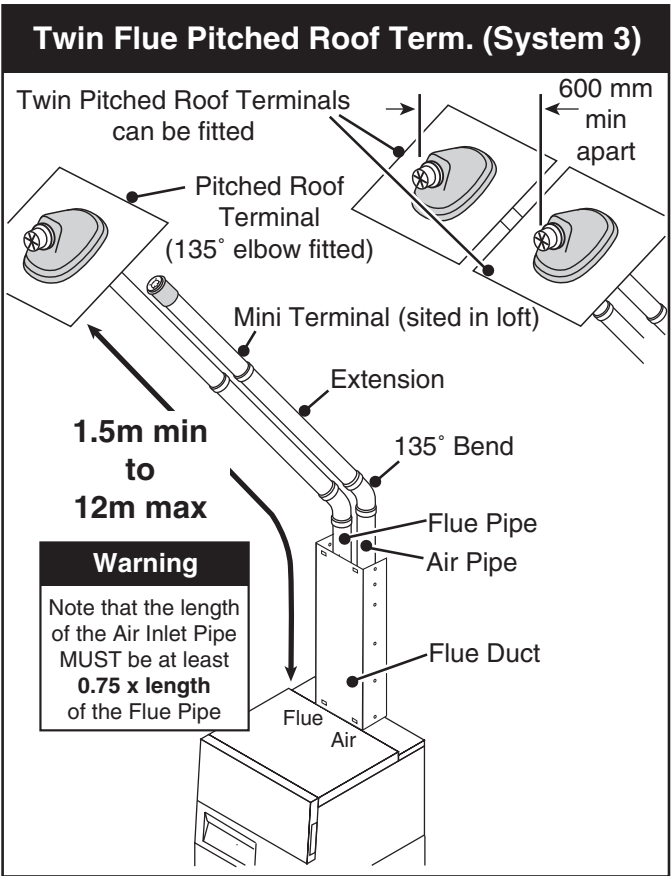
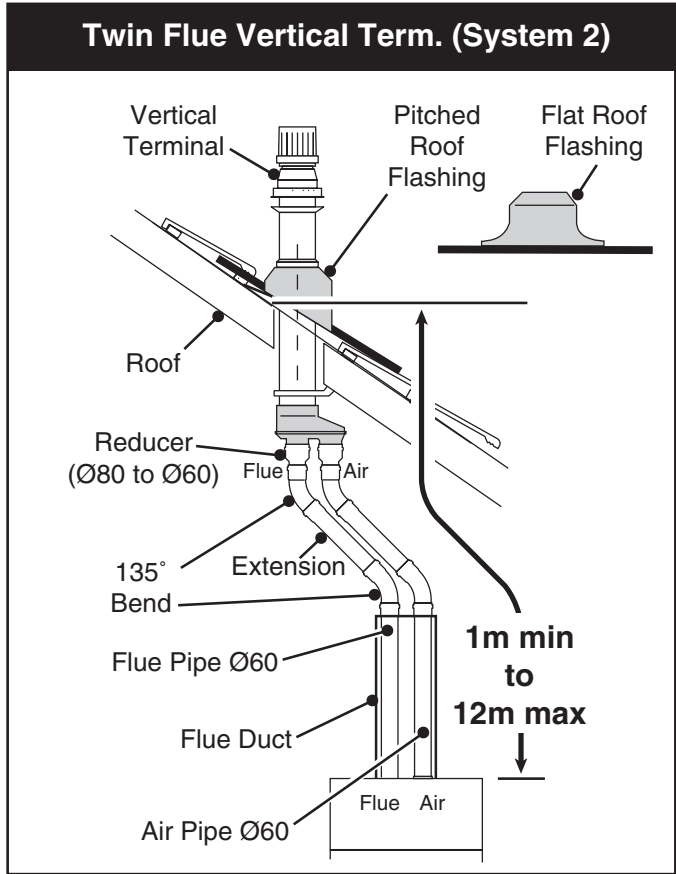
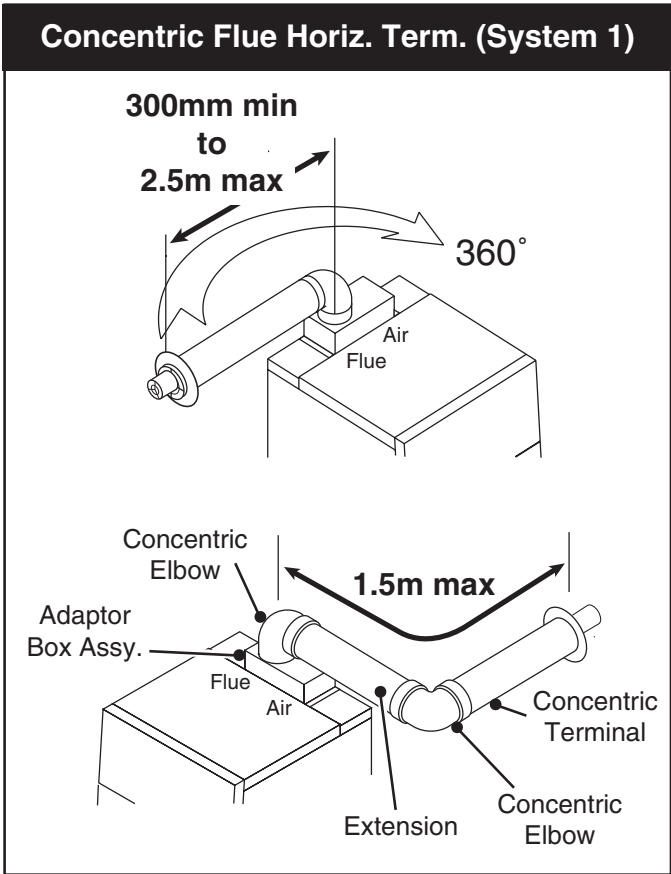

MAX0012B

Fig. 2

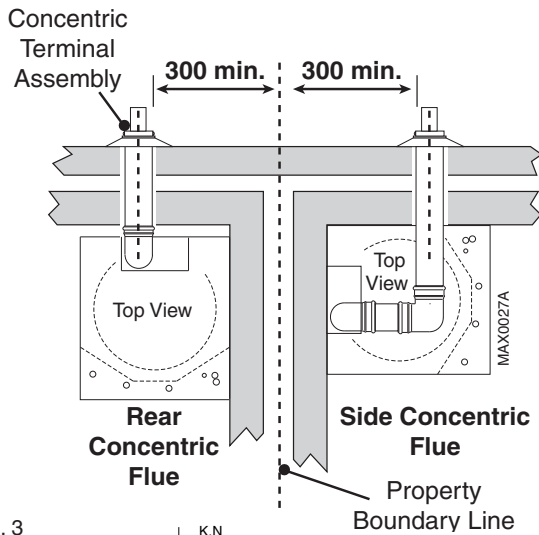
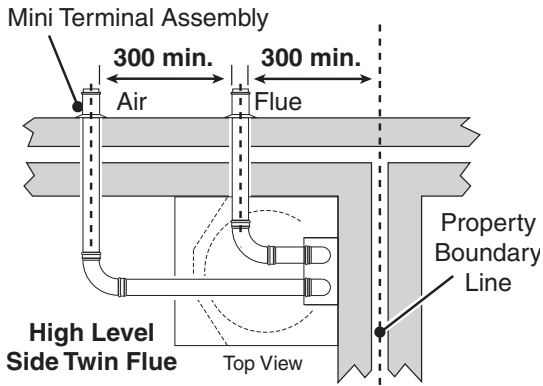

Horizontal Terminal Position with Minimum Distance (mm)

Fanned Draught Balanced Flue

A	Directly below an opening, air brick, opening window etc.	300
B	Above an opening, air brick, opening window, etc.	300
C	Horizontally to an opening, air brick, opening window etc.	300
D	Below a gutter, or sanitary pipework	75
E	Below the eaves	200
F	Below a balcony or carport roof	200
G	Above ground, roof or balcony level	300
H	From vertical drain/soil pipe work	150
J	From an internal or external corner	300
K	From a surface facing a terminal	600
L	Vertically from a terminal on the same wall	1500
M	Horizontally from a terminal on the same wall	300
N	From a terminal facing the terminal	1200
P	From an opening in a carport (e.g. door, windows) into the building	1200
Q	From adjacent wall to flue (vertical only)	210
R	From internal corner to flue (vertical only)	230
S	Below eaves or balcony (vertical only)	600

Note: The distance from a fanned draught appliance terminal installed parallel to a boundary may not be less than 300 mm in accordance with the diagram opposite.

Fig. 3

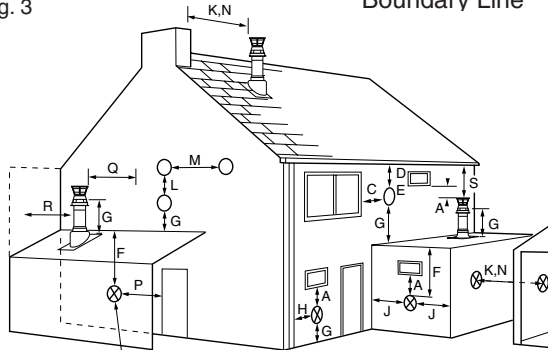

Position for Rear Flue Hole

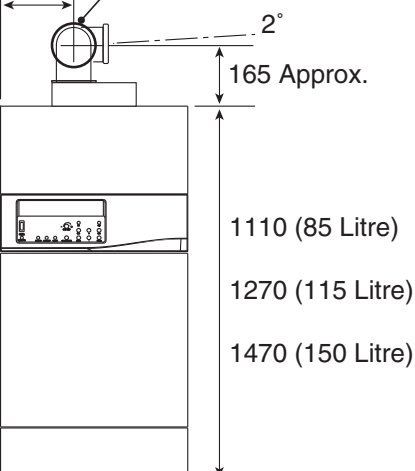
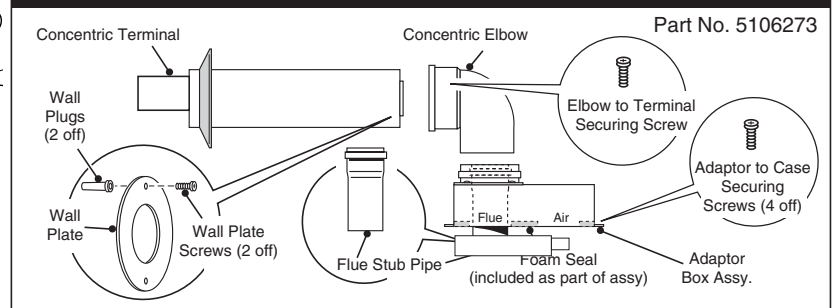

Fig. 4

Concentric Horizontal Terminal Flue Kit



Options for Concentric Flue

1.0 m Concentric Extension

Part No. 5106272

0.5 m Concentric Extension

Part No. 5106271

0.25 m Concentric Extension

Part No. 5106270

Maximum Flue Length 2.5 m

Concentric Elbow 90°

Part No. 5106158 (1 max.)

Concentric Elbow 135°

Part No. 5107645 (2 max.)

(additional to Adaptor Box Elbow)

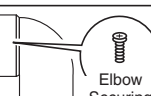

Terminal Guard

Part No. 5106217

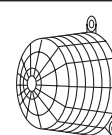

MAX0028B

Concentric Balanced Flue System

The concentric balanced flue system is recommended for use with appliances sited near an outside wall. The Concentric Flue Kit (Part No. 5106273) includes all the components necessary for connection to the appliance and termination on an outside wall and is suitable for a wall thickness from 200 mm to 450 mm.

A maximum flue length of up to 2.5 m may be used if required and the flue system may also include either 1 x 90° (p/n 5106158) or 2 x 135° bends (p/n 5107645) in addition to standard appliance elbow.

All additional flue lengths, flue bends and other kits should be purchased separately as required. See Pages 8 and 9.

Read the 'Guidance Notes' on Page 2 in conjunction with the following notes prior to installation.

- Remove protective strip from gasket underneath the twin concentric adaptor and carefully locate adaptor on top of the appliance. Ensure a good seal over the flue and air connections before securely fixing with the four M4 screws provided.
- Insert stub flue pipe into flue outlet on top of boiler.
- The 90° appliance elbow can now be fitted into the adaptor and the appropriate length of flue pipe calculated by measuring between the outside wall face and the appliance bend allowing 45 mm to 55 mm to engage into the bend.
- Fit outer wall seal to terminal and engage inner wall plate as shown.
- All flue components contain rubber lip seals to ensure both ease of assembly and excellent sealing. **Refer to Page 6 before cutting.**

Note: Powermax HE is a condensing boiler and the flue system must have a generous fall back to the boiler of nominally 2°.

Dimensions in mm

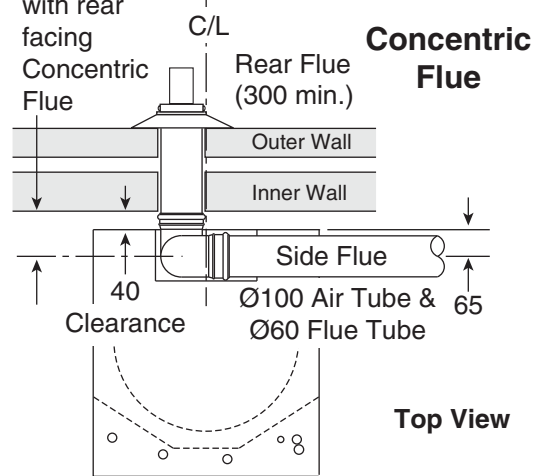

Top View

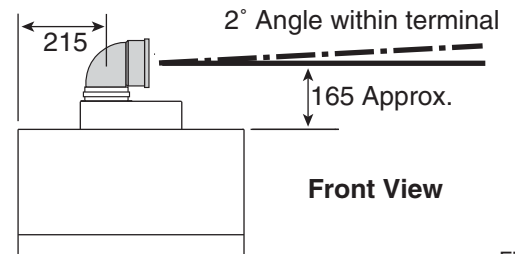

Front View

Fig. 5

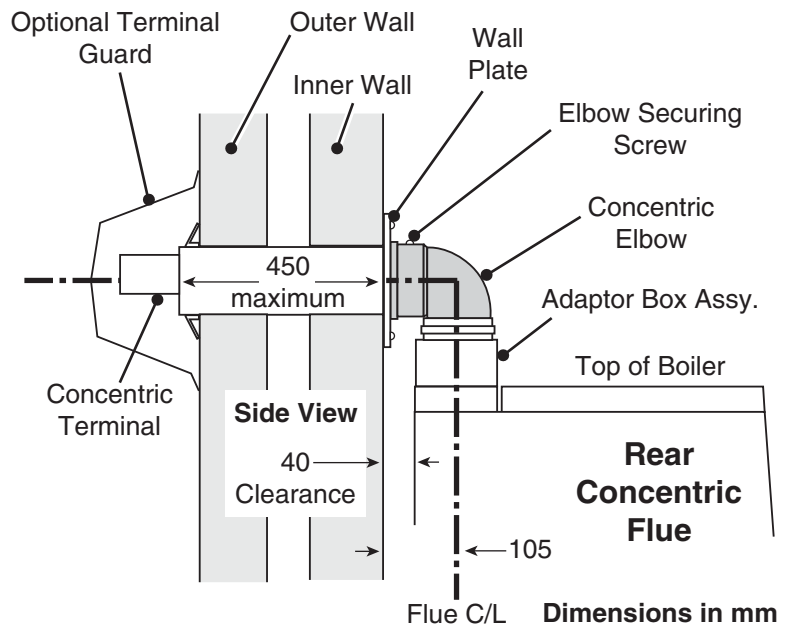

Side View

Rear Concentric Flue

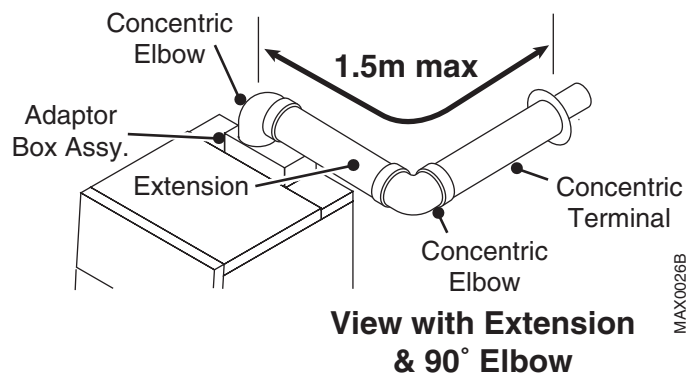

MAX0026B

Fig. 6

Guidance Notes on Twin Flue Installations

Twin Flue Pitched Roof Terminal

The air pipe **MUST NOT BE LESS** than $\frac{3}{4}$ of the length of the flue pipe. See Fig. 7.

Cutting Extensions

All flue components contain rubber lip seals to ensure both ease of assembly and excellent sealing.

Care must therefore be taken to **remove all burrs and sharp edges** from pipes which have been cut to non-standard lengths.

Expansion Allowance

When cutting and fitting flue pipes on extended flue systems, allow approx. 5 mm clearance at the bottom of each joint - see Fig. 7.

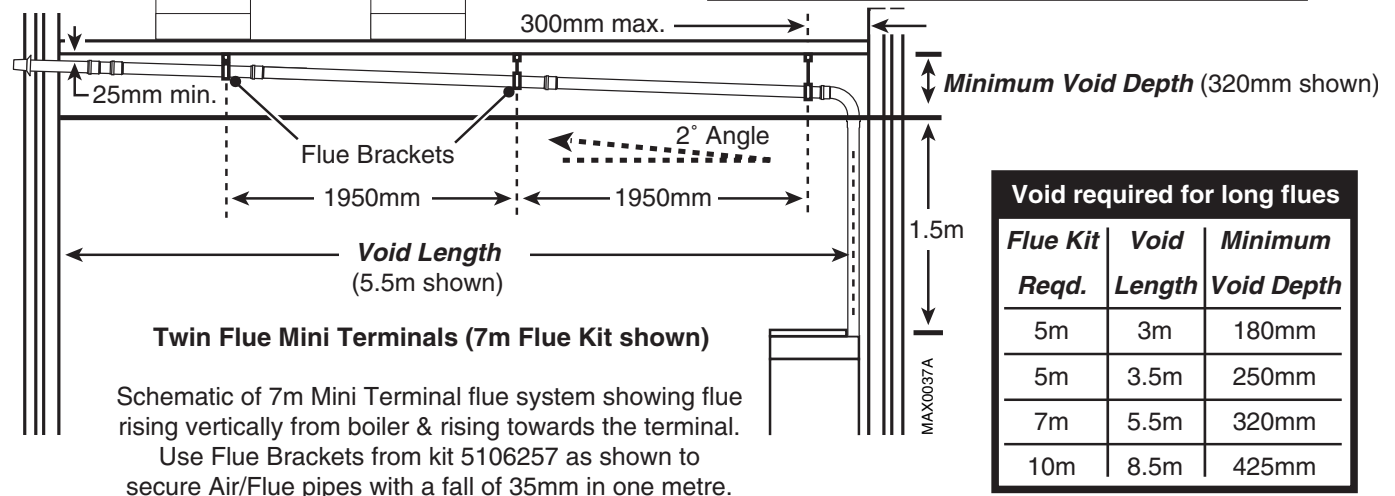
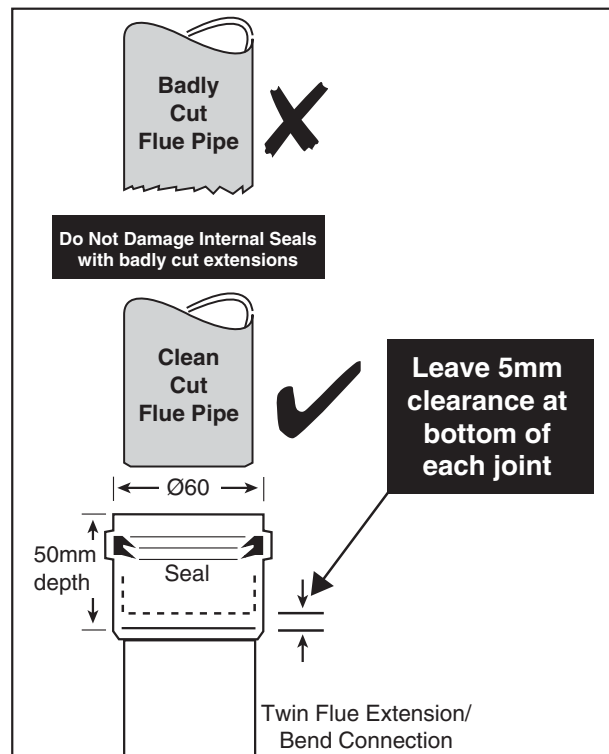
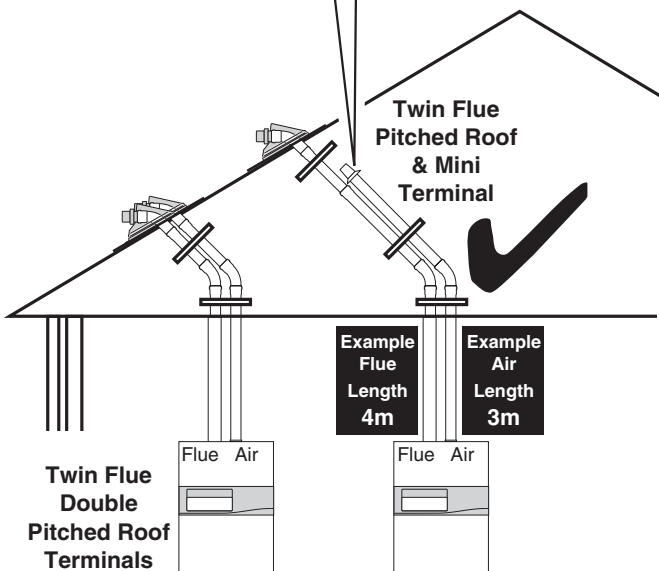
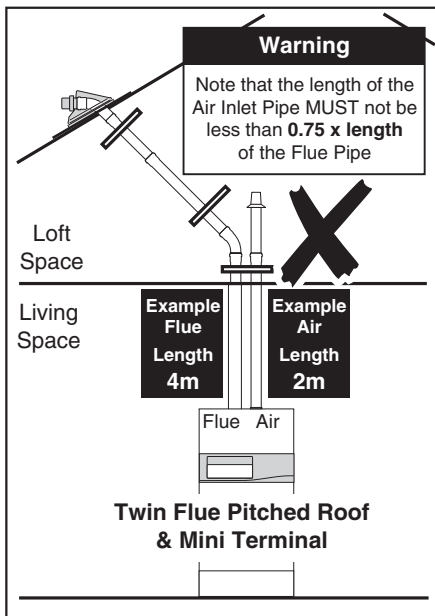

Void required for long flues		
Flue Kit Reqd.	Void Length	Minimum Void Depth
5m	3m	180mm
5m	3.5m	250mm
7m	5.5m	320mm
10m	8.5m	425mm

Fig. 7

Flue Duct

This kit covers pipe lengths from 0.5 m to 1.45 m

1. Measure length of flue/air pipes to be covered. Set the short and long covers to the required length and secure through the relevant holes using four of the self tapping screws provided.
2. Attach the pipe clip brackets to the top and bottom of the covers using the remaining four self tapping screws provided.
3. Push the assembly onto the pipes until the clips locate around the pipes.

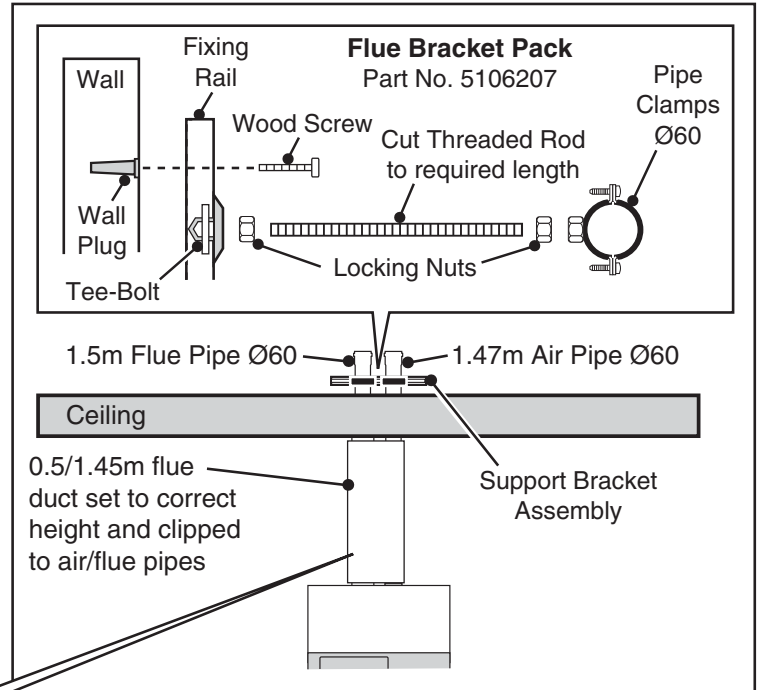
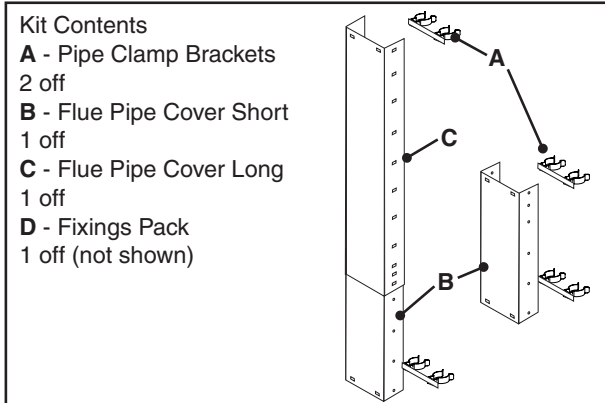

Air/Flue Pipe Support

It is recommended that the air/flue pipes should be clipped or otherwise supported at not more than 2 m intervals.

Ensure that vertical lengths of flue are adequately supported so that the joints cannot "creep" in use.

Ensure that air/flue pipes are clamped within 300 mm of every bend. Obtain extra Flue Bracket Packs (Part No. 5106207) as required.

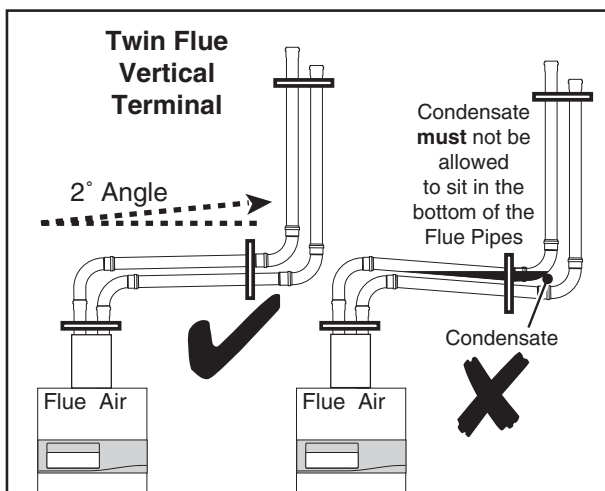
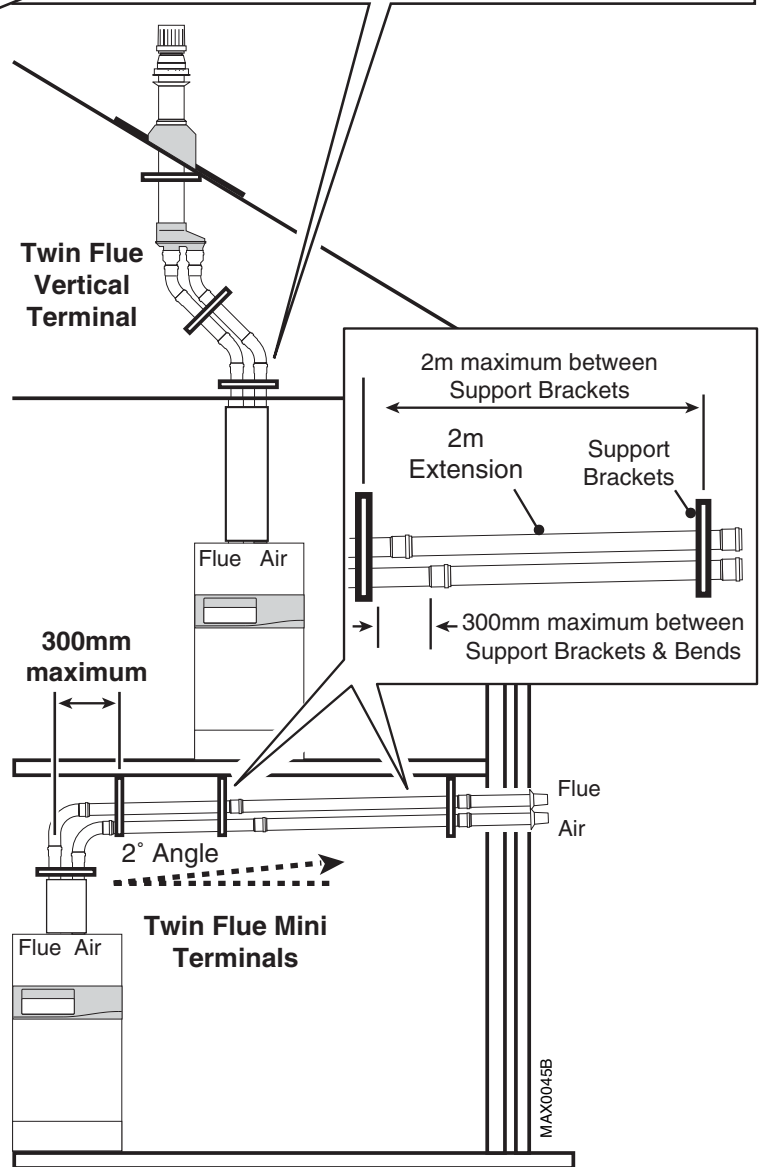
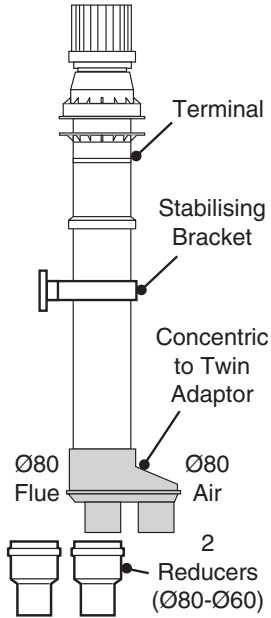

Fig. 8

Twin Flue Vertical Terminal Kit

Vertical Concentric Terminal

Part No.5106213



Pitched Roof Flashing

Part No.

15-25° = P231

25-45° = P232

35-55° = P233

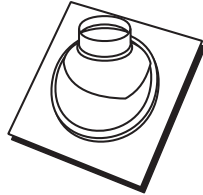

Flat Roof Flashing

Part No.
P236

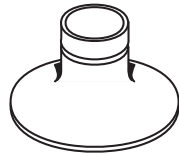

2.5m Twin Flue Pipe Kit (for Vertical Terminal)

Part No.5106260

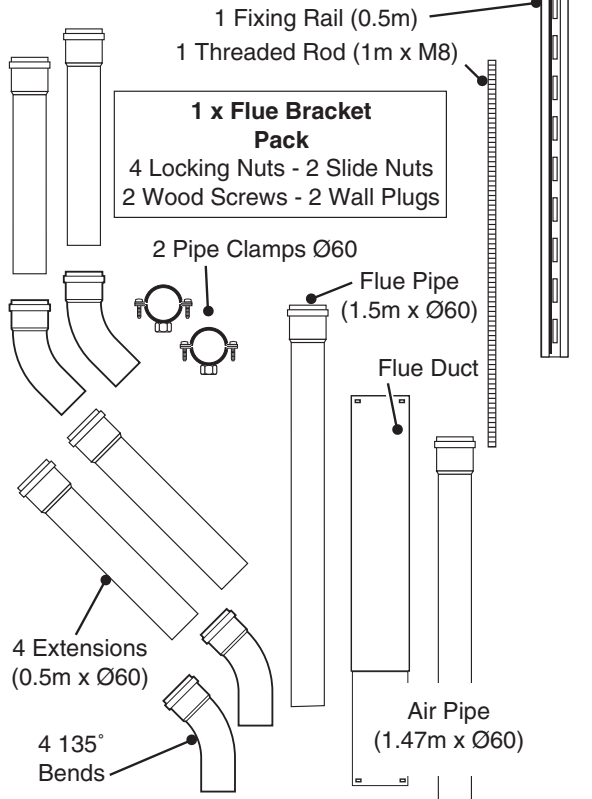

Twin Flue Pitched Roof Kit

Pitched Roof Terminal (25° - 45°)

Part No.5106164

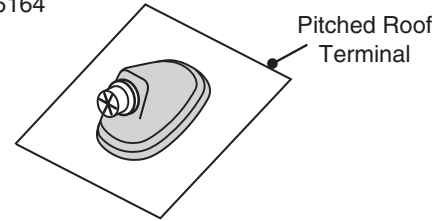

4.5m Twin Flue Pipe Kit (for Pitched Roof Term)

Part No.5106259

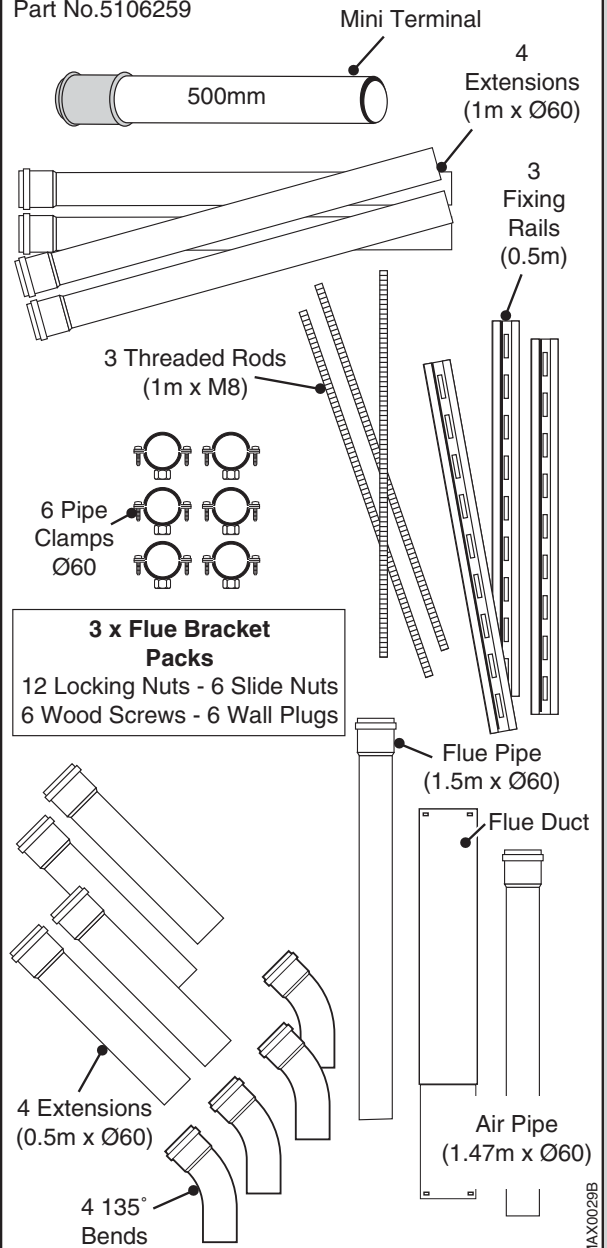
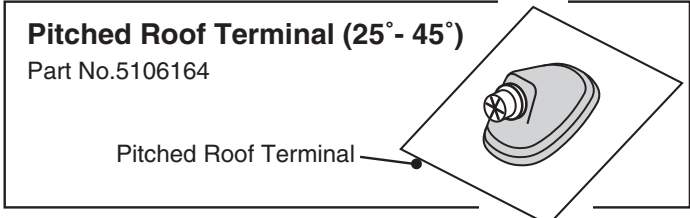
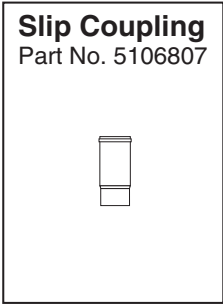
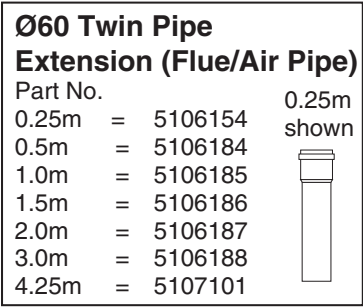
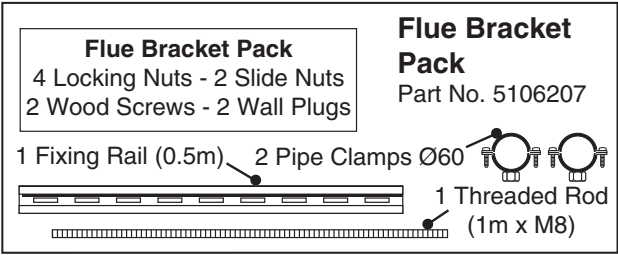
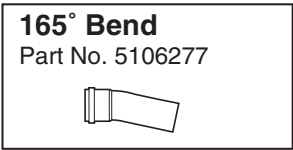
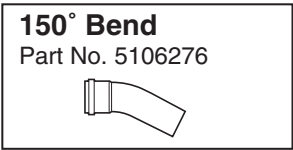
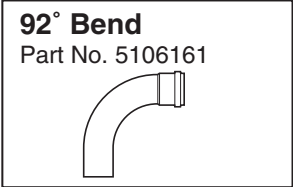
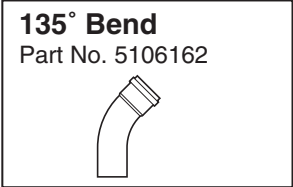

Fig. 9



Twin Flue Options



Twin Flue Mini Terminal Kits

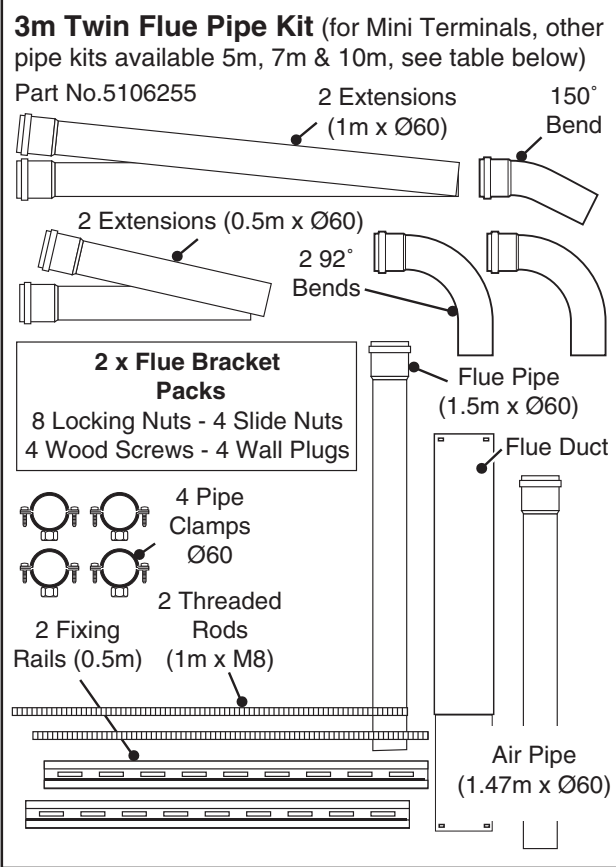
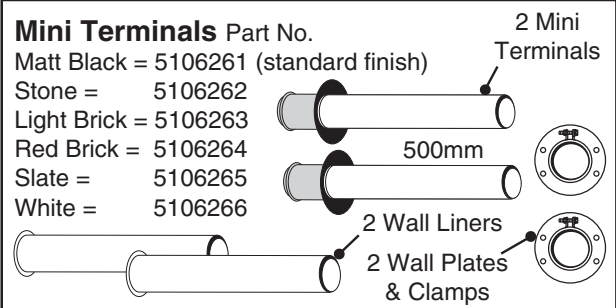

Twin Flue Pipe Kits (for Mini Terminals)	3m	5m	7m	10m
Part Number (3m illustrated above)	5106255	5106256	5106257	5106258
Air/flue pipe 3.0m	0	0	0	0
Air/flue pipe 2.0m	0	2	4	6
Air/flue pipe 1.5m	1	1	1	1
Air pipe 1.47m	1	1	1	1
Flue Duct Telescopic 0.5/1.45m	1	1	1	1
Air/flue pipe 1.0m	2	2	2	4
Air/flue pipe 0.5m	2	2	2	2
92° Bend	2	4	2	2
150° Bend	1	1	1	0
Flue Bracket Pack	2	3	3	5
M8 x 1m Thread rod	2	3	3	5
Installation Instructions	1	1	1	1

MAX0030B

Fig. 10

Vertical Concentric Terminal

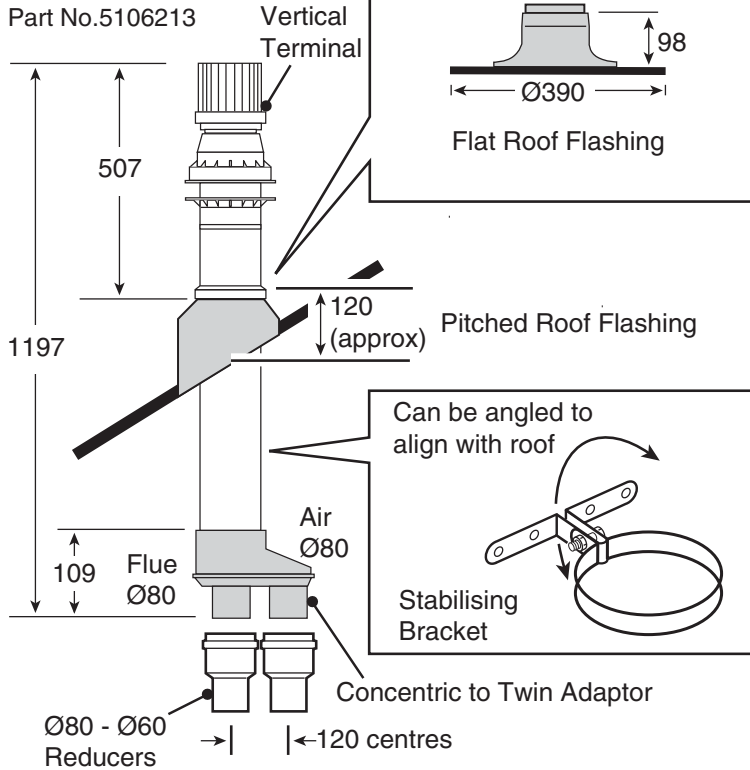

Fig. 11

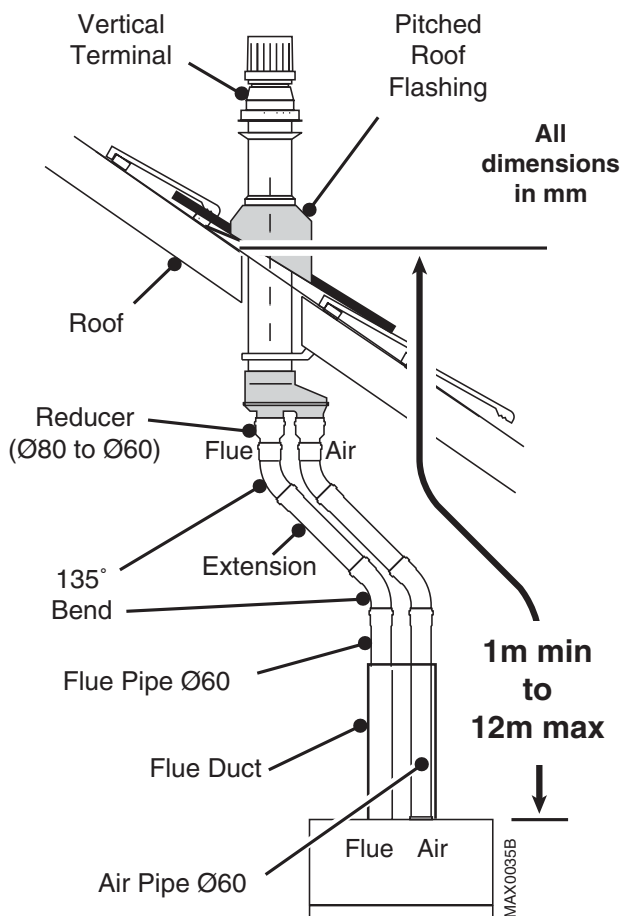

Fig. 12

Twin Flue with Vertical Balanced Flue Terminal

Used in conjunction with the standard 60 mm twin pipe system the Powermax Vertical system offers an unobtrusive balanced flue terminal as an easy to fit option for both pitched and flat roofs.

The twin flue system allows greater flexibility when siting the appliance. It offers up to 12 m of flue pipe and 12 m of air pipe, which must be reduced to accommodate a number of bends for more difficult applications. The minimum length is 1 m.

The separately supplied Vertical Terminal Kit (Part No. 5106213) provides a combined air intake and combustion gas outlet in a concentric arrangement. Below the roof the terminal changes into a twin pipe system.

Separate roof flashing units should be ordered for pitched or flat roofs. Roof pitches from 15° to 55° are catered for by selecting one of three roof flashing units.

- P231 for pitches 15° to 25°
- P232 for pitches 25° to 45°
- P233 for pitches 35° to 55°
- P236 for flat roofs

To connect the Powermax HE to the vertical terminal, a twin flue pipe kit (Part No. 5106260) is required. This contains a range of extension air/flue pipes and bends to enable the terminal to be sited up to 2.5 m from the boiler. The maximum overall length of the complete flue system must not exceed the limits shown in Fig. 2, Page 3.

All additional flue lengths, flue bends and other kits should be purchased separately as required. See Pages 8 and 9.

Read the 'Guidance Notes' on Page 2 in conjunction with the following notes prior to installation.

- a. The Powermax is a condensing appliance and the flue system must have a generous fall back to the appliance (nominally 2°) and be adequately supported. This will ensure the correct trouble free disposal of condensate produced in the flue during normal operation.
- b. All flue components contain rubber lip seals to ensure both ease of assembly and excellent sealing. **Refer to Page 6 before cutting.**

Note: Damage to the seals could result in condensate/flue products leakage from the flue system.

Note: Due to the high efficiency and reduced flue gas temperature of the Powermax HE, little or no buoyancy is generated in a vertical length of the 60 mm Ø flue pipe and installations should therefore be designed with this in mind.

Fixing Flat Roof Flashing

Installation of the flat roof flashing unit must be carried out by a competent flat roofing contractor. The following notes are for the contractor's guidance. Avoid locating the flat roof flashing in a position where standing water is likely to accumulate.

For built up felt roofs, see Fig. 13.

1. Cut 180 mm diameter service opening through roof construction and first layer of felt.
2. Bed flange of unit on to felt with bitumen.
3. Dress top layer(s) of felt over flange of unit.
4. Star cut a hole in the top-most layer and finish by detailing a 100 mm high felt collar around upstand.
5. Apply a butyl or mastic sealant around the spigot on the flashing unit and carefully lower the terminal into position, ensuring that the spigot seats securely inside the terminal rim.
6. From inside the building fit the 131 mm diameter pipe support bracket around the projecting flue pipe and screw flanges to support timber or structure. Ensure flue terminal is positively secured and vertical.

For Asphalt Roofs, see Fig. 14.

1. Cut 180 mm diameter service opening through roof construction and sheathing felt and firmly locate the flashing unit in position over it.
2. Dress asphalt over aluminium flange and up neck offset of flashing unit ensuring it does not move from location.
3. Apply a butyl or mastic sealant around the spigot on the flashing unit and carefully lower the terminal into position, ensuring that the spigot seats securely inside the terminal rim.
4. From inside the building fit the 131 mm diameter pipe stabilising bracket around the projecting flue pipe and screw flanges to supporting timber or structure. Ensure flue terminal is vertical and positively secured.

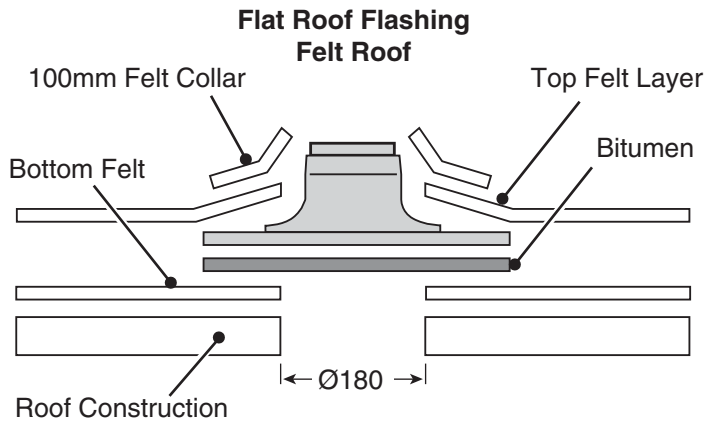

Fig. 13

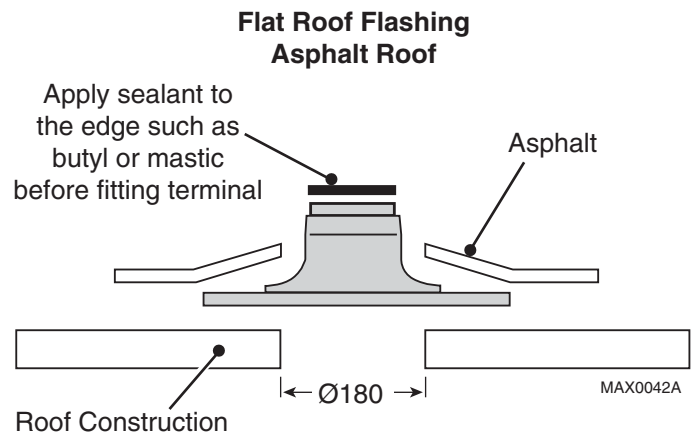

Fig. 14

Twin Flue with Pitched Roof Terminal

Used in conjunction with the standard 60 mm diameter twin pipe flue system, the Powermax Pitched Roof Terminal (Part No. 5106164) provides an unobtrusive alternative where horizontal mini terminals are not practical. This terminal is supplied with a 0.5 m x 0.5 m universal lead slate; thus it is suitable for use with tiles and slate roofs with pitch angles of 25° to 45° (above the horizontal).

The Pitched Roof Terminal must be ordered separately. It is recommended that, where space and visual considerations permit, a second similar terminal should be used for the air supply, especially when the roof pitch is less than 30°. As an alternative, combustion air can be taken from a fully ventilated, unoccupied, roof space providing the minimum free area of the vents is no less than 234 cm². Additional requirements are that the air inlet pipe must not be less than 0.75 x length of the flue pipe and the intake must be at least 300 mm above the highest level of the ceiling insulation.

The Pipework Kit (Part No. 5106259) for the Pitched Roof Terminal is based on a nominal 4.5 m of twin flue. This allows, for example, up to 5 m of flue pipe between boiler and flue terminal; plus up to 4 m of air pipe between boiler and air terminal. The flue pipe must not exceed 12 m; in which case the air pipe must not be less than 9 m. The minimum length of flue pipe is 1.5 m and the overall length is also governed by the number of bends used - see calculation method on Page 15.

The components supplied with this kit are intended for a typical application requiring 4.0 m to 4.5 m of air inlet pipe with 2 bends plus 4.5 m to 5.0 m of flue pipe with 2 bends - See Fig. 16. Other configurations may be used but a 'horizontal' run in the flue pipe should not exceed 2 m and must not be allowed to dip, i.e. fall below the horizontal and must always rise towards the terminal. Any flue pipe accessible to occupiers of the dwelling must be covered with protective ducts.

Fixing Pitched Roof Flashing

1. Place terminal flashing in position ensuring the upwards edge of lead flashing correctly underlaps the previous course. **Note:** Additional sarking may be required - see recommendation in BRE Defect Action Sheet 10 - November 1982 - Pitched Roof Sarking Felt Underlay Watertightness.
2. Fix any secondary batten needed to support terminal and reinforce any previously cut battens.
3. Cut slates or tiles to achieve the 290 mm vertical x 220 mm horizontal opening for the upstand of the terminal. Re-tile roof and dress lead flashing over bottom course.
4. Fix support bracket so as to secure the flue pipe near the terminal.

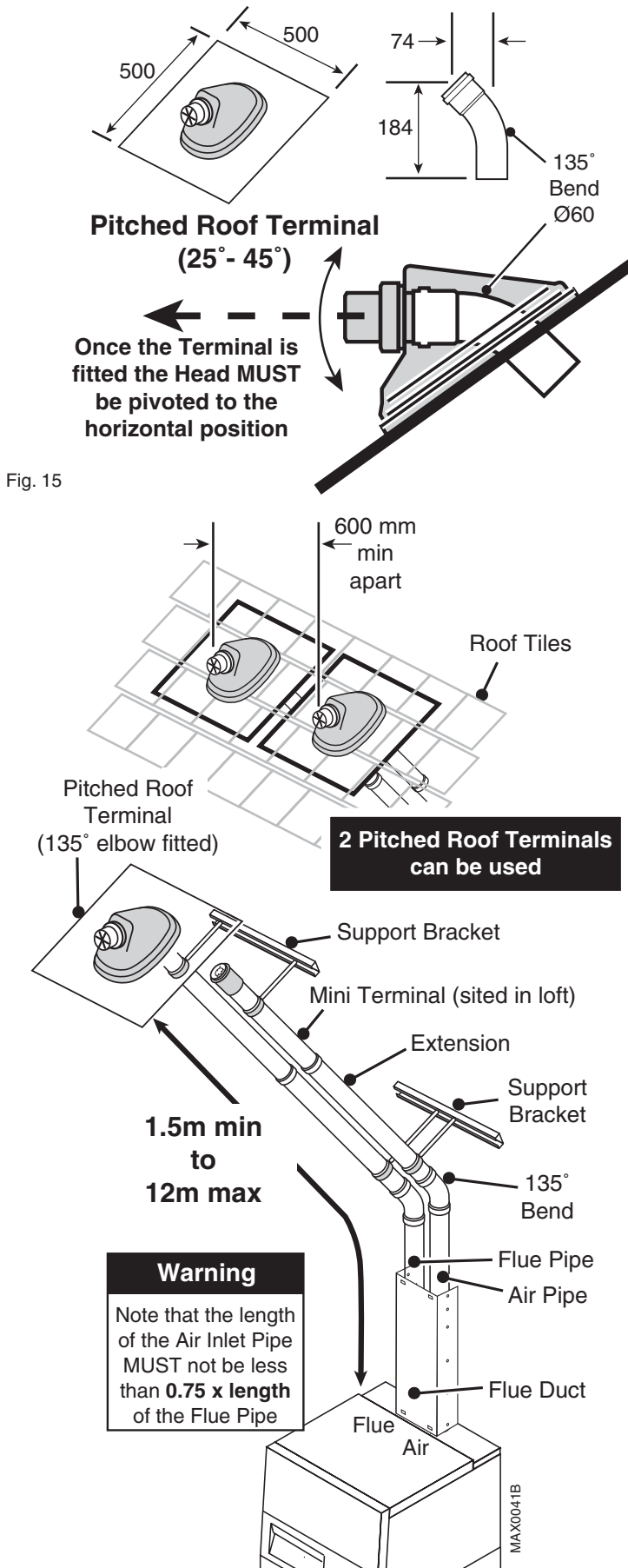

Fig. 15

Fig. 16

Twin Flue with Horizontal Mini Terminal

The Mini Terminal flue system provides an unobtrusive arrangement. Separate 60 mm diameter air inlet and flue terminal assemblies can be positioned in different locations on the same wall subject to similar wind conditions. The mini terminals are also visually less obtrusive and are available in a small range of colours to assist with the sympathetic re-furbishment of older buildings.

The twin flue system allows greater flexibility when siting the appliance. It offers up to 12 m of flue and 12 m of air pipe, which must be reduced to accommodate the number of bends for more difficult applications. Both terminals should be positioned to minimise the length of the air and flue pipes. The distance between the terminals must not be less than 360 mm and no greater than 2 m.

Maximum Flue Length: 12 m flue pipe
12 m air pipe
2 x 92° swept bends

Minimum Flue Length: 1 m flue pipe
1 m air pipe
2 x 92° swept bends

All additional flue lengths, flue bends and other kits should be purchased separately as required. See Pages 8 and 9.

Read the 'Guidance Notes' on Page 2 in conjunction with the following notes prior to installation.

- a. The Powermax HE is a condensing boiler and the flue system must have a generous fall back to the appliance (nominally 2°) and be adequately supported. This will ensure the correct trouble free disposal of condensate produced in the flue during normal operation.
- b. All flue components contain rubber lip seals to ensure both ease of assembly and excellent sealing. **Refer to Page 6 before cutting.**

Note: Damage to the seals could result in condensate/flue products leakage from the flue system.

Important: The flue terminal **MUST NOT** be sited below the air terminal. See Fig. 17.

Warning: The flue pipe becomes very hot when appliance is working. Householders should be warned not to touch exposed pipe e.g. beyond protective duct within loft. The flue pipe should be insulated or ducted if accidental contact is likely.

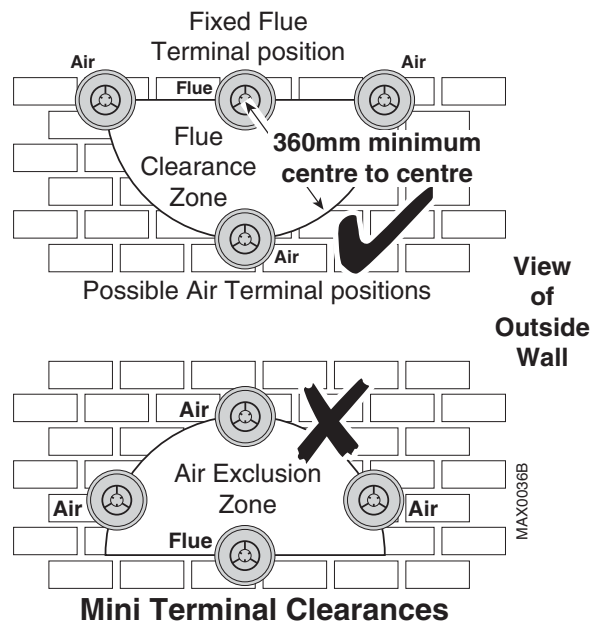
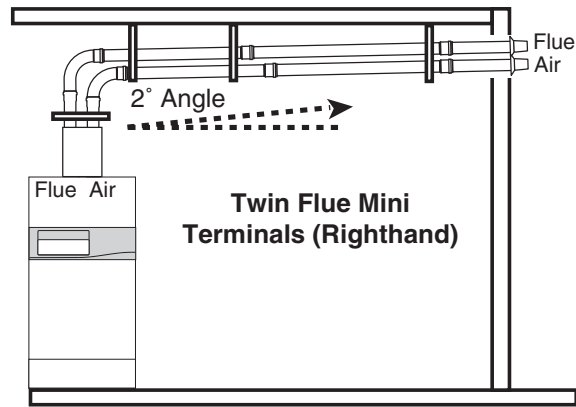

Fig. 17

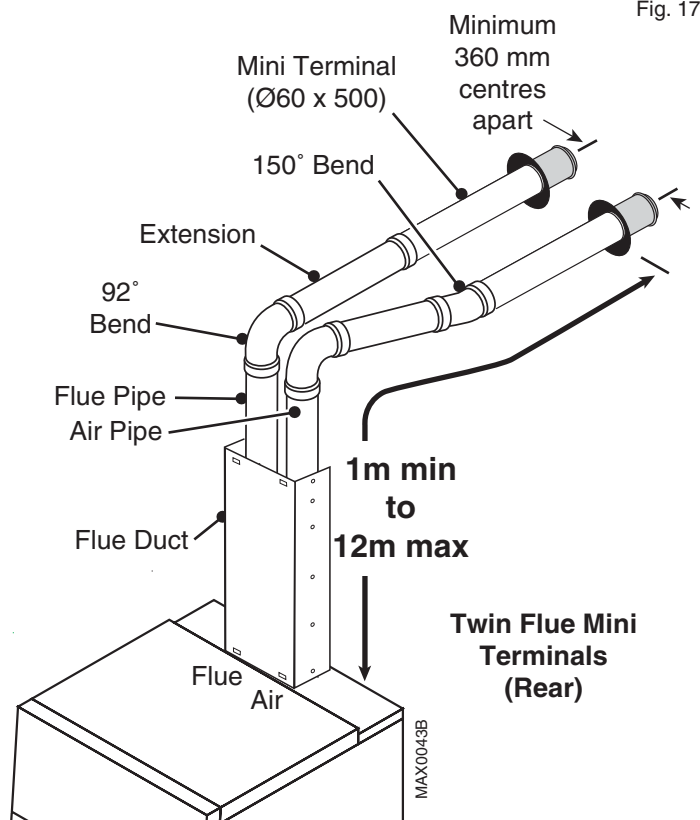

Fig. 18

Installing Mini Terminal Flues

Mark the positions of the air/flue terminals and core drill 70 mm (2¾) diameter holes. If the wall is clad with a combustible material an additional 25 mm wide area must be removed around flue liner.

With care it is possible to core drill from inside and maintain a clean, undamaged hole on the outside wall, but where damage to the outside wall occurs this must be made good to ensure a satisfactory weather seal when terminals are in position. Terminals should be inserted through the wall liner from outside to facilitate weather sealing.

- Measure the wall thickness and cut the liner to this length. Cut plain end opposite flange.
- Fit the liner through the hole making good internal and external rendering where necessary. Apply 'mastic' type sealant to the last 25 mm of the liner behind the flange (or to the outer part of the core-drilled holes) prior to fitting liner to help make a weather seal between the liner and the external leaf of the wall.
- Slide the stainless steel cone along the terminal pipe, followed by the large flexible seal as indicated in Fig. 19. Apply high temperature (red) silicone sealant to ensure the terminal is weather sealed to the liner.
- Working from outside the property, push the mini terminal through the liner until the large seal is correctly positioned against the outside wall.
- Centralise flue pipe in liner using spacer if required. Slide the internal wall plate over terminal pipe and secure to wall using the plugs and screws provided. Tighten clip to secure terminal.
Note: Make any final adjustment to the position of the external seal before tightening clip.

Assembling Air/Flue Pipes

Refer to Guidance Notes on Pages 6 & 7.

The flue pipes must be assembled with the plain end of pipe or fitting nearest the boiler and the female (socket) end furthest from the boiler. Check that a seal is fitted in every socket.

Always adjust length of pipes by cutting and de-burring plain end so that it does not damage or disturb the seal. Remove burrs from inside and outside of pipe and ensure the pipe is clean and free from oil and grease.

Any generally "horizontal" run of flue pipe **MUST NOT FORM A LOW POINT** at which condensate could accumulate.

- Measure and cut the first pair of flue pipes away from the appliance. Push pipes fully into the sockets on top of the boiler whilst also fitting the flue duct prepared as above.
- Measure and cut next pair of air/flue pipes.
- Prepare pipe support brackets as required before engaging pipes with the socket of preceding pipes or bends.
- Push pipes together as before taking care not to dislodge seals. When cutting and fitting flue pipes on extended flue systems, allow approx. 5 mm clearance at the bottom of each joint - see Fig. 7.
- Repeat above procedure to reach terminal. Ensure that air inlet and flue gas connections are correctly made and are not inadvertently reversed.
- Fix pipe supports to masonry or woodwork so that flue/air pipes are held securely in position.
- Check especially that all joints within any duct or other void are correctly engaged and sealed before fixing the ductwork.

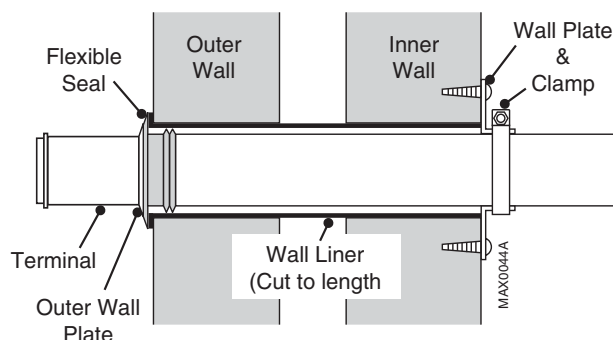

Fig. 19

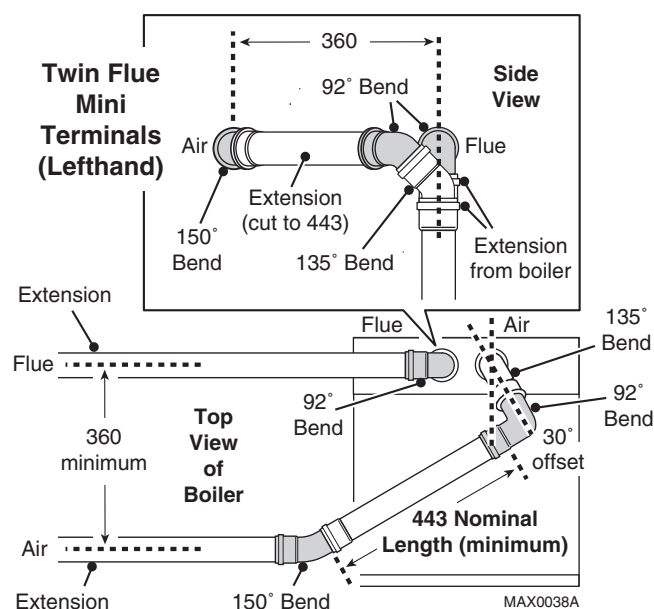

Fig. 20

Guidance on Unusual Twin Flue Installations

The following notes offer guidance regarding the relationship between the maximum flue length and the number of bends allowed in a twin flue system.

In order to simplify the calculation, the following three factors are used:-

1. Maximum System Factor

A figure of 100 is used and represents the maximum resistance that can be applied to the appliance before there is a notable reduction in its heat output.

2. Fittings Factor

This figure is calculated and represents the total resistance of all the flue / air fittings in the proposed system. e.g. bends, terminals and essential pipes such as those rising from the boiler.

3. Pipe Factor

This figure is calculated and represents the remaining resistance left for the flue / air pipe lengths in the proposed system after subtracting (2) from (1).

Note: Any flue and air pipe combination between the minimum and maximum lengths may be used in conjunction with any of the listed fittings, provided that the Maximum System Factor of 100 is not exceeded.

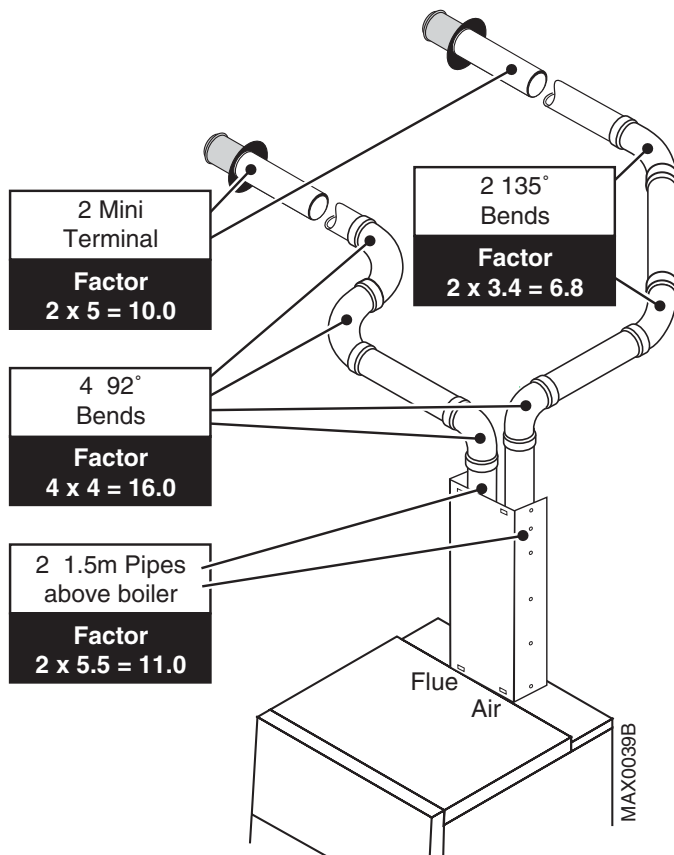

Fig. 21

Table of Flue Resistance Factors :

Component	factor
Mini Terminal (500 mm) (each)	5.0
Pitched Roof Terminal	7.0
Vertical Terminal (inc. twin pipe adaptor)	6.6
60 mm Air / Flue Pipe - 0.25 m (each)	1.2
60 mm Air / Flue Pipe - 0.5 m (each)	2.1
60 mm Air / Flue Pipe - 1.0 m (each)	3.8
60 mm Air / Flue Pipe - 1.5 m (each)	5.5
60 mm Air / Flue Pipe - 2.0 m (each)	7.2
60 mm Air / Flue Pipe - 3.0 m (each)	10.6
Bend - 92°	4.0
Bend - 135° (45° Bend)	3.4
Bend - 150° (30° Bend)	2.6
Bend - 165° (15° Bend)	1.4

Note: The above component factors are to be cumulatively subtracted from the total system factor of 100 (See Below).

Ensure that both **flue and air** pipes are counted.

Worked Example

To calculate the maximum allowable air/flue pipe length for the system shown in Fig. 21.

1. Establish the terminals, bends and essential pipework (e.g. that rising from top of boiler) and add the resistance factors obtained from the table above.

4 off 92° Bends	=	16.0 (4 x 4)
2 off 135° Bends	=	6.8 (2 x 3.4)
2 off Mini Terminals	=	10.0 (2 x 5)
Add: Essential Pipework -		
2 off 1.5 m Air/Flue Pipes	=	11.0 (2 x 5.5)
Fittings Factor	=	43.8

2. Subtract this Fittings Factor from 100
i.e 100 - 43.8 = Pipe Factor = 56.2

3. Divide this Pipe Factor by the resistance factors appropriate for the flue being designed.

e.g. 3 off 1 m Air/Flue Pipes	=	11.4
6 off 2 m Air/Flue Pipes	=	43.2
Total	=	54.6

4. Compare this total of to the available Pipe Factor:
54.6 £ 56.2 so this system is acceptable.

General Enquiries

Tel. **08706 060 780**

Sales

Tel. **08706 060 403**

Fax. **01772 695 416**

Technical *

Tel. **08706 060 955**

Service *

Tel. **08706 060 933**

Fax. **08706 060 966**

Literature Request

Tel. **08706 060 623**

Spares

Tel. **08706 000 454**

* To aid continuous improvement and staff training, calls to this line may be monitored or recorded.

All descriptions and illustrations provided in this leaflet have been carefully prepared but we reserve the right to make changes and improvements in our products which may affect the accuracy of the information contained in this leaflet. All goods are sold subject to our standard Conditions of Sale which are available on request.

BAXI POTTERTON

A Trading Division of Baxi Heating UK Ltd
Brownedge Road Bamber Bridge Preston Lancashire PR5 6SN
Website www.potterton.co.uk

A BAXI GROUP company